

Service Manual

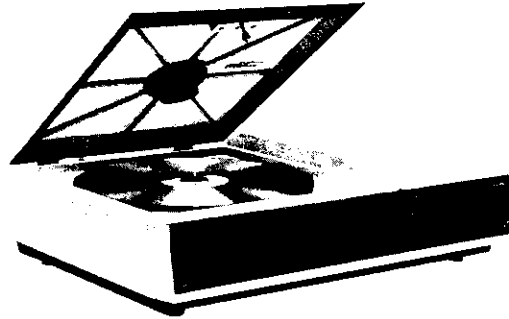

ORDER NO.
VRT-019-0

VIDEO DISC PLAYER

PR-8210-A

CONTENTS

1. SPECIFICATIONS	2	11-2 SYPS, LSPPS AND MCNB	76
2. PARTS AND CONTROLS	3	11-3 RFAM	81
3. CONNECTIONS	5	11-4 VSOP, CPCB AND PSCB	83
4. DISASSEMBLY	7	11-5 AUDX	94
5. CIRCUIT DESCRIPTIONS	9	11-6 CONT, GATB AND IOIB	98
6. SAFETY CHECK	39	11-7 KEYC AND IRAB	104
7. MECHANICAL ADJUSTMENTS	41	12. EXPLODED VIEWS AND PARTS LISTS	108
8. SLIDER ASSEMBLY AND ALIGNMENTS	45	12-1 EXTERNAL AND TOP VIEW	108
9. ELECTRICAL ADJUSTMENTS	53	12-2 BOTTOM VIEW	111
10. TROUBLE SHOOTING	68	12-3 SLIDER	114
11. SCHEMATIC DIAGRAMS, PCB PATTERNS AND PARTS LISTS	73	13. SAFETY INFORMATION	116
11-1 OVERALL	73	14. PACKING PROCESS	117

 **PIONEER***

PIONEER ELECTRONIC CORPORATION 4-1, Meguro 1-Chome, Meguro-ku, Tokyo 153, Japan
PIONEER ELECTRONICS [USA] INC. P.O. Box 1760, Long Beach, California 90801 U.S.A.
PIONEER ELECTRONIC [EUROPE] N.V. Keetberglaan 1, 2740 Beveren, Belgium
PIONEER ELECTRONICS AUSTRALIA PTY. LTD. 178-184 Boundary Road, Braeside, Victoria 3195, Australia

Printed in Japan M.E. 3 1983 10

1. SPECIFICATIONS

General

System and disc spec.
 Comply with MCA Philips specifications

*1 Maximum playing time

..... Standard play videodisc: 30 minutes/side
 Extended play videodisc: 60 minutes/side

Spindle motor revolutions

..... Standard play videodisc: 1800 RPM
 Extended play videodisc: 1800 RPM
 (inner circumference)
 to 600 RPM (outer circumference)

Laser 6328 angstrom, He-Ne 1mW

Video Characteristics

Format NTSC specification

Video output

Level ... 1Vp-p nominal, sync. negative, terminated
 Impedance 75 ohm unbalanced
 Terminal BNC type jack
 Signal to noise ratio More than 42dB

Audio Characteristics

Audio output Two channels; stereo or two
 individual channels

Level 650mV nominal (1kHz 100% mod.
 50 kilohms terminated)

Impedance Less than 2.2 kilohms unbalanced

Terminal Stereo pinjacks

Total harmonic distortion Less than 0.3%
 (1kHz 75% mod.)

Signal to noise ratio More than 70dB
 (CX encoded disc, CX NR ON, 1kHz 650mV
 output, using IHF A network)

Frequency response ... 40Hz to 20kHz (± 3 dB reference
 to 1kHz 10% mod.)

External controls

Terminal 24 Pins amphenol type

Functions

	CAV	CLV
Play (Normal play mode with sounds) ...	YES	YES
Pause (Pause mode without picture and sounds)	YES	YES
Scan forward/reverse	YES	YES

Others

Power requirements AC 120V, 60Hz
 Power consumptions 85-watts
 Dimensions 525(W) x 408(D) x 143(H) mm.
 20-21/32(W) x 15-13/16(D) x 5-5/8(H) in.
 Net weight (without package) 13.5kg (29.8 lbs)

Furnished Accessories

Audio connecting cords with pinplugs 1
 Operating instructions 1

NOTES:

Specifications and the design subject to possible modification without notice, due to improvements.

**1 Actual playback time differs for each disc.*

2. PARTS AND CONTROLS

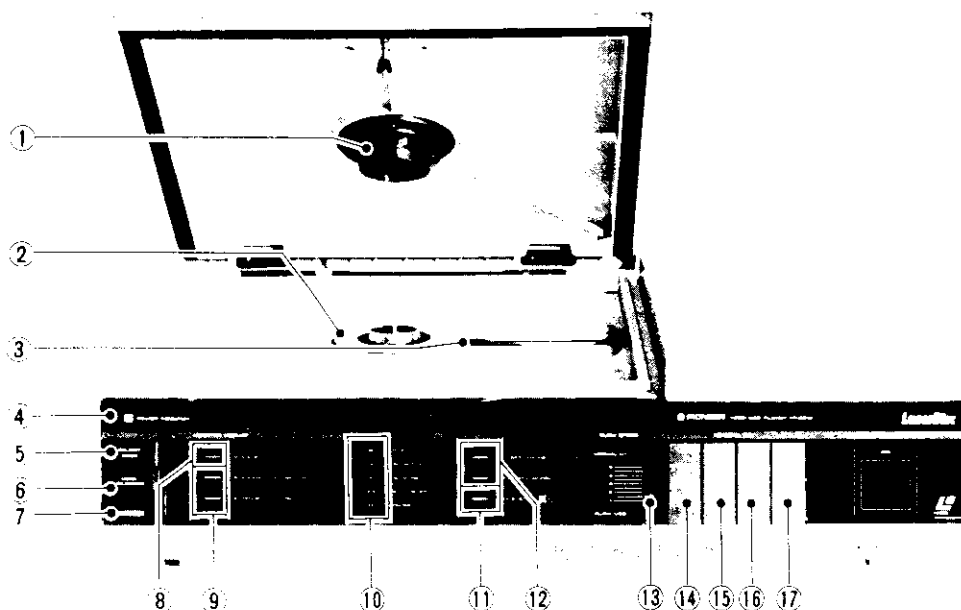

① DISC CLAMP

This holds the disc onto the turntable when the hood is closed to assure that the disc rotates smoothly.

② TURNTABLE

Place a disc on this platter so it fits over the raised center hub. The turntable is directly connected to the motor so the precise speed is maintained at all times.

③ OBJECTIVE LENS

This lens focuses the laser beam onto the disc and picks up the beam reflected back from the disc. Note that the lens surface must be kept clean in order to maintain optimum performance.

④ POWER

Press this switch to turn power on and off.

⑤ POWER INDICATOR

This lights up to show the power is on.

⑥ REJECT/OPEN

Press this key to cut off operation and to open the hood.

⑦ HOOD UNLOCKED INDICATOR

This indicator lights up when the hood is open and goes out when the hood is completely closed and locked. Note that the player can not be operated until this indicator goes out.

⑧ STAND BY INDICATOR

This indicator flashes on and off during those periods when some time is required for the player to switch to the next commanded function mode. For example: When ► marked end of the PLAY/PAUSE key is pressed after REJECT, during the return period.

⑨ DISC INDICATORS

A few moments after ► marked end of the PLAY/PAUSE key has been pressed, one of these indicators shows whether a CAV or CLV disc is being played.

⑩ PLAYBACK MODE INDICATORS

One of these indicators shows the playback mode presently selected.

⑪ CX INDICATOR

This indicator lights when the CX noise reduction system is activated.

⑫ AUDIO INDICATORS

These indicators show whether only one or both audio channels are being heard.

⑬ SLOW SPEED CONTROL

Use this control to adjust the speed of slow motion playback.

NOTE:

Slow motion playback is possible only when an external controller is being used to control the player. Slow motion playback can not be performed using the buttons on the player itself.

⑭ PLAY/PAUSE

Pressing the ► mark on the upperside of the switch starts playback or returns to normal play mode from another mode. To temporarily stop playback, press the ■ mark on the lower side of the switch. This stops the pickup, turns off both picture and sound. Pressing the ■ mark again cancels the pause mode.

⑮ SCAN

Use this key to quickly locate a particular part of the disc program or skip a part of the program.

- : press to scan quickly forward
- ◄◄ : press to scan quickly backward

⑯ AUDIO 1/L, 2/R

Use this key to turn sound off and on in the left or right channel. Pressing either end of the key turns off sound in that channel; press again to turn sound back on.

⑰ CX SYSTEM

This key turns the CX noise reduction system on and off. Turn the CX system on when playing a CX encoded disc.

3. CONNECTIONS

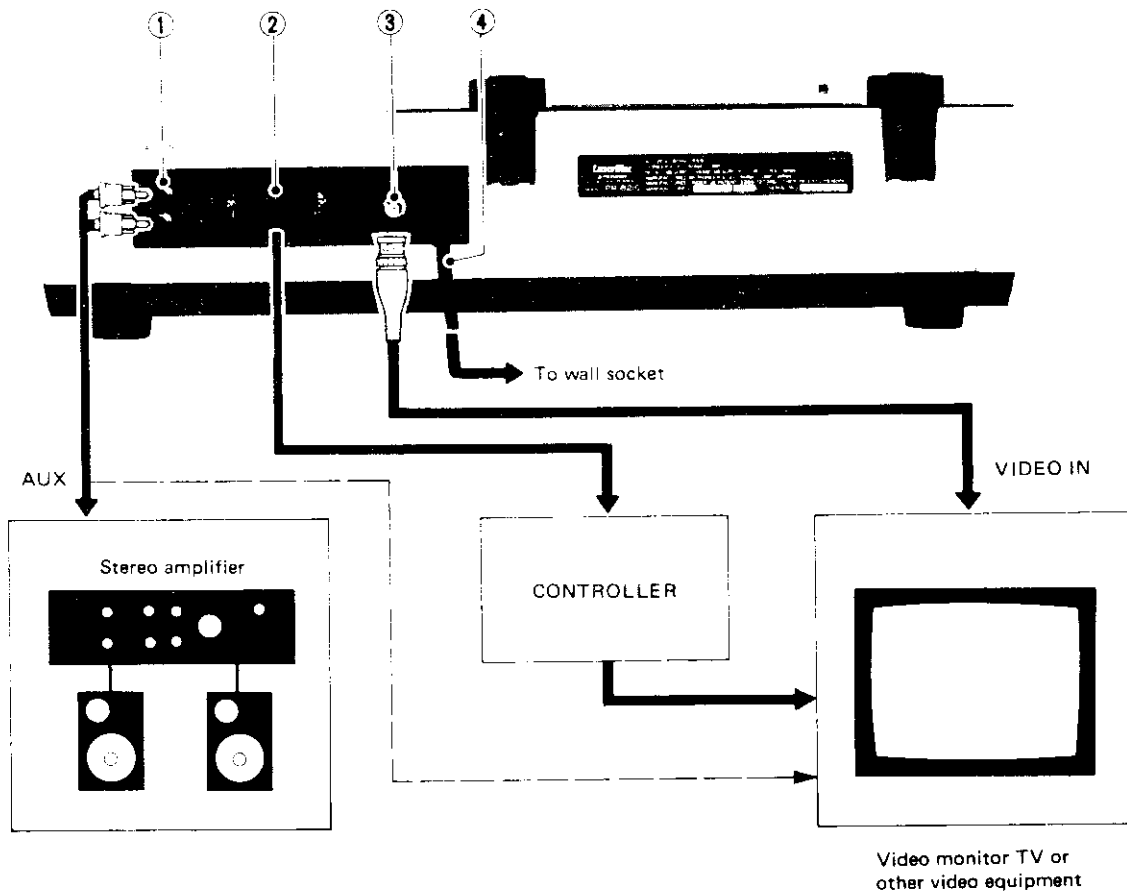

Use the coaxial cable to connect the VIDEO OUT terminal on the player to the video input terminal on the monitor TV or other video equipment (terminated video input terminal). Audio output on the player should be connected to the audio inputs of the monitor TV (or other video equipment) or to the stereo system for audio reproduction.

NOTE:

The connections diagram shows only one example of the possible ways to perform connections. The method of connection differs depending on the control unit, video equipment and other units being used.

① AUDIO OUT

These jacks provide the left and right channel audio signals for connection to a stereo hi-fi system.

② EXT CONTROL

This terminal is used as an I/O port when the player is controlled by a controller.

③ VIDEO OUT

The terminal is for connection to a color video monitor TV or other video equipment (that have video input terminal). It provides the direct video signal.

④ POWER CORD

Plug this into a wall socket.



4. DISASSEMBLY

1. ENCLOSURE AND PCBS

A

B

C

D

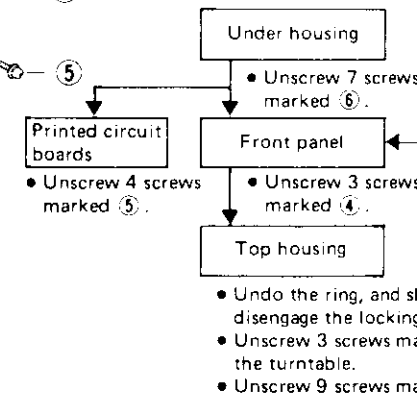
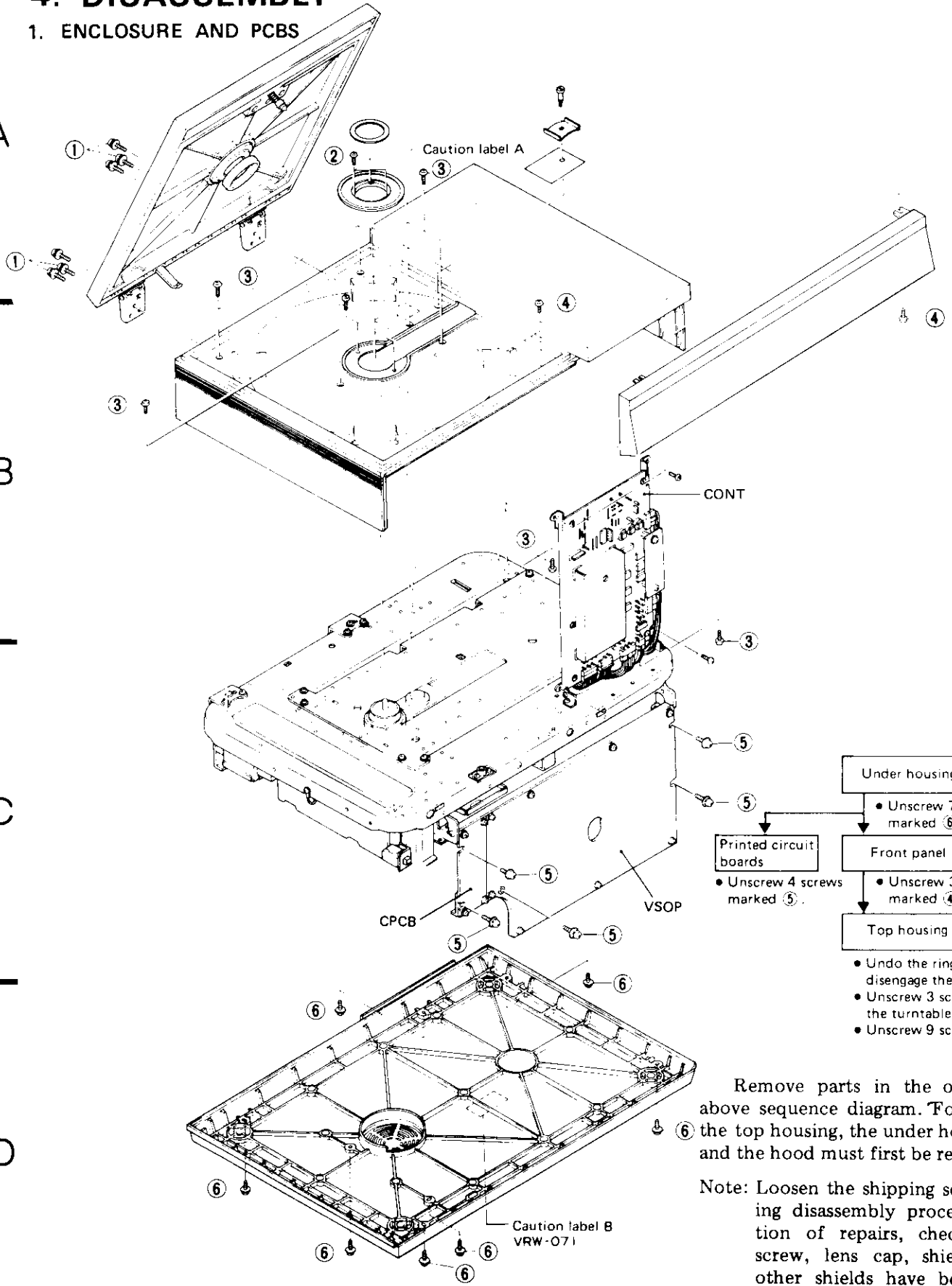

Remove parts in the order above sequence diagram. For example, to remove the top housing, the under housing and the hood must first be removed.

Note: Loosen the shipping screw before beginning disassembly procedures. In the event of repairs, check that the shipping screw, lens cap, shield cap, and other shields have been returned to their original positions.

4

5

2. HOW TO REMOVE SLIDER FROM MECH-CHASSIS

1. Remove the four fixing screws on the VSOP board, and open the VSOP.
2. Put the slider harness out of the joint by removing the E washer, and disconnect the housings N4, N5, and high voltage cap.
3. Remove the two screws installed the slider-pot assembly.
4. Remove the four screws installed the rail near the slider pot.

A

B

C

D

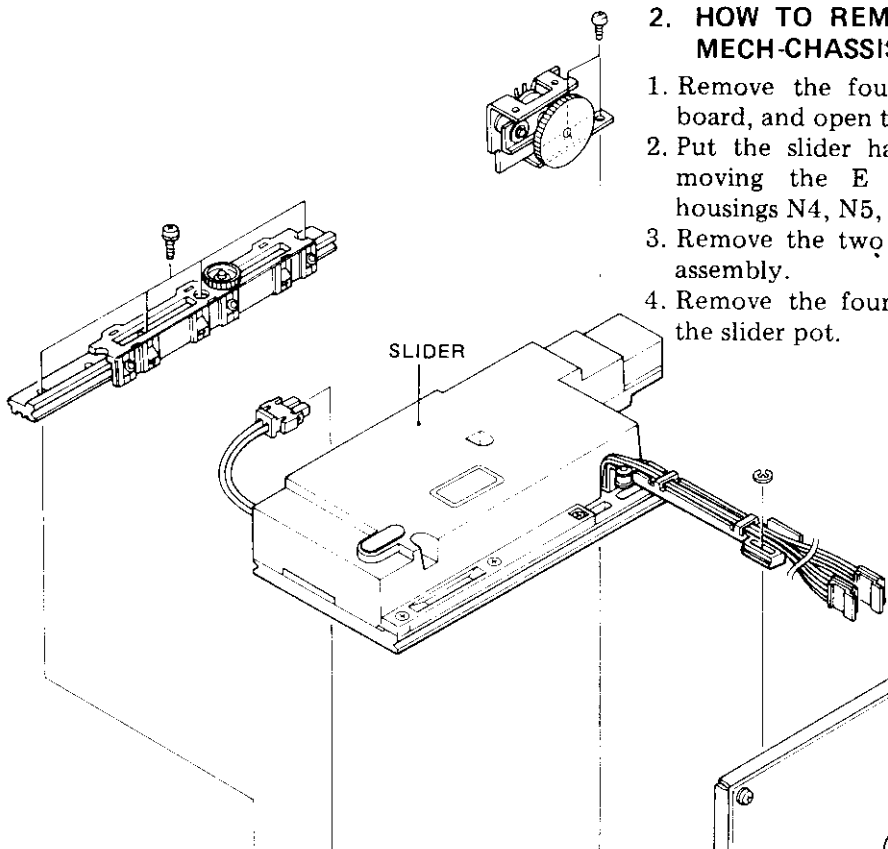

WARNING: EXTREME CARE MUST BE EXERCISED TO "LSPS" BOARD WHILE WORKING WITH THE PLAYER TO PREVENT POSSIBILITY OF EXPOSING YOURSELF TO DANGEROUS VOLTAGES.

- er housing
- Unscrew 7 screws marked ⑥.
- ont panel
- Unscrew 3 screws marked ④.
- o housing
- do the ring, and shift to one side to engage the locking catches.
- Unscrew 3 screws marked ②, and remove turntable.
- Unscrew 9 screws marked ③.

Hood

• Open the hood, and unscrew 6 screws marked ①.

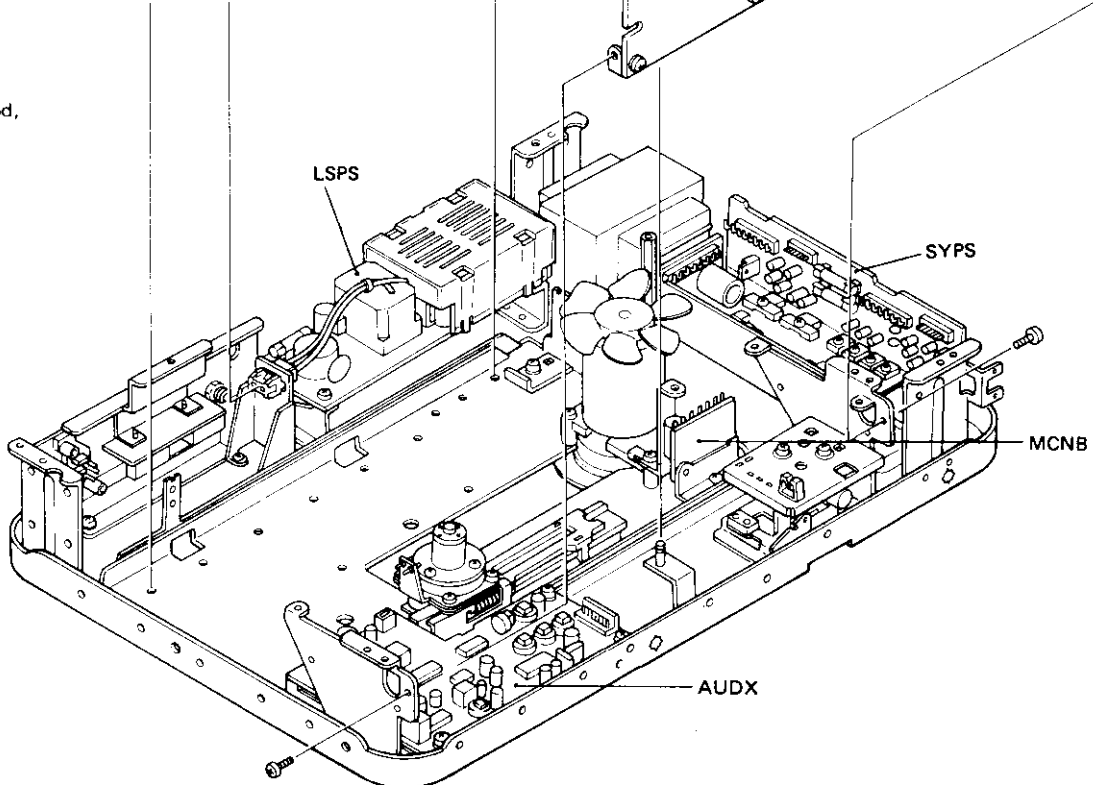

the order indicated in the diagram. For example, to remove the under housing, the front panel must be removed.

loosening screw before commencing procedures. Upon completion, check that the shipping cap, shield case, barrier, and cover have been fixed in suitable

7

4

5

6

8

5. CIRCUIT DESCRIPTIONS

5-1 RFAM

RFAM consists of PHDB (photo detector board) and HEDA (head amp) is mounted on the slider assembly. The photo detector mounted on PHDB picks up the various signals, and after passing them through a filter choke to eliminate the 620MHz spurious signal generated by the laser tube, outputs them to HEDA.

The FM signal is amplified by about 20dB by the negative feedback amp. Transistors Q1 and Q2 form a cascade connected amplifier stage, and Q3

is an emitter follower. The RF OUT signal is extracted from this point.

The four focus control signals are B1 thru B4. The sums of B1 and B3, and the sums of B2 and B4 are sent to their respective OP amps (Z2) where they are amplified about 17dB, then output as FOCS A and FOCS B signals. Tracking control signals A and C are input to the voltage-follower type OP amp Z1, and extracted as TRKG A and TRKG B output signals.

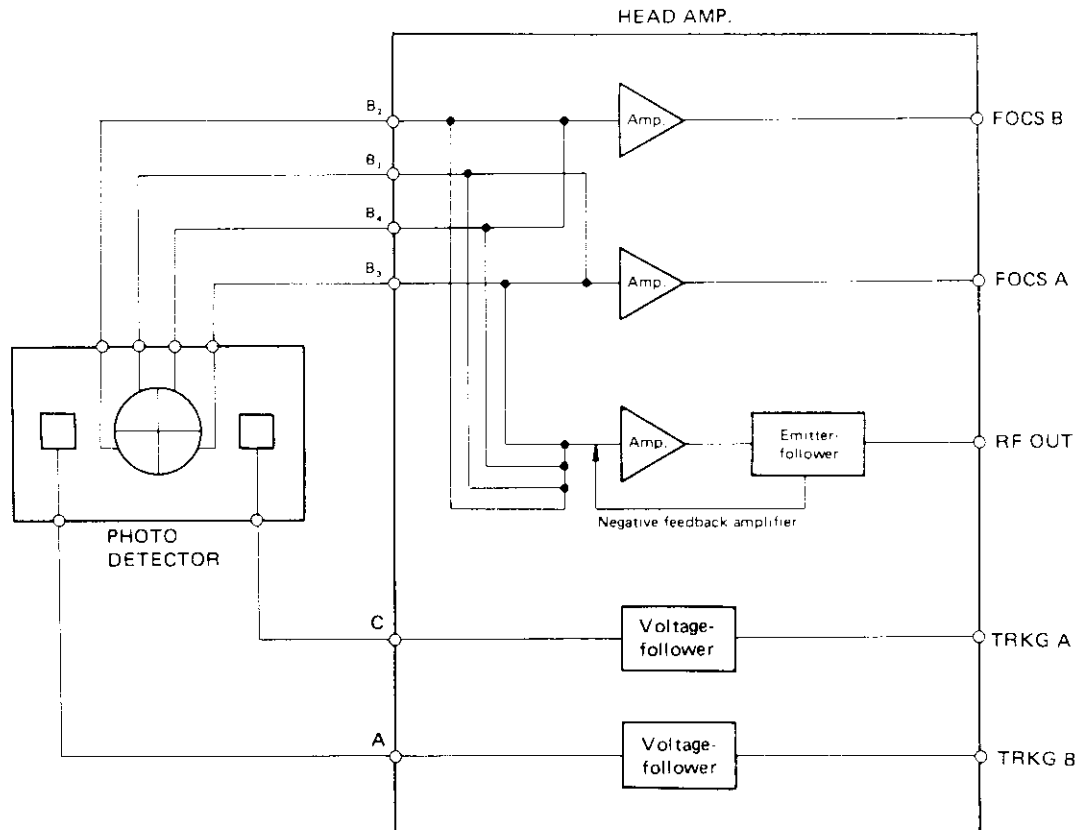

RFAM BLOCK DIAGRAM

Fig. 1 RFAM block diagram

5-2 VDEM (VSOP)

With the UA5002 DOC processor and the UA5001 video processor IC, the VDEM section which occupy 1/3 of the VSOP board handles video signal demodulation and 1H delay video signal demodulation plus video signal switching when dropouts occur. A block diagram of the VDEM section is shown in Fig. 2.

The video and audio FM signals applied to the VSOP board from the RFAM board are applied to the RF correction circuit (Q201~Q203). Since the electrical conversion frequency response is lower at the inner circumference than at the outer circumference, there is a certain amount of gain compensation up to frame number #13500 (approx), especially in the high frequency

region where the effect is much greater.

Following compensation of the gain difference between inner and outer circumferences, the FM signal is passed to the AUDX board and to the UA5002 DOS RFIN terminals. This signal is also passed through a bandpass filter for video FM signals, and then through an audio FM signal trap in order to extract the video FM signal components. After being applied to pin 24 of UA5001, this FM signal is amplified by Q208 and Q220, detected (level detection), and then applied as the RF sensor output to UM3002 in the SPDL section. Furthermore, the video FM signal delayed by an interval of 1H by the 1H delay line is applied to pin 7 of the UA5002 DOC processor.

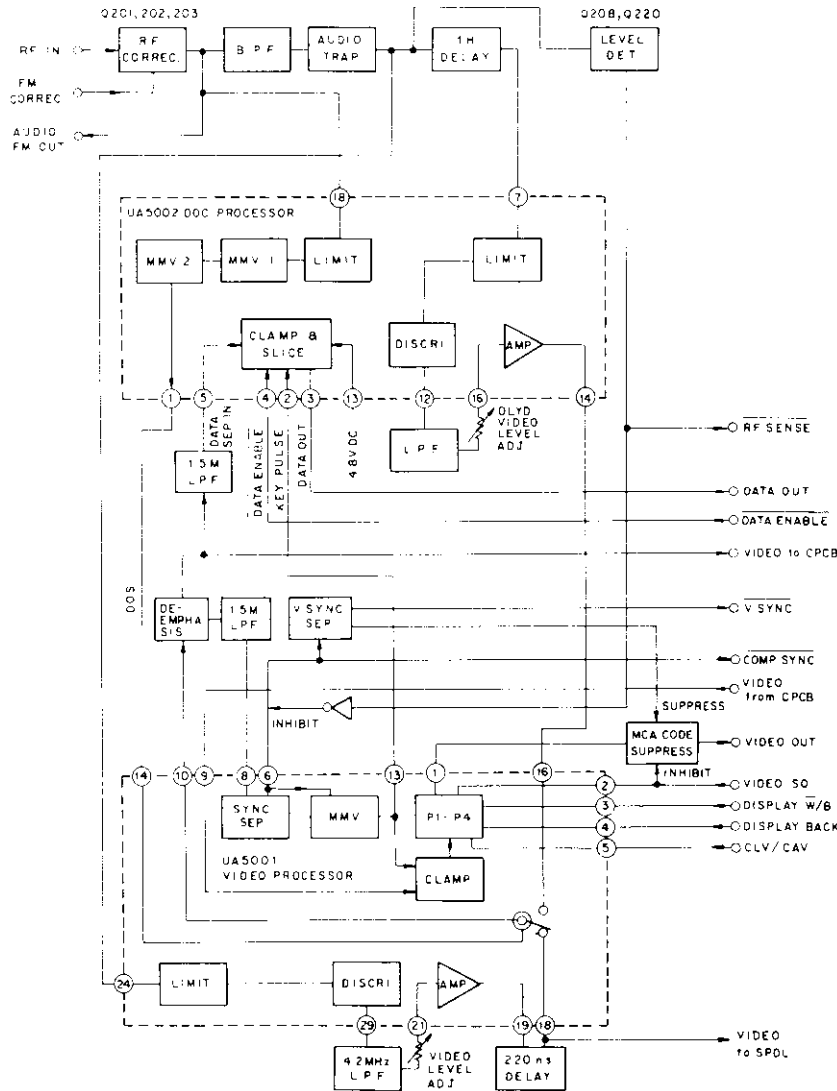

Fig. 2 VDEM section block diagram

Function explanatory diagrams for each function block in UA5001 are outlined in Fig. 3. And waveforms on each terminals are shown in Fig. 4. After aligning the amplitudes of the video FM signals applied to pin 24 by internal limiter, an output signal is obtained from pin 29 (with an external resistor serving as the load), this signal consisting of a frequency (16MHz) twice that of the carrier signal added to the video signal. However, since this signal has not yet been passed through the de-emphasis stage, the high frequency components will still be raised. The video signal detected in the discriminator is passed through a 4.2MHz lowpass filter before being applied to the pin 21 video amplifier where the gain is about 31 to 32dB. The amplified video output signal appearing at pin 19 is passed through a 220ns delay line and then applied to the next DOS switch. (In this model, the video signal is also applied to the SPDL section after the 220ns delay line.) This DOS switch includes 2 inputs — pin 18 for the main line video signal input, and pin 16 for the 1H delay video signal input, plus pin 14 for the "DOS" switch control signal. The output appears at pin 10. The pin 18 input appears at the pin 10 output when pin 14 is at L level, while the pin 16 input

appears at pin 10 instead when pin 14 is at H level.

The DOS switch output is passed through the de-emphasis stage and is then applied to CPCB board and a synchronizing separator circuit. The CPCB board is a feed forward circuit which controls phase of chroma components in the video signal, and serves to eliminate color bands and color irregularities in the picture. In addition to separating the synchronization signal, the synchronizing separator circuit also includes a noise cancellation function. Any noise components exceeding the input video signal sync tip level in the negative direction by more than about 0.5V is not accepted as a synchronizing signal, and is not, therefore, included in the synchronizing separator signal output.

In addition to triggering the internal MMV, this synchronizing separator output signal appears at pin 6 as a composite synchronizing signal output. In this model, this composite synchronizing signal is applied to the V synchronizing separator where a signal is generated (and applied to the SPDL section) in order to cover the V blanking interval of about 15H from the vertical synchronizing signal. If the FM signal level is not detected, however, this composite synchronizing signal is inhibited.

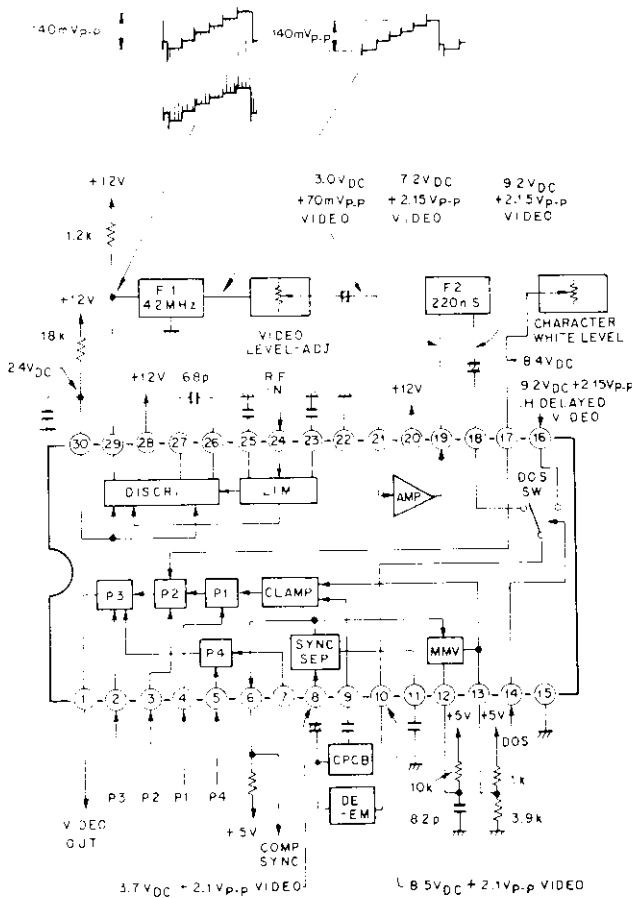

Fig. 3 UA5001 block diagram

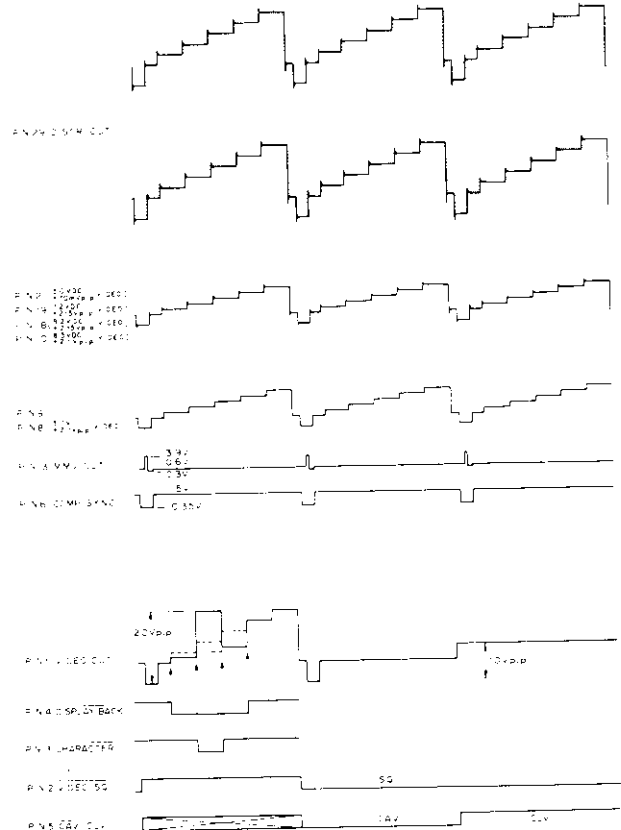

Fig. 4 UA5001 waveforms on each terminals

The MMV triggered by the composite synchronizing signal generates a clamp pulse for keyed clamping of the input video signal applied via pin 9 from the CPCB board. This clamp pulse is also employed as the UA5002 clamp pulse. The clamped video signal is passed via switches P1, P2 and P3, the output appearing at pin 1.

At the P1 switch, the video signal is switched to a signal of half the video level by a display background signal. The P2 switch switches the video signal and the character signal with white level, and in this case, the switched character white level can be adjusted by the voltage applied to pin 17. The P3 switch is involved in video squelching and switching of the video signal with the P4 switch output. When using CAV discs, switch P4 applies the composite synchronizing signal to pin 7 for "soft clamping" purposes, and extracts the signal again when the input level on pin 2 of the P3 switch is changed to L level.

The level of the MCA code which exists within the V blanking interval of the video signal output from pin 1 is suppressed by 70%. The reason for this is to prevent the appearance of the MCA code in the screen during the fly-back period in certain types of TV sets. This operation is inhibited during video squelching.

Fig. 5 outlines the internal functional blocks in the UA5002 DOC processor, and also an example of general application. The delayed video signal applied to pin 7 via the 1H delay line is demodulated by a discriminator circuit (of same composition as the discriminator circuit in the UA5001) with an external resistor connected to pin 12 serving as the load. As can be seen from the discriminator stage signal waveform diagram, the frequency component with a frequency twice that of the carrier frequency is still included in the signal at this stage, but is eliminated by a low-pass filter connected to the load resistor.

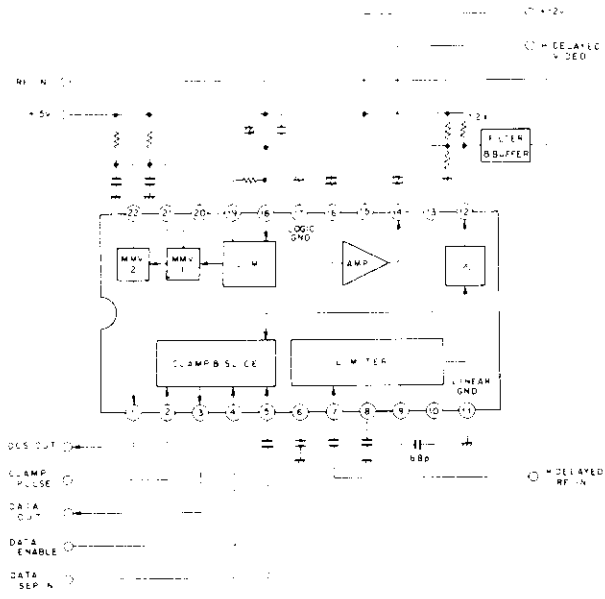

Fig. 5 UA5002 block diagram

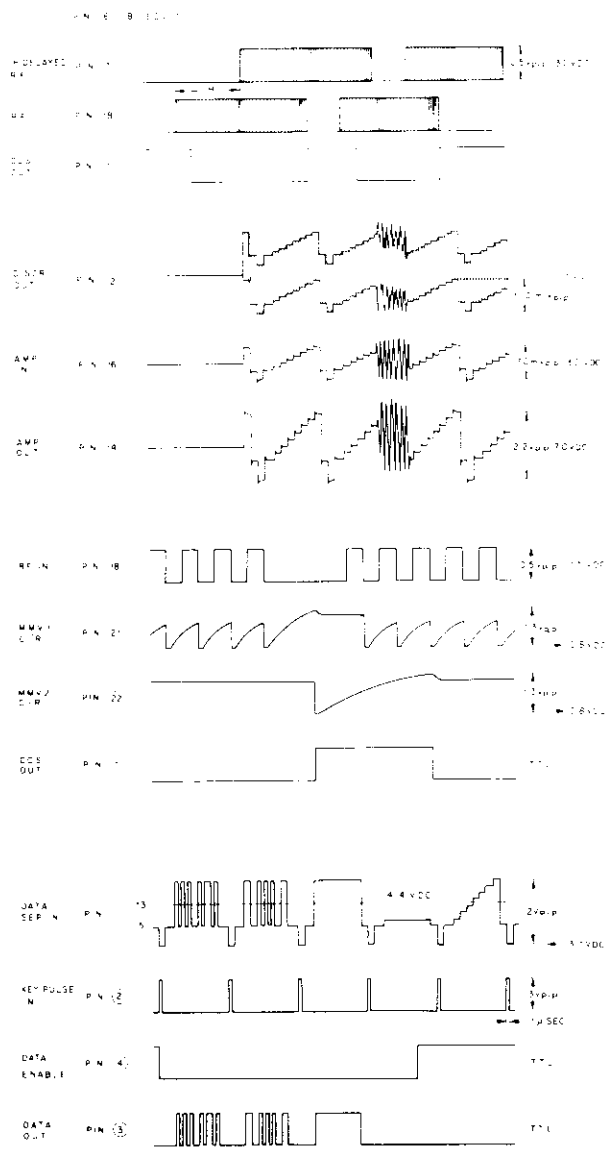

Fig. 6 Waveforms at UA5002 each terminals

The video signal applied to the amplifier connected to pin 16 is amplified by about 30dB in order to obtain a video signal of the required level from pin 14, and since this signal has not been passed through a de-emphasis stage yet, the high frequency region of the signal is boosted as shown in the signal waveform diagram. This signal is applied to pin 16 of UA5001 for compensation purposes when drop-outs are generated.

The FM signal applied to pin 18 is also applied to the limiter and then retriggeres the retriggerable MMV1. During this retriggering action, the MMV1 output is maintained at L level, resulting in the MMV2 output also becoming L level. If, however, a drop-out exists in the input FM signal, the MMV1 retriggering action stops, and the MMV2 is consequently triggered. This results in a DOS signal

output of constant width from pin 1. The resistor and capacitor connected to pin 21 are used in deciding the MMV1 output pulse width (i.e. the detected drop-out width), while the resistor and capacitor connected to pin 22 determine the MMV2 output pulse width, i.e. the width of the pulse added to the drop-out.

The video output signal from pin 10 of UA5001 is passed through the de-emphasis stage, and then applied to the CPCB board. This signal is also applied to pin 5 of UA5002 in order to extract the phillips code present in the vertical blanking interval. This video signal is then synchronized and clamped by the clamping pulse applied to pin 2, sliced by the DC voltage applied to pin 13, and then appears at the pin 3 output only while the DATAENABLE signal applied to pin 4 is at L level.

5-3 AUDX

Following compensation for level differences between the inner and outer tracks by the RF correction circuit in the VDEM stage, the RF signal is passed to the AUDX board which includes the audio FM detectors, the output selector switches, and the CX noise reduction system decoder. (See block diagram in Fig. 7 below.)

The RF signal applied to pin 1 of the AUDX board is first applied to a low-pass filter where the video FM signal is removed, the RF signal then being amplified by about 37dB. The 1/left and 2/right channel audio FM signals which serve as the respective frequency carrier signals are extracted by 2.3MHz and 2.8MHz band-pass filters, and subsequently passed to the FM detector stage (a quadrature detector utilizing PA3001A).

These demodulated audio signals are applied to respective switching circuits via the audio output level setting controls VR1 and VR2. When the AUD1 and AUD2 signals from the CONT board are applied, S1 and S2 are switched on and S3 switched off, resulting in the 1/left and 2/right channel output signals appearing at the switching circuit outputs (A) and (B) respectively. If, however, the AUD1 (or AUD2) signal is not received from the CONT board, S2 (S1) and S3 are switched on and S1 (S2) switched off, resulting in the 2/right channel signal appearing at both switching circuit outputs (A) and (B). And if neither the AUD1 nor AUD2 input signal is received, S1 and S2 are switched off and S3 switched on, thereby preventing either channel signal from appearing at the (A) and (B) outputs.

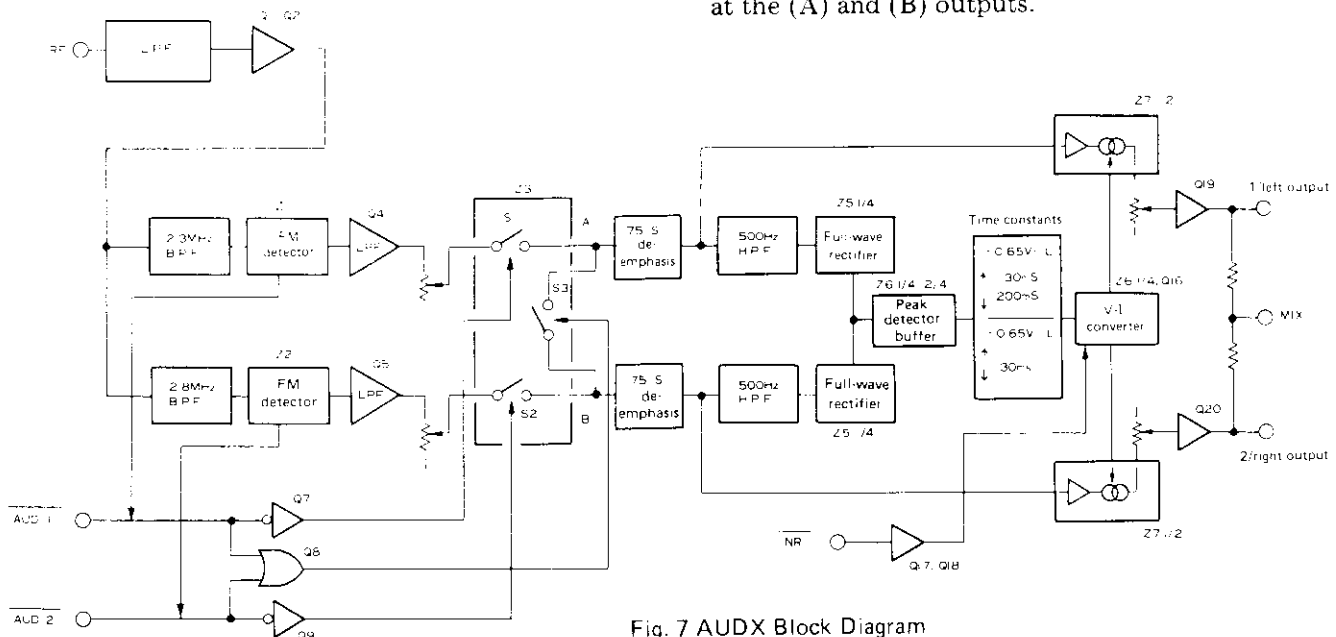

Fig. 7 AUDX Block Diagram

An audio squelch is used to suppress the noise level in the audio output at times when the level of the detector input FM signal is low (such as when the player is first started). In this case, S1 and S2 are switched off and S3 switched on by using the PA3001A AGC output without involving the AUD1 and AUD2 signals from the CONT board.

The audio signals appearing at the switching circuit outputs (A) and (B) are passed through respective $75\mu\text{s}$ de-emphasis circuits (R18/C14 and R39/C40) before being applied to the CX noise reduction decoder.

This CX noise reduction system reduces unwanted noise by compressing the dynamic range during recording and expanding it again during playback. This system was originally developed by the CBS Research Laboratories for noise reduction in LP records, and has now been modified for use in video discs.

The dynamic range compression and expansion characteristics of this system are dependent upon the following four conditions.

- (1) The compression and expansion actions must have no effect on the audio frequencies.
- (2) The levels (in dB) of signals greater than -28dB (with reference level of 0dB) must be compressed linearly in a proportion of 2:1, and the level of signals greater than -14dB must be expanded in a proportion of 1:2.
- (3) The frequency of signals compressed and expanded must be at least 500Hz .
- (4) The compression/expansion control signal is to employ a variable time constant circuit which varies according to audio amplitude level changes.

The block diagram of the CX noise reduction compressor stage is outlined in Fig. 8, the circuit composition being the reverse of the CX expander stage shown in the block diagram in Fig. 7. Reliability of these circuits is ensured by using the same circuit for the compressor feedback circuit and the expander feed forward circuit.

In the compressor, the input signal is passed to a VCA where part of the output is passed through a high-pass filter for peak detection, resulting in a DC voltage being generated at the output of the time constant network. This DC voltage is converted to a current by the V-I converter, the VCA amplification being controlled by the size of the current. The output level therefore varies according to the input signal level. The compression/expansion characteristics of the CX NR system for a 1kHz signal are outlined in Fig. 9.

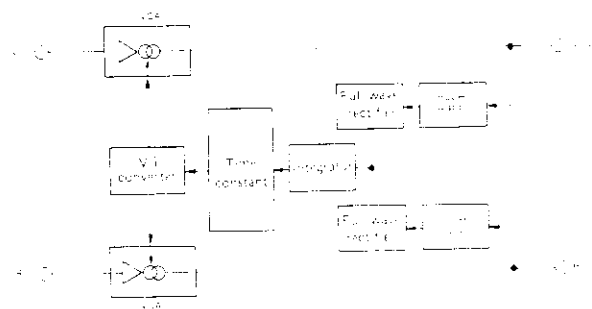

Fig. 8 CX NR system compressor: block diagram

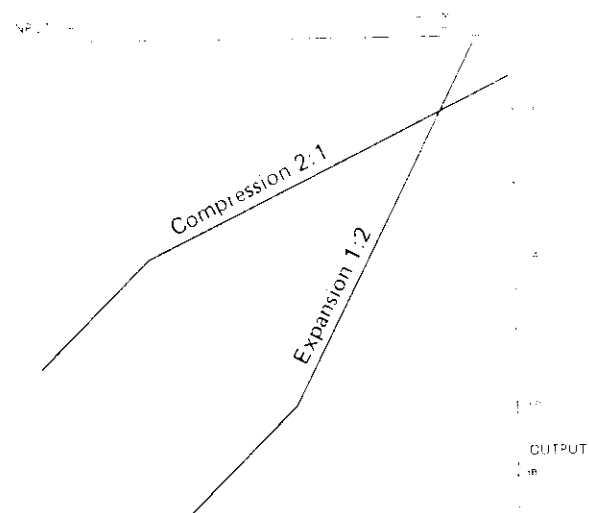

Fig. 9 CX NR system compression/expansion characteristics

With 40% modulation (frequency deviation \pm 40kHz) as the system reference level (0dB), signals with a level greater than -28 dB are subjected to 1:2 logarithmic compression. Signals of lower level are not compressed.

The basic attack time determined by the time constant network used by the compressor and expander is 1ms for sudden large increases in amplitude, and 30ms for more gradual large amplitude increases. The recovery time is 200ms for decreases of large signals, while the attack and recovery time for small signal amplitude changes is 2 seconds.

The demodulated audio signals passed through the 75μ s de-emphasis circuit are applied to current-controlled variable gain amplifiers (consisting of Z7). Part of the de-emphasis output is also passed through a 500Hz high-pass filter (C61/R75 and C62/R80), amplified by Z5 (1/4) and Z5 (3/4), and rectified by the full-wave rectifier consisting of Z5 (2/4), D2, D3, and Z5 (4/4), D4, D5. Due to the forward characteristics of the diodes, this rectifier circuit has a dead zone which ensures that signals below \pm 0.6V do not appear at the output.

With this circuit composition, the expander gain for input signals below -14 dB (reference value) can be kept at a constant value of -14 dB.

Following mixing of the rectifier outputs, bias is applied by Q13, D1 and R83 and addition to D2-D5 temperature compensation. This output is then received by the Q14 emitter-follower while also being subjected to a DC shift. The emitter-follower output is applied to the circuit formed by Z6 (1/4), D6, R85, R86 and C63 for peak level detection and smoothing purposes. This circuit has an attack time of 1ms and a recovery time of 10ms. The filter output is then applied to a time constant network via the Z6 (2/4) voltage-follower.

The attack time of 30ms in this circuit is determined by D7, R87 and C65, while the recovery time of 200ms is determined by D8, R89 and C65. However, due to the dead zone formed by the forward characteristics of D7 and D8, the attack and recovery times for small level changes are determined by R88 and C65, the value being 2 seconds for both times.

The output is then passed to the Z6 (3/4) voltage-follower and Z6 (4/4). C64, R90 and R92 form a high-pass filter, the output being applied to the Q15 emitter-follower (which can also be considered a positive voltage half-wave rectifier with a 0.7V dead zone). This circuit operations in conjunction with the D7, R87, C65 circuit in achieving an attack time of 1ms for sudden increases in high level signals.

The output from this time constant network is applied to a V-I converter formed by Z6 (4/4) and Q16. The Z7 gain is controlled by the Q16 collector current, resulting in CX expander input/output characteristics as shown in Fig. 9.

5-4 FOCUS SERVO

Due to the ingenious combination of cylindrical lens and 4-way divider photo-detector, the laser beam reflected from the disc into the photo-detector mounted on the slider results in the generation of a focus error signal where the variation between output level and the distance between the objective lens and disc describes an S curve. By utilizing the linear section of this focus error signal variation curve (S curve), changes in the distance between the objective lens and the disc can be detected and employed in a focus servo mechanism. After this focus error signal is amplified in the RFAM board and processed in the VSOP, it is further amplified (current amplification) in the SYPS board in order to drive the focus motor. In this way the focus motor (objective lens) is operated to maintain focussing error constantly at zero, thereby ensuring that the laser beam is accurately focussed on the disc at all times.

When starting, the objective lens is first raised (as a result of the FOCUS ON command from the CONT board) to a position where the focus servo can be applied, and once the beam is properly focussed ("in focus") the focus servo loop is closed

and a FOCUS LOCK command output is sent to the CONT board. The focus servo is thus set to normal operating status, but if proper focussing cannot be achieved within 1 sec after the application of the FOCUS ON command, this command signal will be stopped temporarily and the focussing operation retried 4 times. If it is still not possible to lock the focus servo mechanism, the player is switched automatically to reject mode.

Starting operation

The focus servo mechanism block diagram is outlined in Fig. 10 and the timing sequence chart is shown in Fig. 11. Until the PLAY key is pressed after switching the power on, the FOCUS ON input command is not applied. And with the application of the L level output from the Q5 inverter, the Q2 analog switch remains off. The Q8 inverter output is likewise kept at L level, and a DC voltage of approximately -30mV is applied to the Z2 (1 2) driver amplifier input, thereby keeping the focus motor pulled downwards. The Q4 inverter output, on the other hand, keeps the Q6/Q7 loop flip-flop output at L (Q6) and H (Q7) levels.

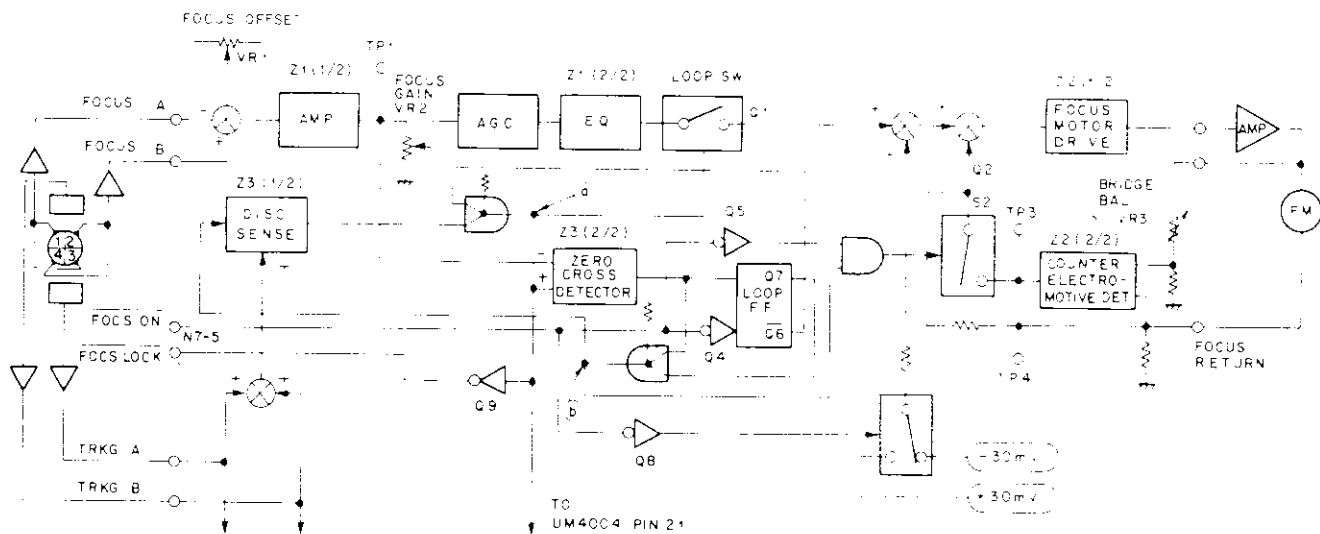

Fig. 10 Focus servo block diagram

When the PLAY key is pressed, the FOCUS ON command from the CONT board is applied to the VSOP board, while at the same time, the LASER ON command is applied to the LSPS board, resulting in the laser generator being switched on. Due to the application of the FOCUS ON command the Q5 inverter output is switched to H level, resulting in this output combining with the Q7 H level output to turn the Q2 analog switch on. And due to the Q8 output, S3 is inverted and a +30mV DC voltage is applied to the Z2 (1/2) input. The circuit constituted by D7, D8, and C11 is for applying a pulse differentiated by a time constant of C11, R52 and R53 to Z2 (1/2), and operates for decreasing a static frictional force of the focus motor while beginning of the focus motor raising operation, and also increasing a focus motor torque lowered by unbalanced focus bridge. This +30mV DC voltage is amplified in Z2 (1/2) in order to raise the focus motor to the required position. The counter electromotive force appearing between the focus motor terminals at this time as detected (level detection) by the Z2 (2/2) counter electromotive force detector circuit via a bridge circuit, and is then applied to the Z2 (2/2) amplifier as a negative feedback signal. The focus motor can thus be raised at a constant velocity.

When the focus motor is raised to about 60 μm below the proper focusing position, tracking error will commence to appear. This tracking error is generated in A and B forms, and appears as an output from the RFAM board. These signals are added and applied to the Z3 (1/2) disc sensor comparator input. The output from the Z3 (2/2) zero-cross detector is an H level output, and increases the disc sensor comparator threshold level in the (+) direction. When the tracking error level is increased to a value in excess of the threshold level, the output of Z3 (1/2) is switched to H level. The reason for increasing the disc sensor comparator threshold level at this time is to eliminate the effect of the reflected beam from the disc surface (protective plastic surface).

When the objective lens is raised further, focus error is generated, resulting in A and B focus error signals from the RFAM board being applied to the Z1 (1/2) differential amplifier input. The focus error appearing at the output of the Z1 (1/2) amplifier is applied to the zero-cross detector (-) input. If the objective lens is raised still further, the focus error change will reach the non-linear section of the S-shaped curve, and at the point where the threshold level determined by the (+) input voltage is exceeded, the detector output will be switched to L level. The loop flip-flop outputs Q7 and Q6 will thus be switched to L and H levels respectively,

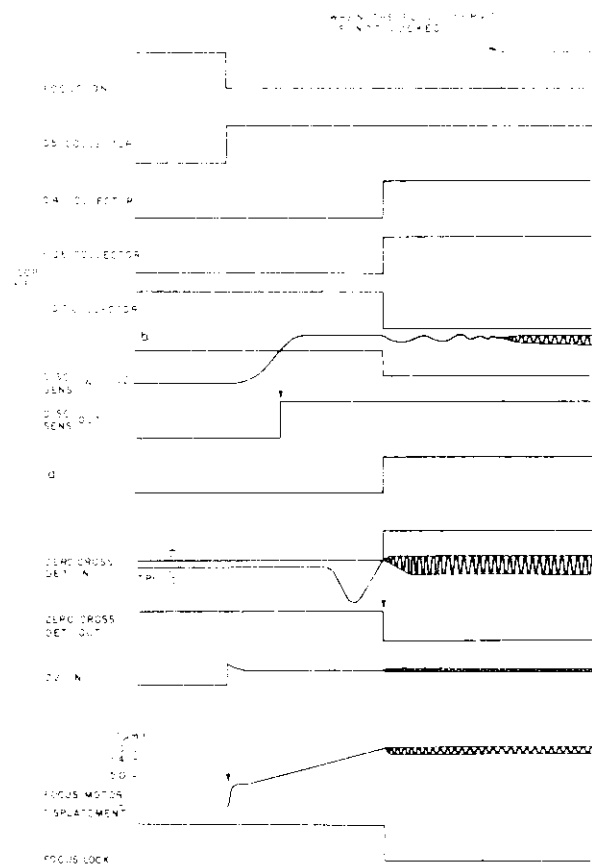

Fig. 11 Focus servo timing chart

thereby closing the Q1 loop switch, and resulting in the closure of the focus servo.

At the same time, the zero-cross detector threshold level is raised in the (+) direction, and the disc sensor comparator threshold level is reduced by about +0.2V, followed by the FOCUS LOCK command signal being sent to the CONT board. And thereafter, the focus servo mechanism is in normal operating mode.

Normal Operation

Focus error A, B is amplified by a differential amp consisting of Z1 (2/2). VR1 serves as the overall voltage adjustment for focus offset caused by the RFAM section DC offset voltage, photo detector sensitivity corrections, slight deviations from the optical focus point, and other factors.

The focus error that appears in the output of Z1 (1/2) passes through VR2 to set the loop gain and then enters the AGC circuit. When the loop gain is raised above the level normally required, noise generated in the system is caused by the increasing amount of static generated by the focus motor. Also, the system becomes susceptible to

defocusing due to tracking mirror movements during scanning and other similar operations. However, when the gain is small, it is possible that the focus offset voltage will not be able to keep up with the focus servo (the input disturbances). To prevent this, gain is automatically raised only when setting the loop gain so that VR2 has a stable and sufficient gain at the same time there is a great deal of disturbance in the AGC circuit. This operation is performed by D1, D2 and C2, C3, and R9 in reverse parallel connection.

Z2 (2:2) forms an equalizer to stabilize the loop. During standard operation, the loop switch is left on by Q1, and the focus error is amplified by the drive amp as controlled by Z2 (1/2). As described earlier, the output of this drive amp is current amplified in the SYPS amplifier and drives the focus motor.

5-5 TRACKING SERVO AND SLIDER SERVO

The major component in the tracking and slider servo systems is the UM4004 TRKG IC. See the block diagram in Fig. 12.

The photo-detector outputs from both sides of the center segments divided in 4 parts on the slider are amplified by the RFAM, and then applied to N4-7 and N4-8 in the VSOP board. The difference between these signals is extracted in Z4 (1/2) and is applied to Z4 (2/2) as the tracking error. Q10

forms part of the Z4 (2/2) feedback loop, and due to the slider potentiometer output the change in resistance across the D-S interval is practically linear from the inside to the outside circumference of the disc. Consequently, the loop gain at the outside disc track is increased approximately 4dB compared with at the inside disc track. The tracking error amplified by Z4 (2:2) and compensated for level differences between inside and outside tracks is applied to UM4004 via VR5. This VR control is used to ensure optimum loop gain adjustment for the tracking servo.

The major components incorporated in UM4004 are described below in a little more detail.

AMP1 and AMP2 form the tracking servo op. amp. stage, while switch 1 operates as the servo loop open/close switch. The loop is open when the switch is on, and closed when the switch is off. AMP3 and AMP4 form the slider servo op. amp. stage with switch 2 serving as the servo loop open/closed switch. The loop F.F. circuit opens and closes the loop by controlling switches 1 & 2.

There are 3 comparators. COMP1 detects the zero cross-point of the tracking error signal for determining the loop closing timing. COMP2 is a window comparator which is applied an input voltage corresponding to the degree of rotation in the TRKG mirror, and is used in limiting the mirror's field of vision. COMP3 is not used in this model.

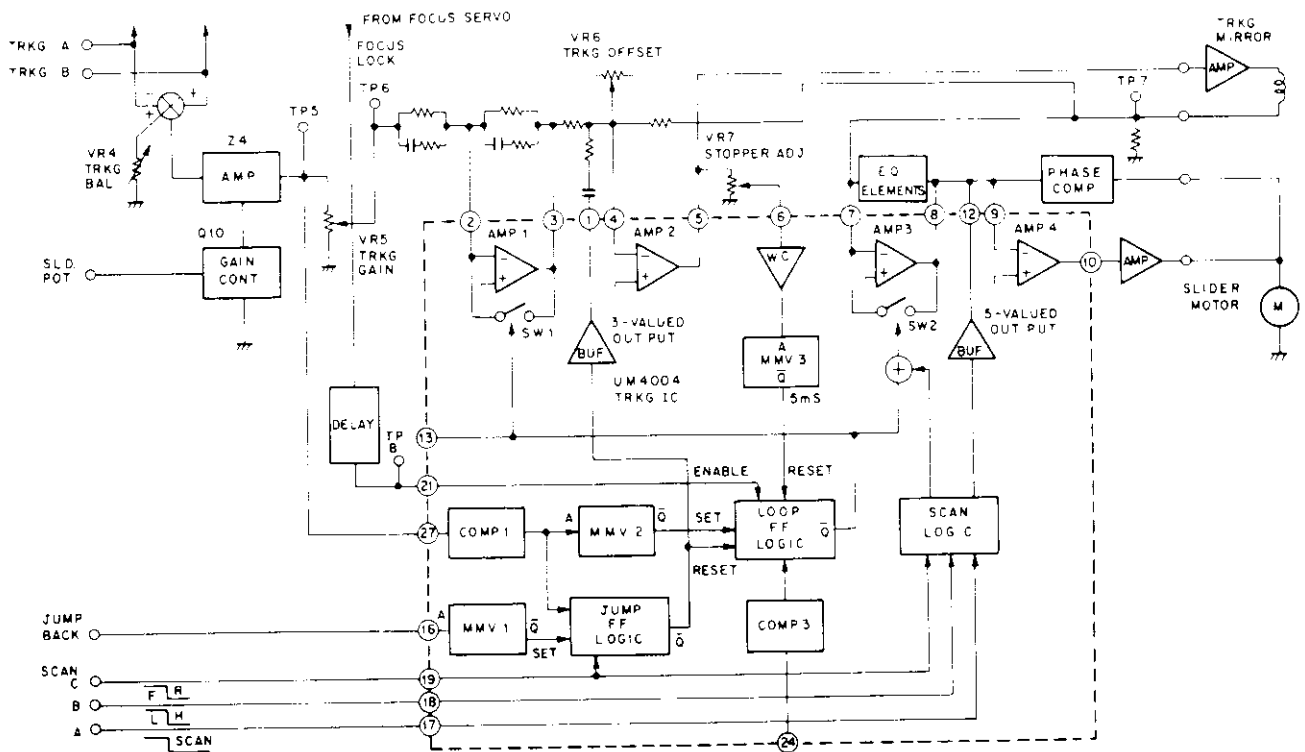

Fig. 12 Tracking & slider servo block diagram

There are also 3 MMV components. MMV1 is triggered by a jump-back trigger signal from the CONT board, and sets the jump F.F. by generating pulse outputs of approx. 100 μ s. MMV2 is triggered by a pulse corresponding to the zero cross-point of the tracking error. Since MMV2 is a re-trigger type component with an output pulse width set to about 100 μ s, an L level output will be maintained without inversion while the trigger pulse repetition frequency is more than 10kHz. MMV3 is triggered by the output of the window comparator in the previous stage, resulting in the generation of output pulses of about 5ms in width which serve as resetting signals for the loop F.F. in the next stage. Pin No. 1 is for jump pulse outputs generated when the jump F.F. in the next stage is set by the MMV1 output. Although the output pulse polarity is determined by the SCAN C signal, only the -6.6V output is obtained in this model. Pin No. 12 is for the DC outputs employed to drive the slider during scan mode. There are 5 output voltages altogether, viz. +6.6V, -6.6V (high scan), +3.3V, -3.3V (low scan) and 0V, and these are controlled by the SCAN A, SCAN B and SCAN C input signals.

Start of initial tracking operation from set up mode:

When the PLAY key is pressed, there is a FOCUS ON command output from the CONT board, resulting in the start of focussing by the

focus servo mechanism. At the same time, the slider is moved initially in the forward direction by the SCAN A and SCAN C commands in order to locate the inside start position. After a delay of about 0.5 sec. following the FOCUS LOCK command from the focus servo mechanism, an input voltage is applied to pin 21 of UM4004, thereby switching the internal F.F. to enable status. And at approximately the same time, a tracking error signal is applied to pin 27, resulting in COMP1 being inverted by the zero cross-point of that signal. This is followed by triggering of MMV2, and 100 μ s later, the triggering of the loop F.F., resulting in the tracking and slider servo mechanisms being closed.

See Fig. 13 for an outline of the time chart of this initial tracking operation.

Scanning operation:

The time chart for the scanning operation is outlined in Fig. 14. When the SCAN REV key is pressed, SCAN A (L), SCAN B (H) and SCAN C (L) commands from the CONT board are applied to the UM4004, resulting in switch 2 being turned on by the internal scan logic, and the slider servo thus being made "open loop". At the same time, a -3.3V output voltage appears at pin 12. This voltage is inverted and amplified by AMP4, resulting in the slider being shifted in the reverse direction.

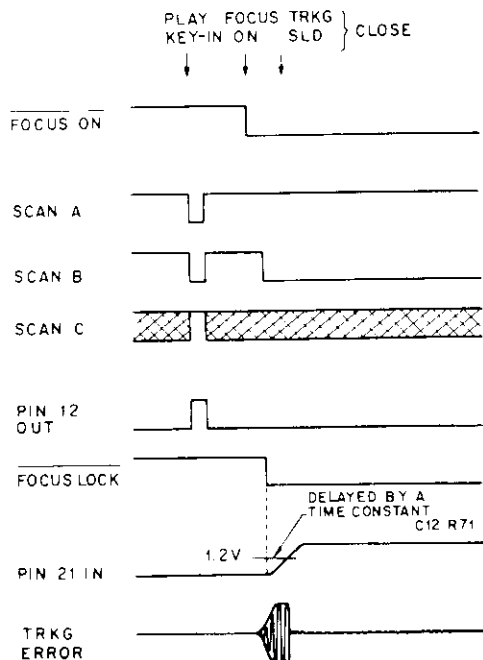

Fig. 13 Initial tracking operation timing chart

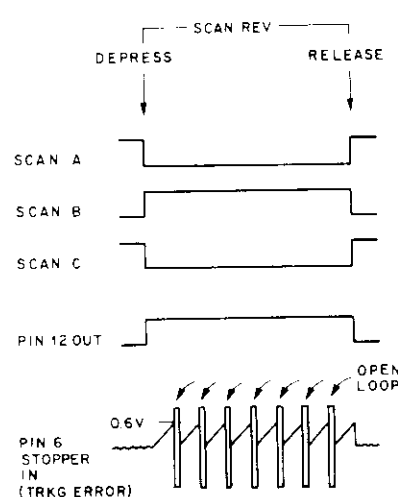

Fig. 14 Scanning operation timing chart

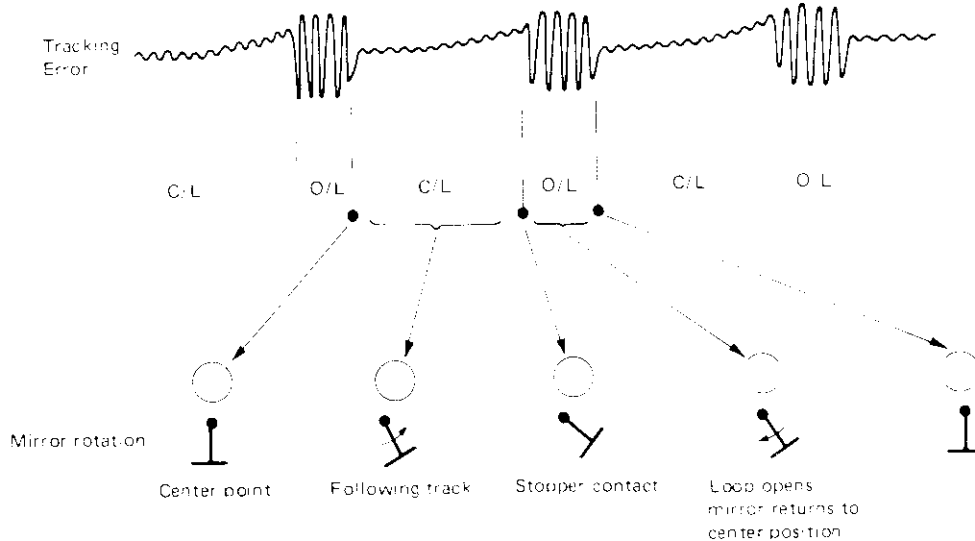

Fig. 15 Tracking mirror operation during scan mode

Although tracking of the disc track is continued while the mirror inclination is increased, the tracking error DC component is also increased, and when the input voltage applied to pin 6 exceeds +0.6V, the window comparator is activated and MMV3 triggered. The loop F.F. turns switch 1 on during the 5ms interval corresponding to the MMV3 output pulse width, resulting in the tracking servo being made "open loop". During this period, the mirror returns to the center position, the loop F.F. is set by the MMV2 output pulse, and switch 1 is turned off (i.e. the tracking servo is switched to "closed loop"). The movement of the TRKG mirror during scan mode is outlined in Fig. 15. The above operation is repeated continually during scan mode, but as soon as the SCAN key is released, the tracking and slider servo mechanisms are switched back to "closed loop" for normal operation.

During still/step and slow motion playback modes, jump-back trigger is also applied to the UM4004 together with the SCAN A (H), SCAN B (L) and SCAN C (L) commands from the CONT board. Although the output pattern of this jump-back trigger differ according to the type of playback mode, it is generated during the v blanking under Philips code control. (See the list of signals in the table referred to during the description of the CONT board).

MMV1 is triggered by the jump-back trigger applied to pin 16. This is then followed by the generation of a -6.6V jump-back pulse signal from pin 1 by the jump F.F., while at the same time the loop F.F. is also reset, resulting in the tracking

servo mechanisms being switched to "open loop". The jump-back pulse output signal from pin 1 is differentiated, level-adjusted by VR8, and then applied to AMP2.

The laser beam traverses the tracks as indicated in the time chart Fig. 16 and moves to an intermediate point between one track and the next. When the tracking error intersects the zero cross-point in the positive direction, the pin 1 jump-back pulse output returns to 0V resulting in the tracking loop being closed, and the differentiated DC voltage being applied to the AMP2 input in a direction which will suppress the inertial movement of the mirror.

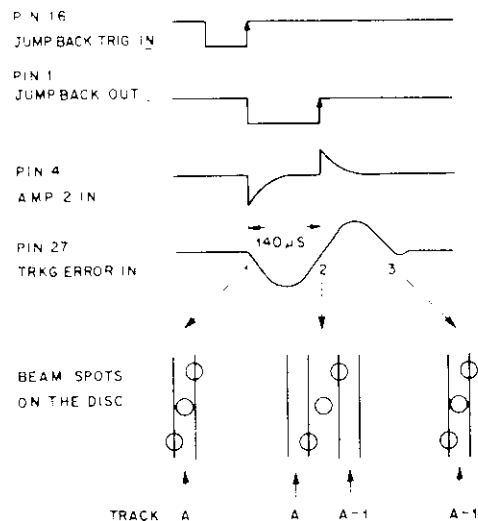

Fig. 16 Jump back operation timing chart

5-6 SPINDLE AND TANGENTIAL SERVO

1. General Outline

By comparing the phase of a reference signal with the phase of the synchronizing signal separated from the video signal reproduced from the disc, the spindle servo maintains the spindle motor rpm at a constant value. However, due to the disc eccentricity and track irregularities, time base errors of $30\mu\text{sp-p}$ are generated in the reproduced video signal, resulting in failure to obtain normal color in the reproduced picture (since the errors exceed the TV receiver color lock range). It is therefore, necessary to suppress the time base errors to a level not exceeding $20\mu\text{sp-p}$, and this is achieved by comparing the phase of the reproduced color burst with the phase of a reference oscillation signal, and subsequently driving a tangential mirror to control the tangential movement of the laser beam. For this purpose, the following 3 ICs are employed.

- (1) Control pulse generator IC (UM5003)
- (2) Tangential servo IC (UM3001)
- (3) Spindle servo IC (UM3002)

2. Control Pulse Generator Circuit

In order to generate pulses required for the tangential servo and spindle servo, this IC includes (1) burst gate, limiter and polarity inverter, (2) reference signal generator and frequency divider circuits, (3) Equalizing pulse eliminator circuit, and (4) Sampling pulse generator.

And the block diagram is shown in Fig. 17.

2-a Burst gate, limiter and polarity inverter

When the video signal is passed via C403 and applied to pin 5, a burst signal output is obtained from pin 3. Noise components in the signal are removed by the 3.58MHz tuning circuit, and the burst signal output from pin 3 is applied to the limiter where the signal is subjected to waveform shaping. Since the burst signal phase is inverted every H period, the phase is made uniform at every H period by the polarity inverter, thereby forming the sampling pulse signal for the tangential servo phase comparator.

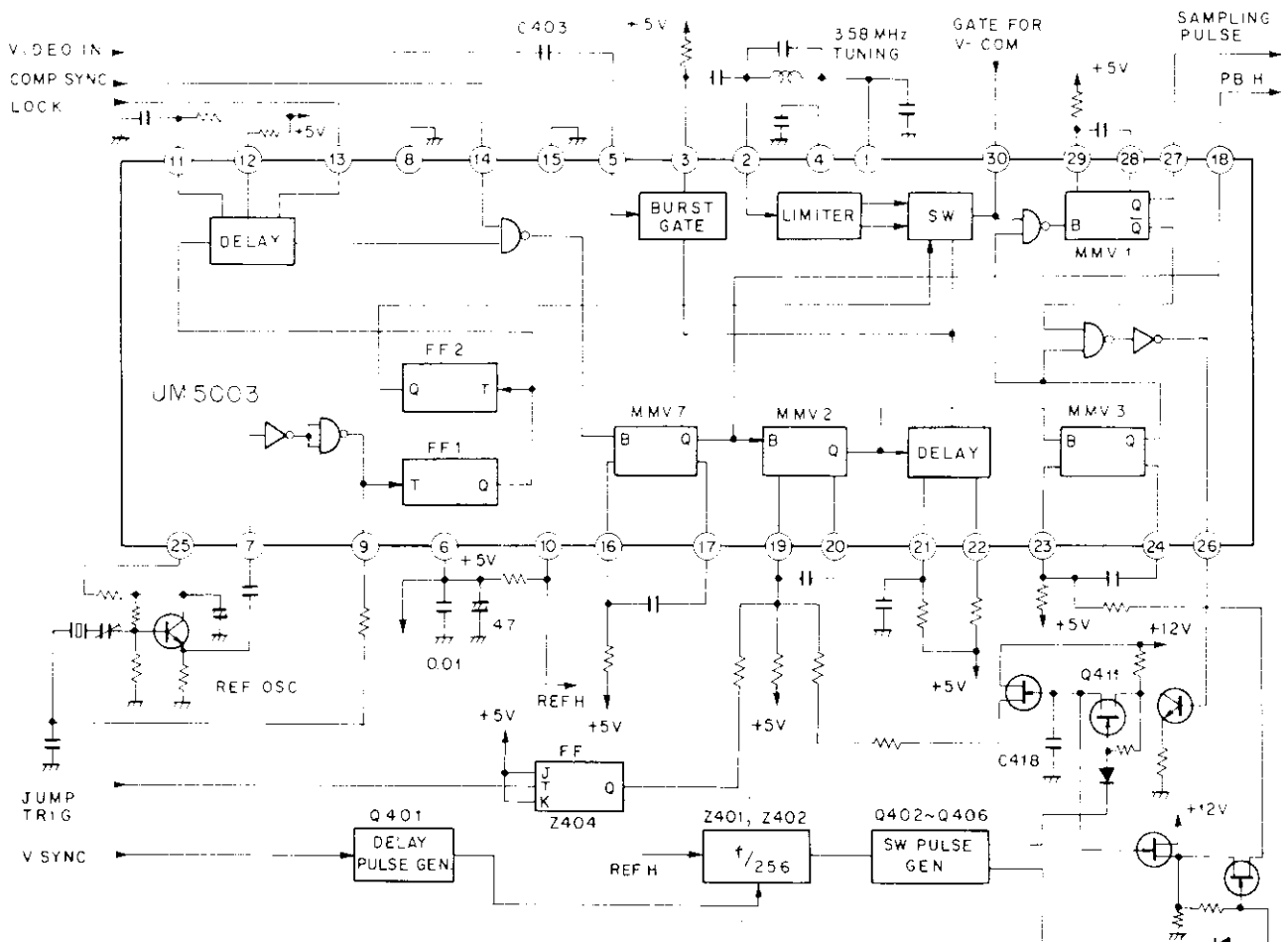

Fig. 17 Control pulse generator circuit

2-b Reference signal generator and frequency divide circuits

A 31.468kHz signal is generated in the feedback loop formed by a crystal oscillator, emitter-follower Q409 and an amplifier stage inside the IC. A 31.468kHz pulse output is obtained from pin 9, and this is divided by 2 to form the reference signal (REF H). By dividing by 2 again, the signal for activating the burst signal polarity inverter circuit is obtained.

2-c Equalizing pulse eliminator circuit

When the synchronizing signal separated from the reproduced video signal in the V-DEM is applied to pin 11, the equalizing pulse is eliminated by operation of a mono-stable multivibrator circuit.

2-d Sampling pulse generator

Since the reproduction synchronizing signal "edge data" is not sufficiently accurate for use as a sampling pulse in the tangential servo mechanism (due to the characteristics of the synchronizing separator circuit), the sampling pulse is formed from the burst signal. A PBH is obtained by eliminating the equalizing pulse from the reproduced synchronizing signal in MMV7. MMV2 and MMV3 are triggered in sequence by this signal, and following an AND operation on the MMV3 output and the shaped burst signal, MMV1 is also triggered. The MMV1 output pulse is used for the sampling pulse. The sampling pulse and MMV3 output are then subjected to an AND operation, resulting in detection and amplification of the time difference between the 2 signals, and subsequent control of the MMV2 time constant. The reason for this is to obtain an accurate sampling pulse despite fluctuations in the burst signal zero-cross point time differences in respect to the SYNC front porch. During stop mode, the jump pulse is divided by flip-flop (Z404) and applied to pin 19 in order to switch the MMV2 time constant, thereby reducing color irregularities in the top part of the picture.

2-e V-COM

Since there are no burst signals in the equalizing pulses intervals and V synchronizing interval, the sampling pulse can't be obtained from the burst signal. So, the modified V synchronizing signal is used for obtaining the sampling pulse in these intervals. Hence, REF H is counted by Z401 and Z402 after the V synchronizing signal which is delayed about 3H by C401 and R402 has come. At the 256th count, pin 11 of Z402 is turned from high to low level, resulting in the generation of the

pulse with approximately 9H width by C402 and R405. And this pulse is applied to pin 30 of Z403 via Q403 and used to obtain the sampling pulse in this 9H interval. That pulse with 9H width is also used as switching pulse. When the Q411 FET is switched off by this pulse, the voltage corresponding to the time difference between the sampling pulse and MMV2 output is held by C418. The hold voltage controls MMV3 output pulse width via Q413 and Q414, thereby the sampling pulse is generated at the accurate time.

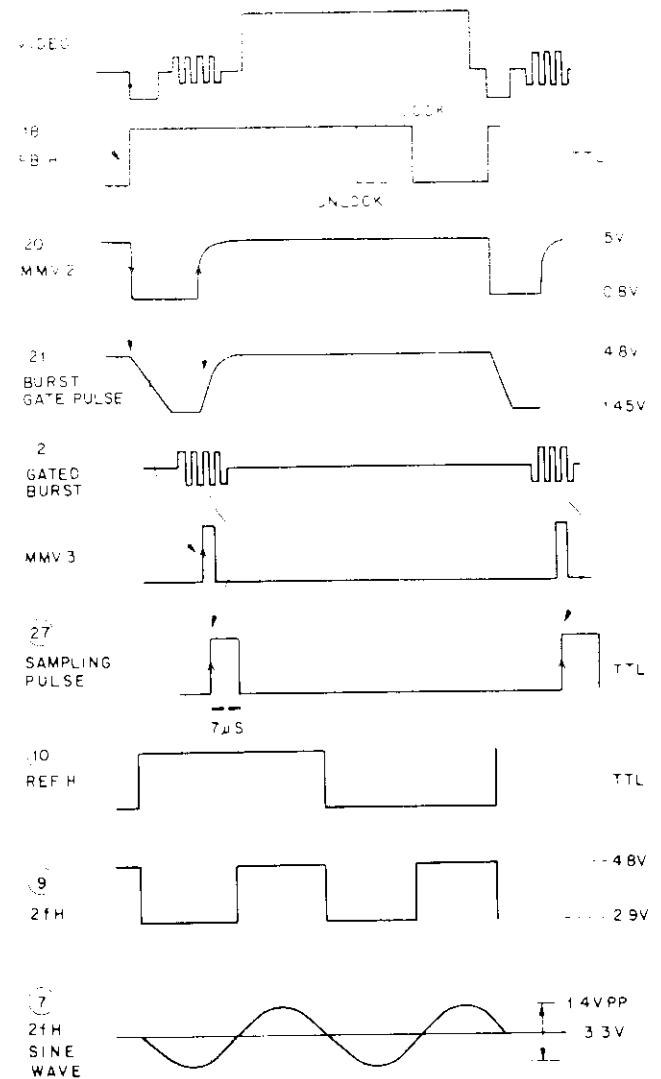

Fig. 18 Waveforms on UA5003

3. Tangential Servo Circuit

The circuits required for control of the tangential mirror are all incorporated in Z405. The major component circuits include:

- (a) an equalizer op. amp.,
- (b) lock detector circuit,
- (c) trapezoidal waveform generator,
- (d) sampling hold circuit, and
- (e) a phase and frequency detector circuit.

3-a Operation

A reset pulse is formed by input of REF H to pin 8, and the electric charge on C419 is subsequently discharged by this pulse signal. A sloping voltage is thus formed in accordance to the C419 constant charging rate determined by the R538/R438. The C419 charging operation is stopped in order to form a flat section at the sampling position as shown in Fig. 19, thereby obtaining an accurate sample/hold. The sampled voltage is held by C420, and applied to pin 28 via C421 from the Q415 FET buffer. Error is amplified by the AMP1 and AMP2 equalizer amplifier, and further amplified by AMP3 and Z407 in order to drive the tangential mirror. The rotation angle is restricted by AMP4 and diodes in order to prevent the mirror

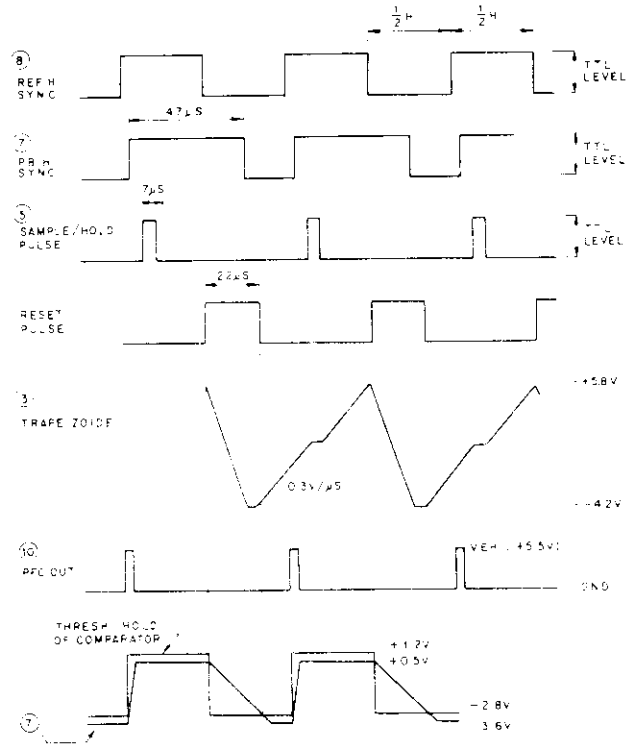

Fig. 19 Sample/hold timing chart

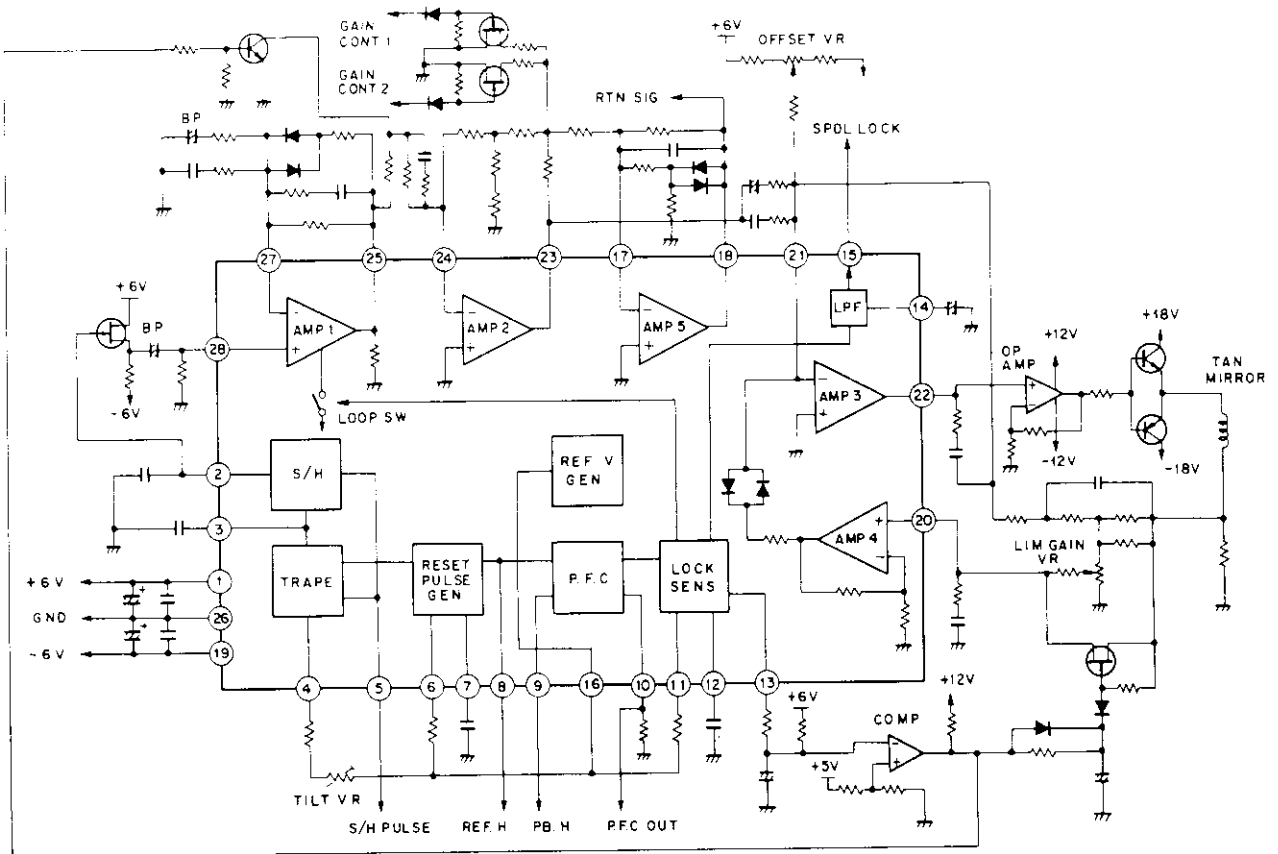

Fig. 20 Tangential servo circuit

rotation too far at maximum input level. Since the required angle of rotation in the tangential mirror increases while moving towards the outer track in CAV discs, the gain is switched in 4-step switching by the Q417/Q418 FET switch. With CLV discs, the gain is fixed. The error signal required for the spindle servo is obtained from the branch point between R154 and R152, amplified by AMP5, and mixed with the PFC output in order to control the spindle motor.

3-b Lock detector circuit

The lock detector circuit includes 2 detectors, one for detecting a phase difference of less than 31.7 μ s between REF H and PB H, and the other for detecting a difference of less than 10 μ s. The first is used to switch the tangential servo loop on and off, while the other is obtained as an output from pin 15.

3-c Mirror limiter

When using discs of considerable eccentricity, the movable range of the mirror will be initially rather wide, making lock-in difficult to attain. For this reason, the voltage from pin 13 which appear in the same timing as tangential servo lock is applied to Z408 voltage comparator, and passed

through the R529 C451 delay circuit, resulting the Q419 gate voltage is increased gradually. The width of the mirror limiter is thus widened gradually.

4. Spindle Motor Control Circuit

The circuits required for control of the spindle motor are all incorporated in Z406. The major component circuits include:

- (1) an op. amp.,
- (2) comparator, and
- (3) logic circuits.

4-a Starting

When the play key is pressed, RUN from the CONT board is switched from H to L level, resulting in S7 being turned on, and the +Vcc output being obtained from AMP2. Since the externally connected amplifier stage is a non-inverting amplifier, +20V is applied to the motor and the disc starts to rotate. Motor rpms are detected by an AC tacho-generator, and when the rpm reaches 1500, a 1.2V voltage is generated on pin 17. Since the voltage on pin 19 is set exactly to this voltage, COMP2 is inverted. The acceleration drive is then stopped, and the S6 loop switch is turned on. If the focus servo has already been locked, a COMP SYNC signal will be passed from V-DEM, resulting

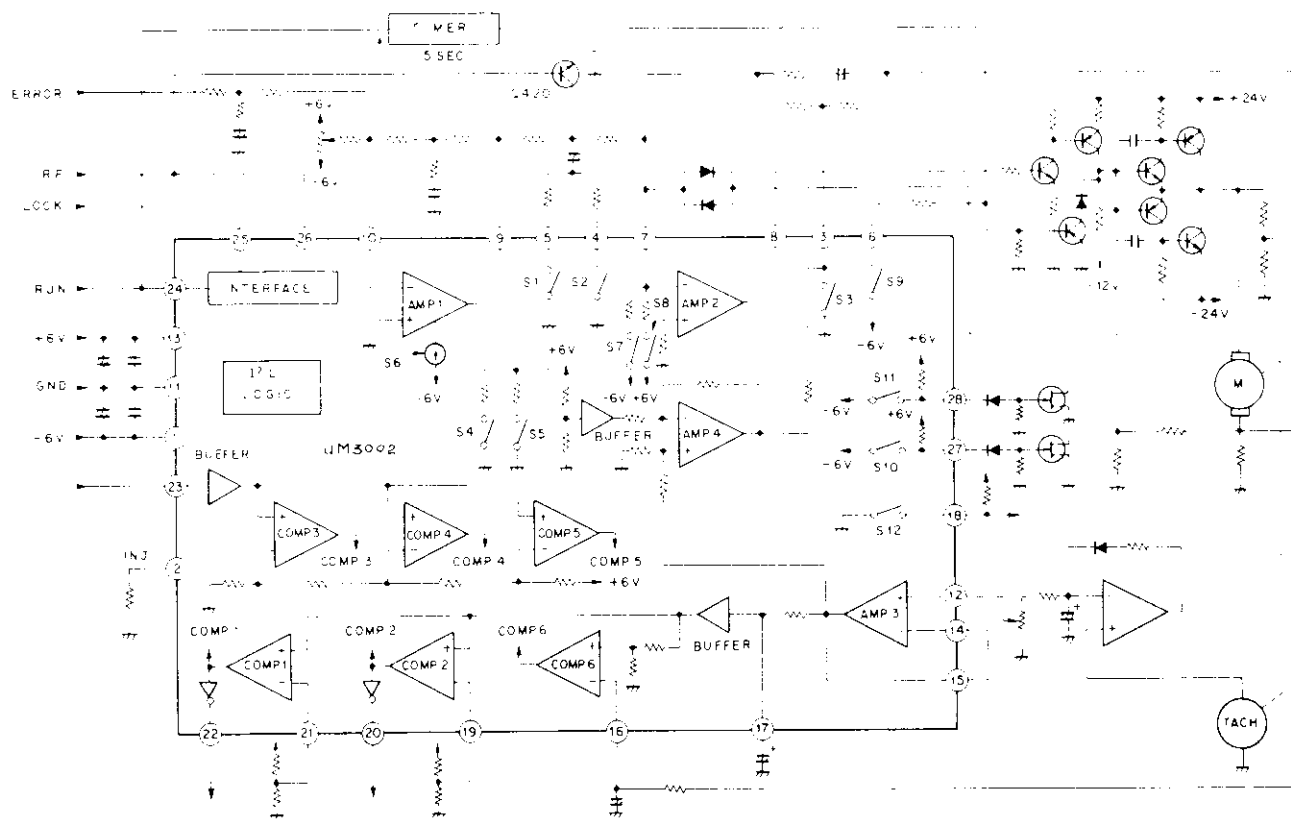

Fig. 21 Spindle motor control circuit

in activation of the Z405 PFC (phase-frequency comparator), and the generation of a pulse signal at pin 10 of Z405 in proportion to the phase difference between REF H and PB H. This pulse signal is passed through a low-pass filter and amplified by AMP1. This output is also amplified by AMP2 and used to control motor speed.

4-b Stopping

When the REJ key is pressed, RUN is switched from L to H level, resulting in S8 being turned on, and the AMP2 output being switched to $-0.5V$. This output is amplified, and by making the motor terminal voltage negative, effectively brakes the motor. Once the disc rpm drops to 360, COMP1 is inverted, resulting in pin 6 being reduced to $-V_{cc}$. Q423 is thus turned on and the brake released.

4-c Gain control

S1 and S2 are turned on or off depending on disc size and type (CLV or CAV), thereby selecting the appropriate gain. This switching status is outlined in Fig. 23.

4-d Motor servo during focus unlock mode

Since PB H is not generated if proper focus is displaced, the spindle motor will tend to speed up in runaway condition. To prevent this, motor rpms are detected by an AC tachogenerator, compared with a reference speed voltage, and the resultant error amplified by AMP4 for use in motor speed control. With CAV discs, this reference voltage is fixed, while with CLV discs it is switched in 4 steps, thereby enabling phase to be locked for a short period when the focus servo is locked.

4-e Disc size detector

The 8 in. and 12 in. disc diameters are detected by COMP6. A voltage proportional to the motor rpm is applied to one of the comparator inputs, while a voltage which detects the motor current is applied to the other, thereby ensuring that disc size is properly determined with both CAV and CLV discs alike.

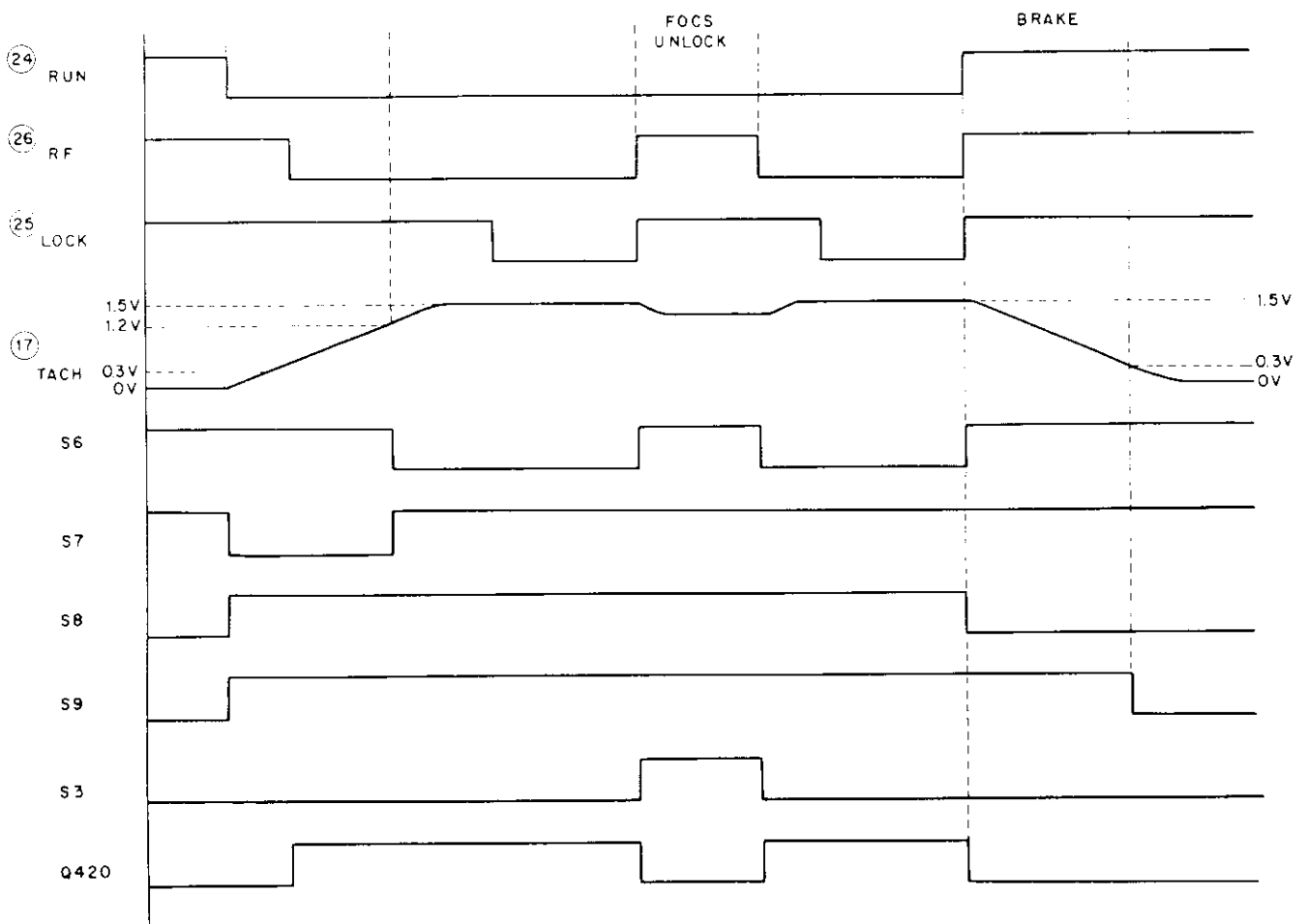

Fig. 22 UM3002 timing chart

SPINDLE MOTOR GAIN CONTROL

	12 INCH		8 INCH	
	CAV	CLV	CAV	CLV
A	OFF	OFF	OFF	OFF
B	OFF	ON	OFF	ON
C	OFF	OFF		
D	OFF	ON		

S1

	12 INCH		8 INCH	
	CAV	CLV	CAV	CLV
A	OFF	OFF	ON	ON
B	OFF	OFF	ON	ON
C	OFF	ON		
D	OFF	ON		

S2

TANGENTIAL MIRROR GAIN CONTROL

	12 INCH		8 INCH	
	CAV	CLV	CAV	CLV
A	ON	ON	ON	ON
B	OFF	ON	OFF	ON
C	ON	ON		
D	OFF	ON		

S10

	12 INCH		8 INCH	
	CAV	CLV	CAV	CLV
A	ON	ON	ON	ON
B	ON	ON	ON	ON
C	OFF	ON		
D	OFF	ON		

S11

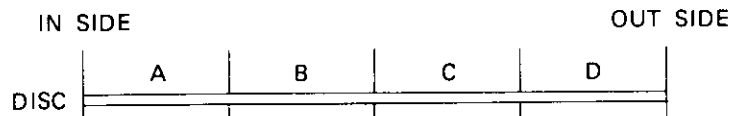

Fig. 23 UM3002 switches status

5-7 CONTROL SYSTEM

The control system for the PR-8210-A consists of the KEYC (KEYA, KEYB), IRAB, and the CONT circuit boards. The microprocessor on the CONT board controls the servo circuits and the various playback modes. This control system also monitors player operating conditions. If an abnormal condition should arise, the control system detects and corrects that condition. In cases where the condition cannot be corrected (such as faulty condition cannot be corrected (such as faulty interlocking during play mode) player operation will be halted.

The following input signals are applied to the CONT board during control operations.

- Key input signals (from KEYC and IRAB)
- Status information signals from various sections of the player.
- Video signal data (including frame no. from VDEM)
- PBH and VSYNC (from VSOP)

The CONT board in turn generates the following output signals.

- Control signals for various sections of the player (applied to VSOP)
- Indicator LED on/off signals (applied to KEYC and IRAB) used to indicate the player operating status.
- Signals used to indicate the frame no. and chapter no. in the TV screen (applied to VDEM)

A list of these input and output signals is given in Fig. 24.

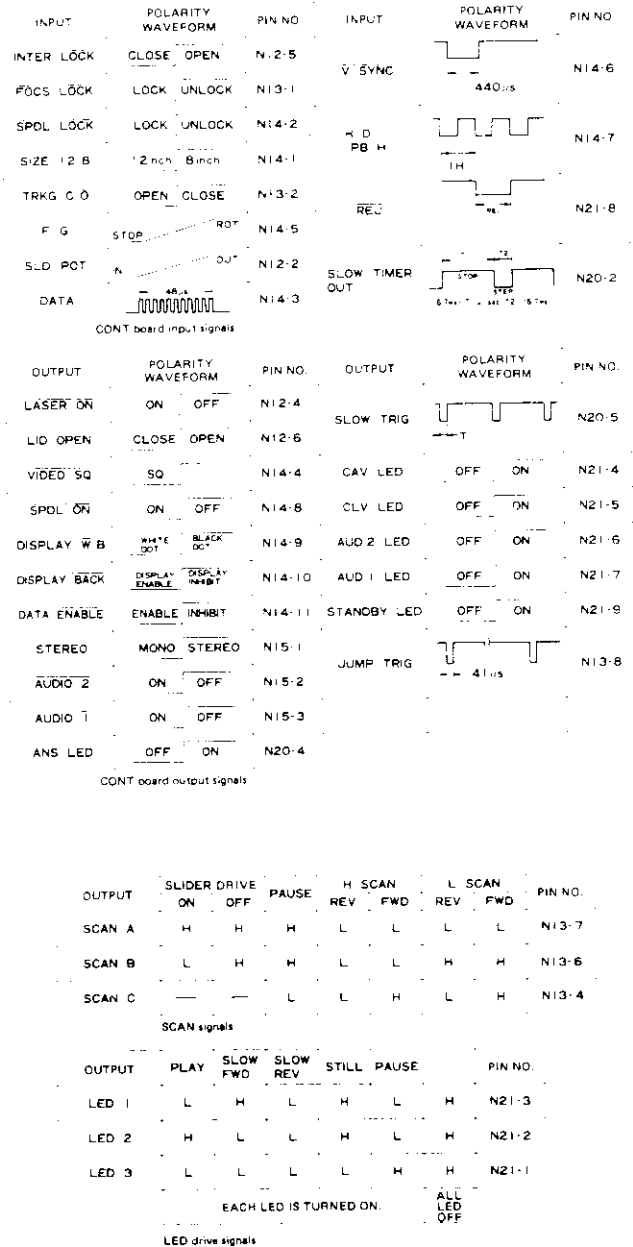
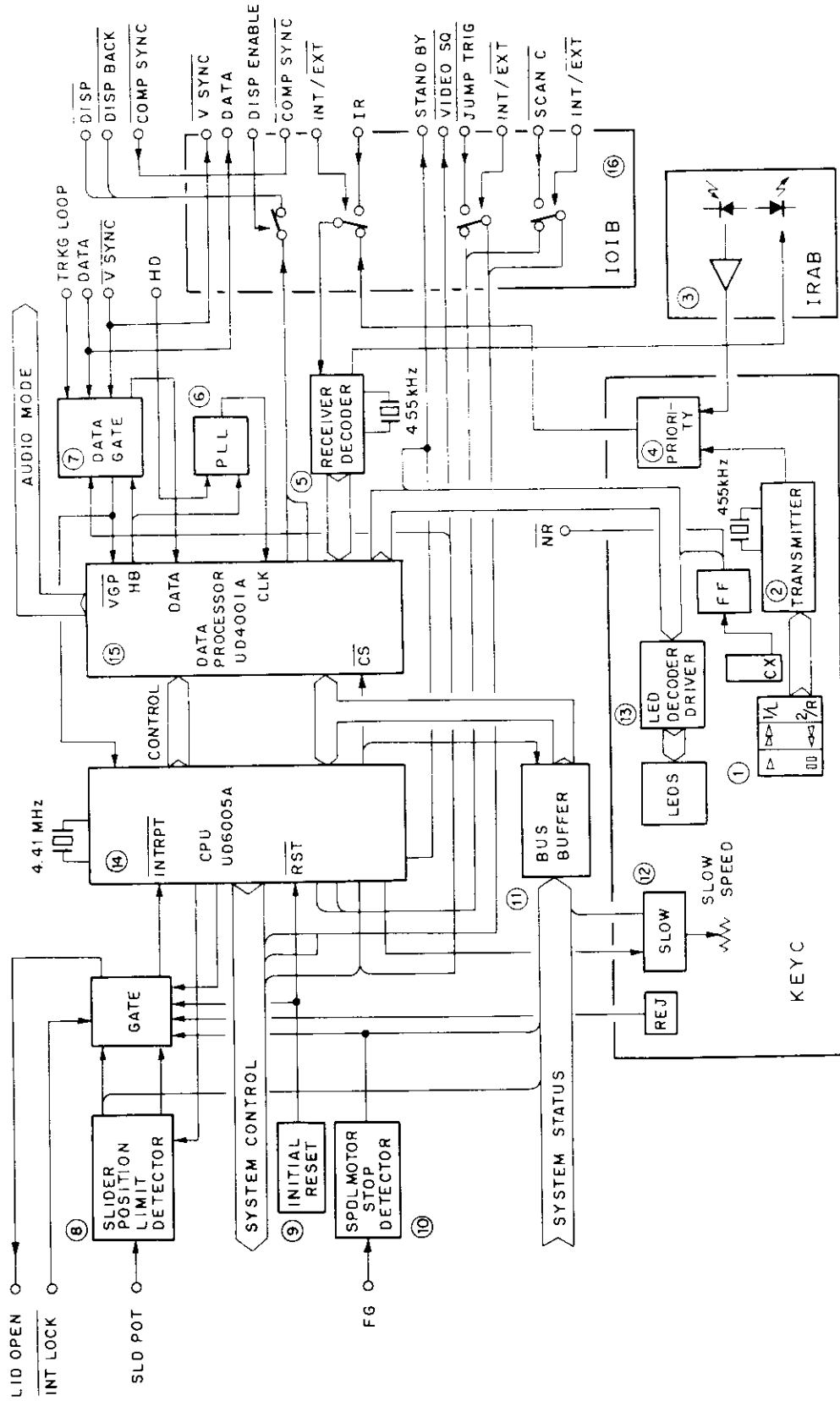

Fig. 24 CONT BOARD INPUT/OUTPUT signals.



2. Individual Block Descriptions

The way in which each part of the control system operates is described below in reference to the block diagram outlined in Fig. 25.

(1) Key Matrix

Six of the seven operation push-buttons on the front panel of the video disc player (the CX push-button being the exception) constitute a key matrix. Six separate commands can be sent to the transmitter (2) by push-button operation.

(2) Transmitter

The output from the remote control transmitter IC (M50110CP) is obtained by push-button selection of the output from the IC scan signal generator, and subsequent conversion of the returning signal into a 10-bit serial PCM encoded signal. Although this IC output signal is obtained in the form of a 10-bit PCM code amplitude modulated by the 38kHz carrier, the 38kHz component is removed by a detector circuit following the IC.

(3) IRAB

This stage receives infrared signals from the remote control section which is equipped with the same kind of transmitter IC as described in (2) above. Hence, the infrared signal from the remote control section following reception and photoelectric conversion in the IRAB photo-detector is detected, shaped, and converted into a 10-bit serial PCM encoded signal which is subsequently passed to the next stage.

(4) Front panel key priority circuit

This circuit ensures priority of the front panel push-button input signals over the remote control unit key input signals. By pushing any of the player front panel operation push-buttons, the gate is switched by utilizing the oscillator action of the IC described in (2) above.

(5) Receiver

This stage contains the remote control reception IC (M50117CP). 10-bit serial PCM encoded signals obtained by pressing the player or remote control operation push-buttons are converted to 5-bit parallel binary encoded signals before being passed on to the data processor.

(6) PLL

Consisting of a phase comparator (TC5081AP), a low-pass filter, and a discrete VCO, the PLL stage generates 3.02MHz clock signals for the data processor. The 1/192 divider circuit in the data processor generates an HB signal of the same repetition frequency as the horizontal synchronizing signal, and applies the signal to the phase comparator input. The phase comparator clock serves as the character dot reference for frame numbers etc, it being necessary for the display of this data in the TV screen to be synchronized accurately with the horizontal synchronizing signal. For this reason, this PLL stage is designed to ensure synchronization with the PB H signal from the VSOP.

(7) Data gate

Each type of data detected from the playback video signal is applied to the data gate where the vertical and horizontal synchronizing signals serve as reference signals. Only data in lines 16 and 18 is extracted and subsequently passed to the data processor.

(8) Slider position detector

The DC voltage from the slider pot is applied to two separate comparators as slider position data, this data being used to detect each inside and outside limit position.

(9) Reset control circuit

The CPU is protected against power reductions by means of a "reset control" which involves detection of drops in the VDD voltage.

(10) Spindle rotation detection

The SPDL motor FG output is integrated and then passed to a comparator as motor rotation data, thereby fulfilling one of the conditions for opening the player lid.

(11) Input buffer

This input buffer serves as the CPU extended input port buffer for storage of status information received from various parts of the player.

(12) Slow timer

The NE555 and the slow speed VR plus capacitors mounted on the KEYC circuit board operate as a MMV for slow motion speed settings.

(13) LED driver

The driver and decoder employed to operate the front panel indicator LEDs.

(14) CPU

The CPU used in this video disc player is an 8049 series NMOS IC incorporating a 2kbyte program ROM plus a 128 byte scratch-pad RAM. The operating clock frequency is 4.41MHz. The CPU is connected to the data processor via an 8-bit data bus. Control signals are transferred between this IC and the servo system in accordance with player operating mode. When a control signal from the 16-bit output port is passed to the servo system according to the prescribed timing, a corresponding response is detected. The CPU also performs arithmetic operations during search mode on the basis of frame data and address data sent from the data processor.

(15) Data processor

This IC is a 42-pin NMOS IC with an operating clock frequency of 3.02MHz. The four major functions are listed below.

1. Decoding of the Philips code extracted from the playback video signal.
2. Storage of the above data.
3. Character display control.
4. 8-bit x 2 port processing.

The Philips code decoder catches the leading edge of the 500kHz Philips code by 3.02MHz scanning and subsequently detects the frame no., chapter no., time no., and the various mode flags. This data is then passed on to the CPU.

The data storage RAM stores data from the reader and designated data from the CPU in 20 byte units.

The display output stage generates outputs at the prescribed position synchronized by the horizontal synchronizing signal in accordance with CPU directions and with 3.02MHz as the display clock.

(16) IOIB

The IOIB is the interface between the PR-8210-A and external controller. Signals are sent and received through the 24-pins connector on the rear terminal board. The following system information signals are output from the PR-8210-A.

- COMP SYNC (#4)
Sync signal separated from the video signal
- DATA (#2)
Frame data separated from the video signal
- V SYNC (#1)
Vertical sync signal separated from the COMP SYNC
- VIDEO SQ (#3)
Command that prohibits the video signal from being sent to the TV set
- STAND BY (#5)
Command that lights the stand-by indicator

The following signals are input from the external controller together with each INT/EXT (the internal and external control switching signal).

- REMOTE CONT (#10)
The serial code signal for the various operation commands
- JUMP TRIGGER (#12)
Command that activates track jump
- SCAN C (#6)
Command that determines the direction of track jump and scan

DISPLAY (#8) is the command that prohibits sending the display characters to the TV screen. Pins of #13-#24 are connected to ground.

3. Software

The computer software employed in the control of the video disc player includes two monitor programs called the Begin-End monitor and the Playback monitor. (See Fig. 26)

(1) Begin-End monitor (Fig. 27)

- Used in monitoring player operations and status up until a picture is obtained in the TV screen after the power has been switched on. This monitor is also involved in control operations if the need arises.
- When the reject button is pressed during play mode, and the user removes the disc from the player, this monitor program also ensures that these steps are performed safely.

(2) Playback monitor (Fig. 28)

- Used in player control to ensure proper playback mode according to the pressed operation push-button.
- Also used in player control to support playback control where normal playback is not possible.

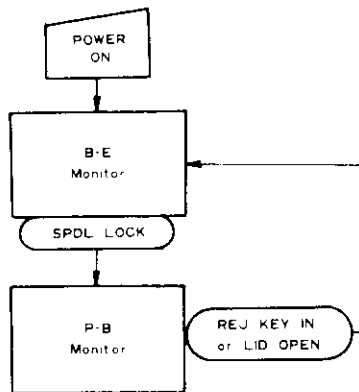

Fig. 26 B-E monitor and P-B monitor

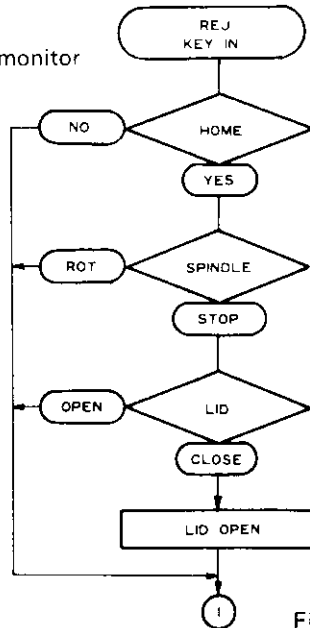
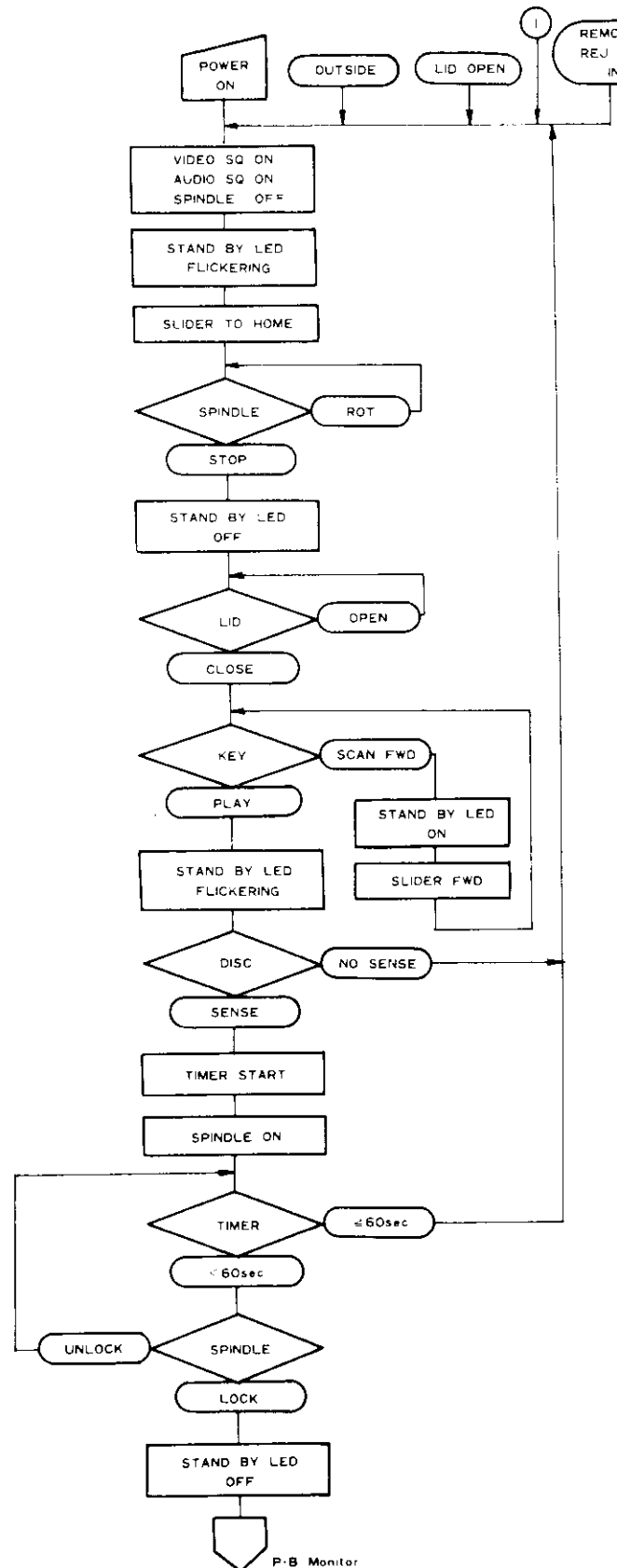

Fig. 27 Flow chart of B-E monitor



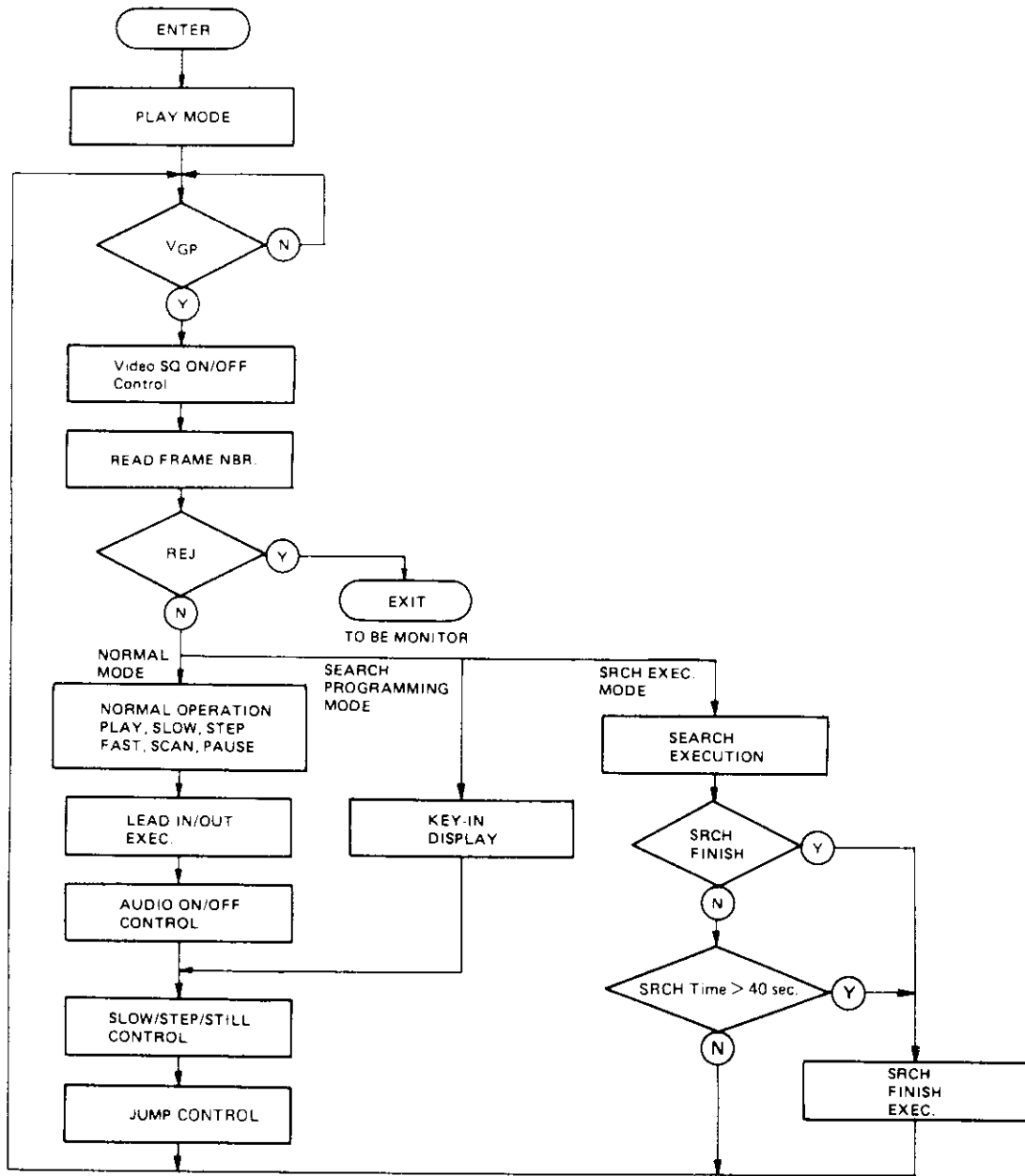

Fig. 28 Flow chart of P-B monitor

Control operation in each playback mode

Control operations during STILL/STEP and FAST X3 modes are shown in the Fig. 29. The left side of the illustrates which track the pick-up is

positioned on, and the right side gives the timing sequence of jumps triggering the changes of the video field reproduced on the TV screen.

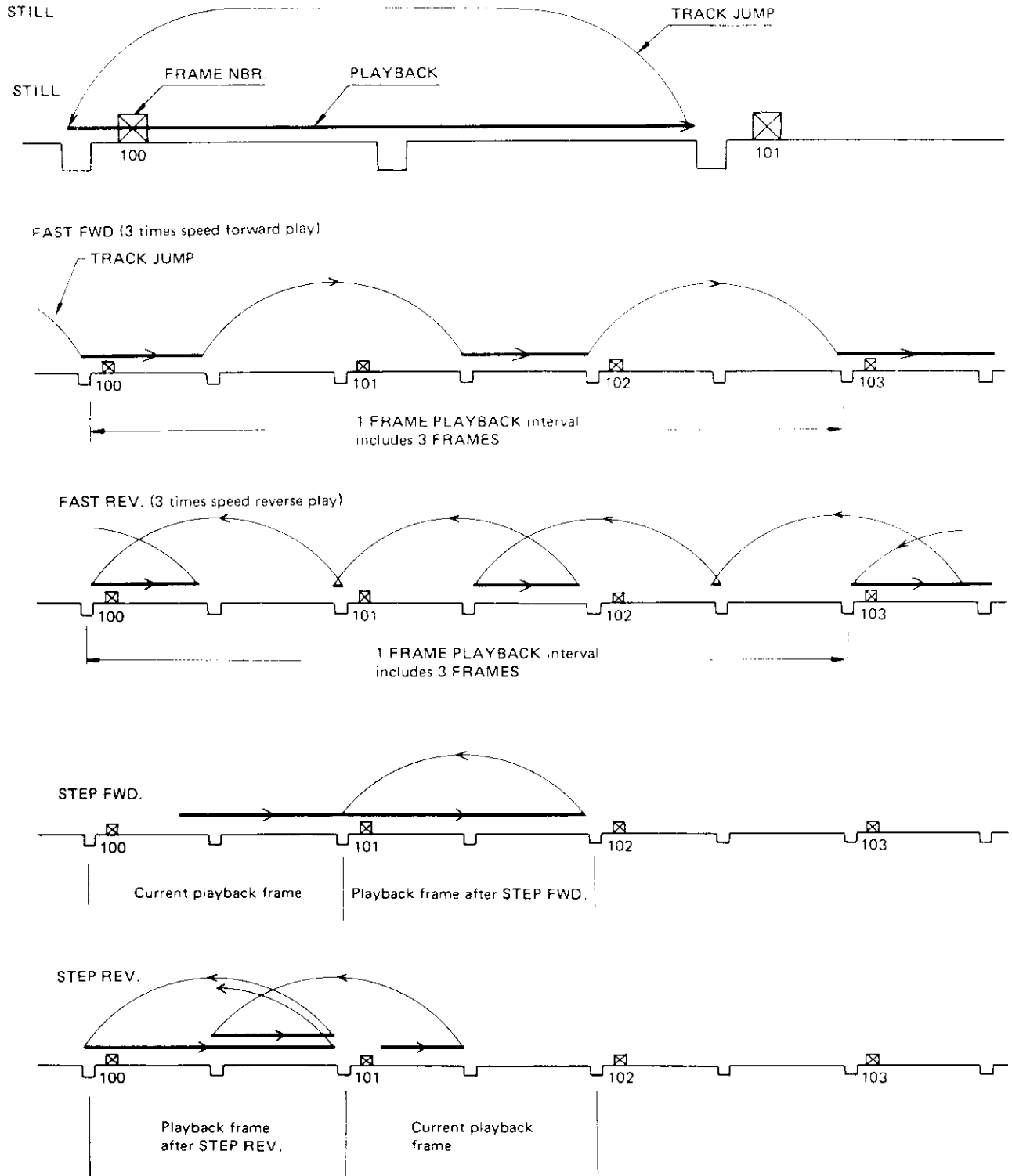
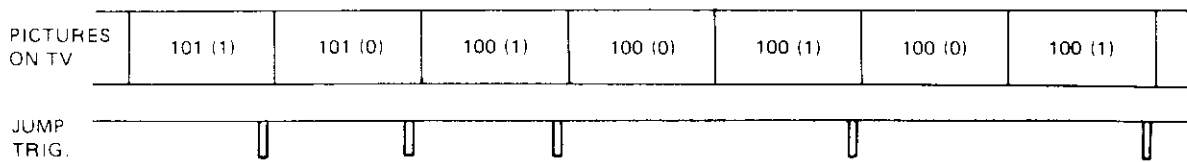
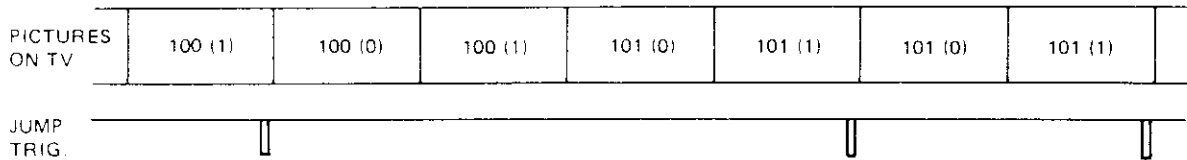
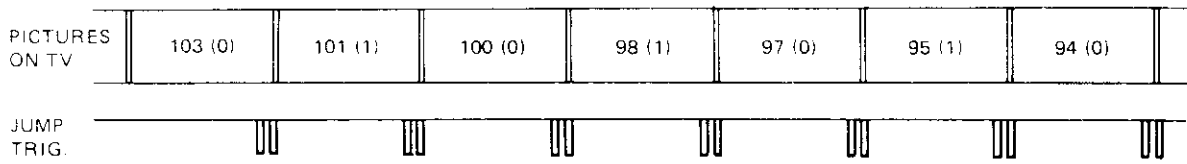
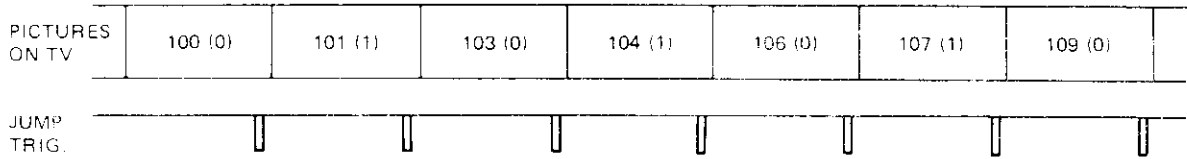
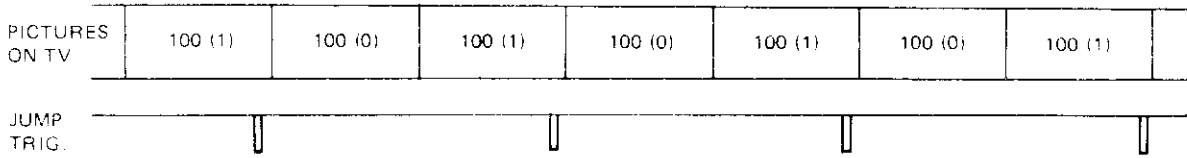

Fig. 29



Search operation

The fig. 30 shows the method of search operations, and with the pick-up positioned on frame number 2,000, uses the search procedure to frame number 1,000 as an example.

Example: Sequence followed during search from present position ≈2,000 to ≈1,000

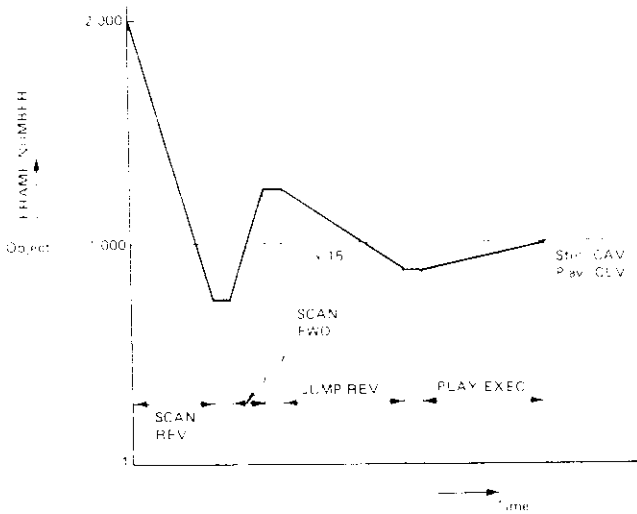

Fig. 30 An example of search operation

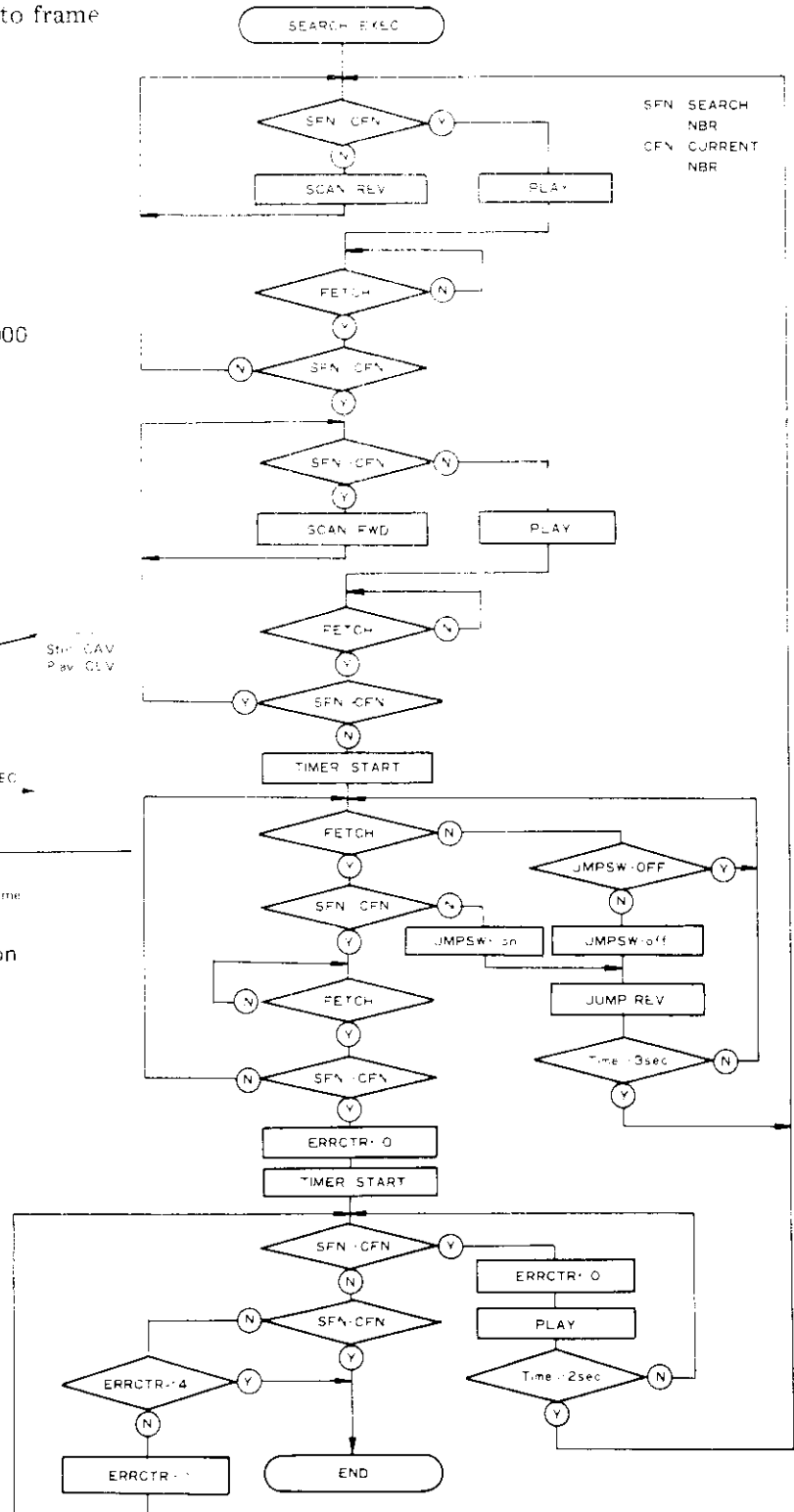
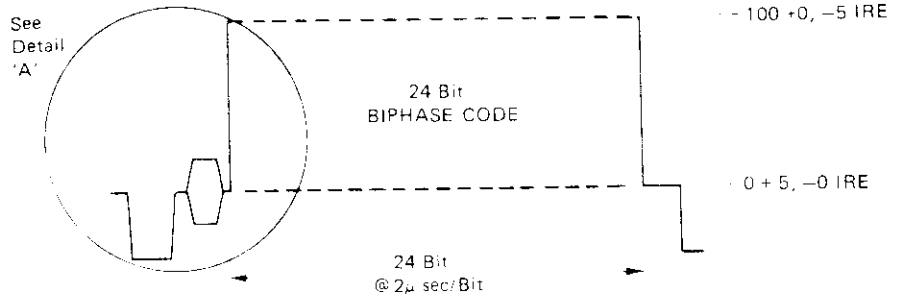

Fig. 31 Flow chart of search operation

1. Positive transition in center of bit cell represents logical "1"'s. Negative transitions in the center of bit cell represents logical "0"'s.
2. Rise and fall times = 225 ± 25 nsec. (10 - 90%)



Bits value	Hexadecimal
0 0 0 0	0
0 0 0 1	1
0 0 1 0	2
0 0 1 1	3
0 1 0 0	4
0 1 0 1	5
0 1 1 0	6
0 1 1 1	7
1 0 0 0	8
1 0 0 1	9
1 0 1 0	A
1 0 1 1	B
1 1 0 0	C
1 1 0 1	D
1 1 1 0	E
1 1 1 1	F

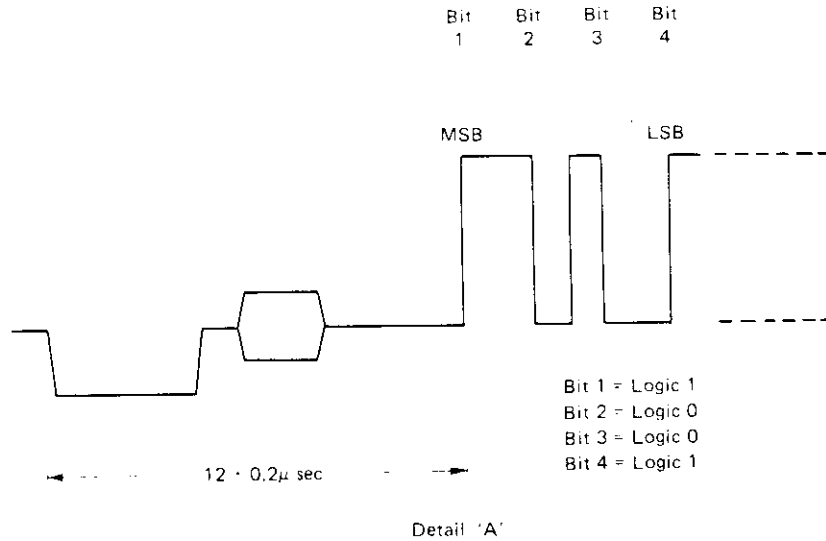

Fig. 32 Specification of the Philips code signal specification

Philips Code Specification

ITEMS	CODE	LINES	REMARKS
LEAD-IN	88FFFF	17H, 18H 280H, 281H	to indicate where the tracks are starting
LEAD-OUT	80EEEE	17H, 18H 280H, 281H	to follow immediately after the end of the active program
FRAME NUMBER (CAV)	$FX_1X_2X_3X_4X_5$	17H, 18H	$1 \leq X_1X_2X_3X_4X_5 \leq 79,999$
PICTURE STOP	82CFFF	279H, 280H	
CHAPTER NUMBER	$8X_1X_2DDD$	281H	$1 \leq X_1X_2 \leq 79$
CONSTANT LINEAR VELOCITY (CLV)	87FFFF	280H	
PROGRAM TIME NUMBER (CLV)	$FX_1DDX_2X_3$	17H, 18H	X_1 indicates the hours X_2, X_3 indicates the minutes

5-8 SERIAL CODE

The PR-8210-A can be controlled by the front panel keys, remote control unit or external controller. The commands and data from these sources are all encoded into a serial code of the same format and sent to the CONT board. This format is shown in fig. 33.

The format is a continuous pattern beginning with the fixed code "0", "0", "1" followed by D0, D1, D2, D3, and D4 to indicate the contents and ending with the fixed code "0", "0". "0" has the LOW interval width of 1.05 msec. and "1" has of 2.11 msec. The relationship between the D0-D4 codes and the commands and data is shown in the table.

TABLE

CODE					CODE NAME
D0	D1	D2	D3	D4	
0	0	0	0	1	x3 PLAY FORWARD
0	0	0	1	0	SCAN FORWARD
0	0	0	1	1	SLOW FORWARD
0	0	1	0	0	STEP FORWARD
0	0	1	0	1	PLAY
0	0	1	1	0	x3 PLAY REVERSE
0	0	1	1	1	SCAN REVERSE
0	1	0	0	0	SLOW REVERSE
0	1	0	0	1	STEP REVERSE
0	1	0	1	0	PAUSE
0	1	0	1	1	SEARCH
0	1	1	0	0	CHAPTER
0	1	1	0	1	AUDIO 2/R
0	1	1	1	0	AUDIO 1/L
0	1	1	1	1	REJECT
1	0	0	0	0	0 (Numeral)
1	0	0	0	1	1
1	0	0	1	0	2
1	0	0	1	1	3
1	0	1	0	0	4
1	0	1	0	1	5
1	0	1	1	0	6
1	0	1	1	1	7
1	1	0	0	0	8
1	1	0	0	1	9
1	1	0	1	0	FRAME

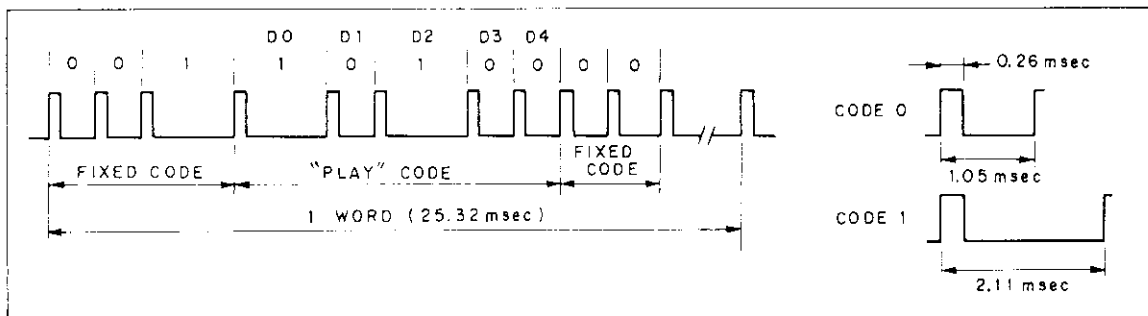

Fig. 33 Format of serial coded data.

5-9 LSPS

Voltage vs. current characteristic of the laser tube is analogous to that of a voltage regulator like thyatron. An ignition voltage of 7 to 9kV must be applied between its anode and cathode to ionize the Neon gas filled in the laser tube.

Once the laser has started to light, less voltage is required to maintain the lighting compared with igniting term. And the voltage between the anode and the cathode is settled to a constant voltage of 1,150Vdc. It doesn't depend on the value of current flow.

All Laser Power Supply circuit except laser tube and ballast resistor is concentrated on the LSPS board (VWR-011). Voltage multiplying rectifier which has been employed in PR-7820 and VP-1000 is not employed in this model. Instead of that, an ignition transformer is adopted to obtain the ignition voltage. Both this transformer and a secondary voltage doubler are enclosed in a case with resin mold, and mounted on LSPS board as IG block.

In this ignition form, IG block is only activated until the laser starts lighting. In the player stand-by term as the laser-lighting is not necessary and in the lid opening term as the laser should not be lighting, it is easy to turn the laser off by electrical controlling of the LSPS. Therefore, the laser tube is prolonged its life, also a beam shutter mechanism becomes unnecessary.

Laser tube and LSPS circuit are shown in Fig. 37.

When the PLAY key is depressed after the power is turned on, $\overline{\text{LASER ON}}$ signal is applied to pin 12 of the LSPS from CONT board. It turns the output of the inverter consist of Q1 to "high", therefore the darlington-connected Q4, Q5 are turned on. Consequently, the multi-vibrator consist of Q2, Q4, Q5, D5, D6, R14, R17, C9 and C10 starts to oscillate. The oscillation frequency is concerned by the time constant of R14/C9 and R16/C10, and is about 20kHz. The output of the multi-vibrator passes through the darlington-connected Q6, Q7, and drives the primary winding of the ignition transformer. DC voltage of around 8 to 10kV (peak value) appears on the output of secondary voltage doubler, and is impressed to the anode of the laser tube.

On the other hand, around 2,100Vdc appears on the output of the voltage doubler with 775Vac inputs. That voltage is varied by the line voltage. Q10 is turned on by $\overline{\text{LASER ON}}$ signal, then discharge current is ready to flow. On the order of 3ms or less while ignition voltage is impressed, the laser tube starts lighting, and the discharge current

flows. Due to this, Q9 is reverse-biased by the voltage-drop on R31. Q3 is turned on, and oscillation of the multi-vibrator is stopped. Accordingly, the operation of IG block is stopped.

At the same time, the discharge current is stabilized to 5mA by Q10. C7, C8, R7 connected in series between collector and emitter of Q10 operate for reducing the ripple on the discharge current and the surge voltages. R1 to R6 connected in parallel among each C1 to C6 of the voltage doubler equalize the voltage applied on each capacitor, and prevent reverse-charge for those by the discharge current when the power is turned off.

When the laser doesn't start lighting notwithstanding impression of ignition voltage by deterioration of the laser tube, Q9 is turned off by the output of the level detector consist of D7, D8, C11, C12, Q8, etc. And the oscillation of the multi-vibrator is stopped. Q9 is turned on again on the order of 1 sec or less, the oscillation of the multi-vibrator will re-start, and the operation of the igniting will be repeated.

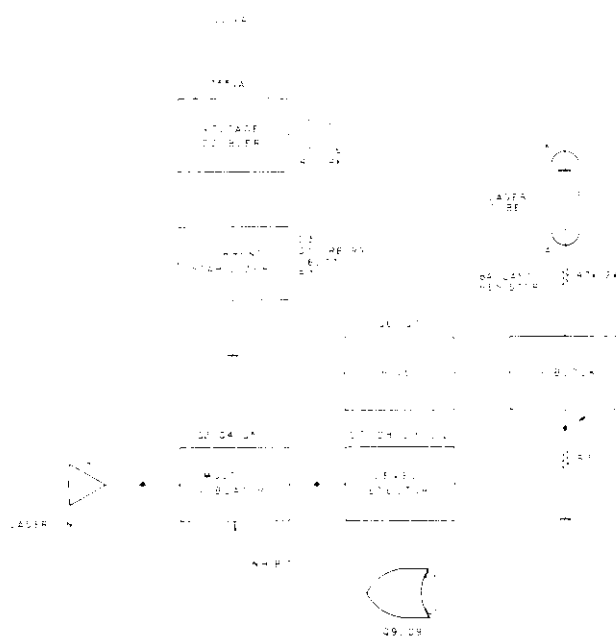

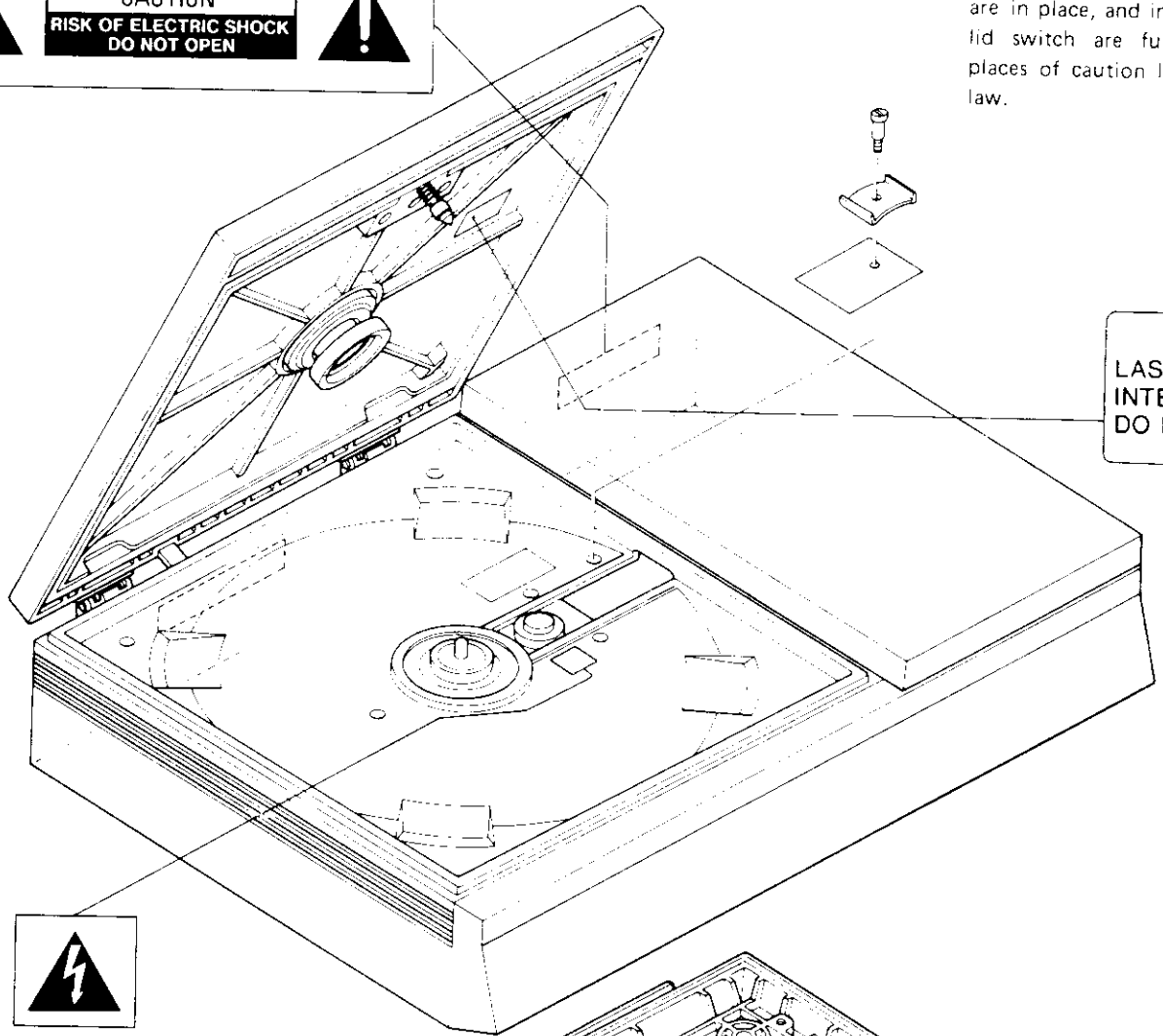

Fig. 37 LSPS block diagram

6. SAFETY CHECK

 **CAUTION**
RISK OF ELECTRIC SHOCK
DO NOT OPEN 

Before returning this
make sure all shields,
are in place, and inter
lid switch are funct
places of caution label
law.



LASEP
INTER
DO NO

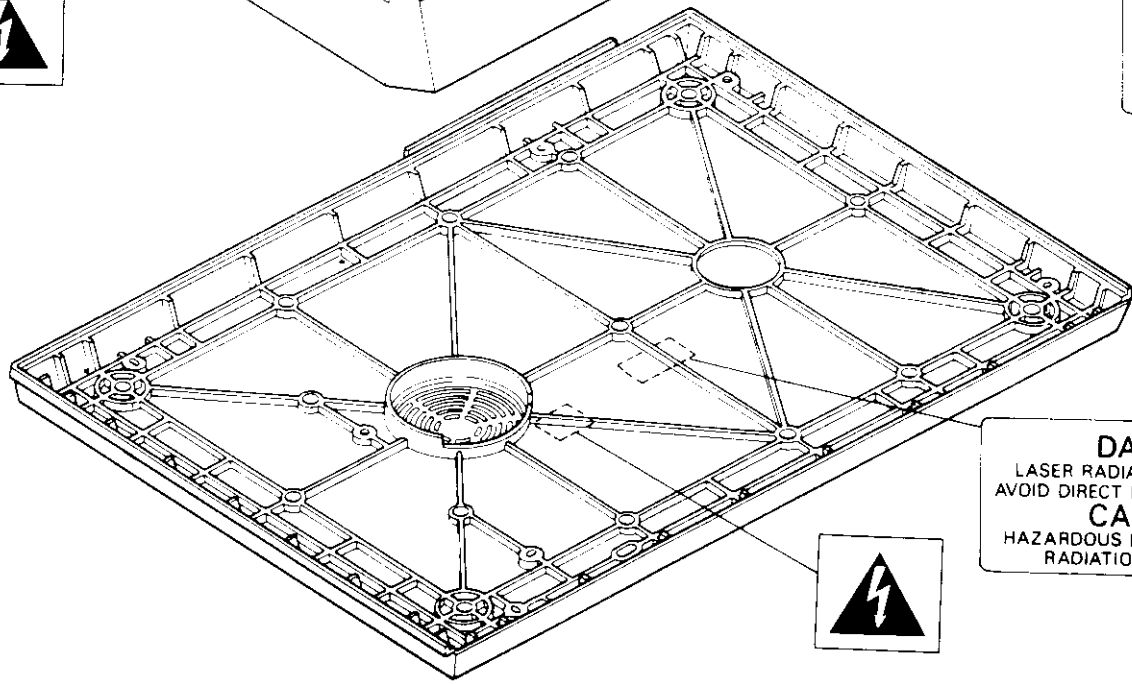

DAM
LASER RADIAT
AVOID DIRECT EX
CAU
HAZARDOUS EL
RADIATION

4

5

6

NOTE:

ing this player to the customer,
shields, barriers, covers, and labels
and inter-lock system of the lid, and
e functioning properly. Attaching
ion labels are based on the federal

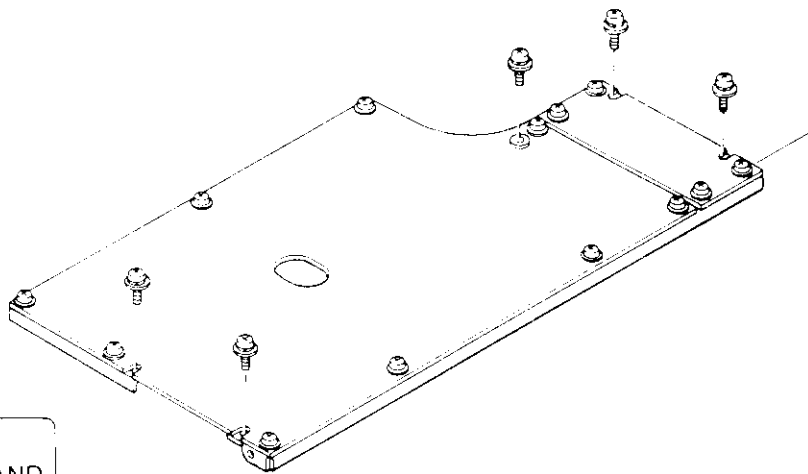

A

CAUTION
LASER LIGHT WHEN OPEN AND
INTERLOCK FAILED.
DO NOT STARE INTO BEAM.
VRW-107

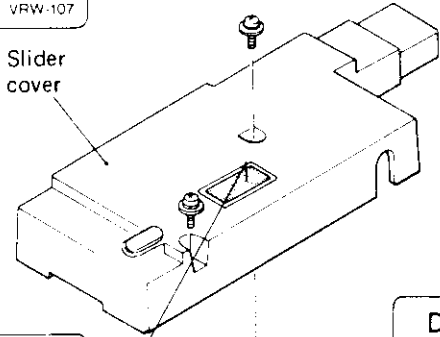

Slider cover

CAUTION
FOR CONTINUED PROTECTION
AGAINST FIRE HAZARD, RE-
PLACEMENT FUSES SHOULD
BE OF SAME TYPE AND
RATINGS ONLY VRW-021

B

DANGER VRW-095
LASER RADIATION WHEN OPEN
AVOID DIRECT EXPOSURE TO BEAM
CAUTION
HAZARDOUS ELECTROMAGNETIC
RADIATION WHEN OPEN

DANGER
HIGH VOLTAGE
VRW-085

High voltage cover

CAUTION
FOR CONTINUED PROTECTION
AGAINST FIRE HAZARD, RE-
PLACEMENT FUSES SHOULD
BE OF SAME TYPE AND
RATINGS ONLY VRW-021

C

DANGER VRW-095
LASER RADIATION WHEN OPEN
AVOID DIRECT EXPOSURE TO BEAM
CAUTION
HAZARDOUS ELECTROMAGNETIC
RADIATION WHEN OPEN

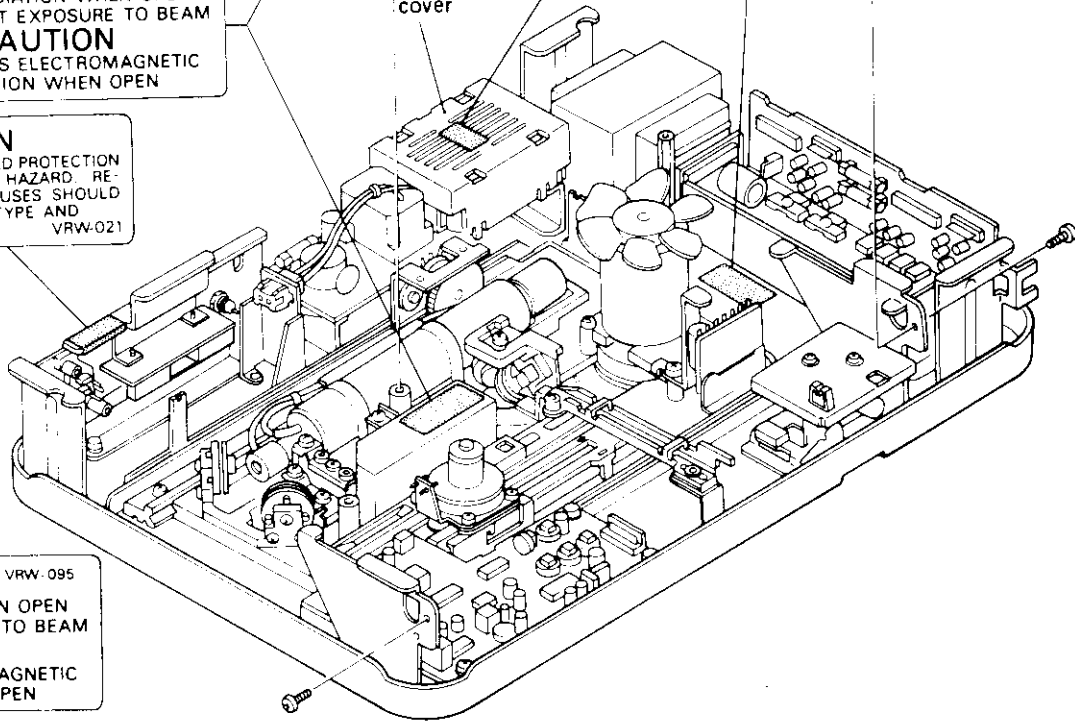

D

4

5

6

7. MECHANICAL ADJUSTMENTS

7.1 SLIDER DRIVE MECHANISM

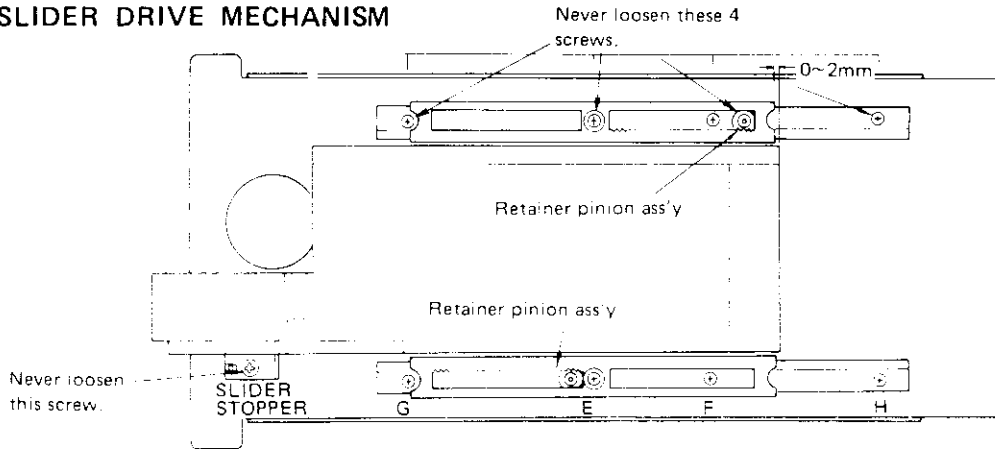

Retainer positioning

- (1) While pressing the slider against the slider stopper, posit the right edge of the both retainer to 1—2mm left of the right end of the slider.
- (2) Apply "screw lock" to the threads of the retainer pinion ass'y, and attach both retainer pinion ass'y as illustrated in the drawing.

Rail fixing

- (1) Slide the slider about in the middle of the rail.
- (2) Make sure 4 retaining screws (E, F, G and H marked) holding the underside rail in the drawing are loosely attached.
- (3) With pressing the middle of the underside rail in the drawing against the slider, firmly tighten the 4 screws in sequence E through H.
- (4) After the screws are tight, move the slider back and forth and check for smoothness of the operation.
- (5) Make sure there is no gap between the slider and rails.
- (6) Put a drop of "screw lock" on each of the 4 screws.

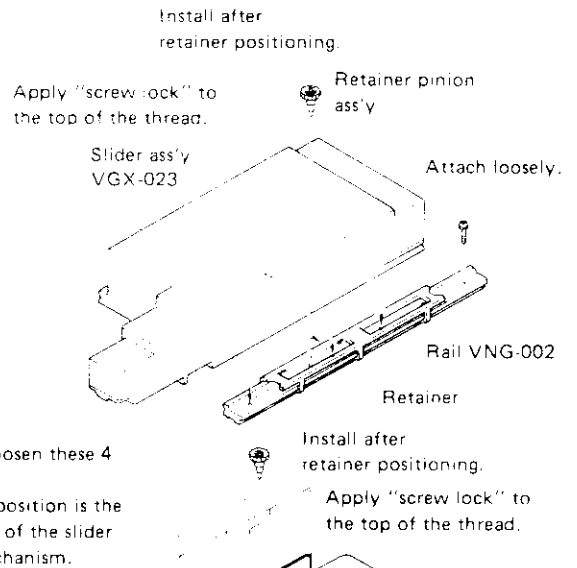

Installing directions of each roller is as described below.
Never install in different direction.

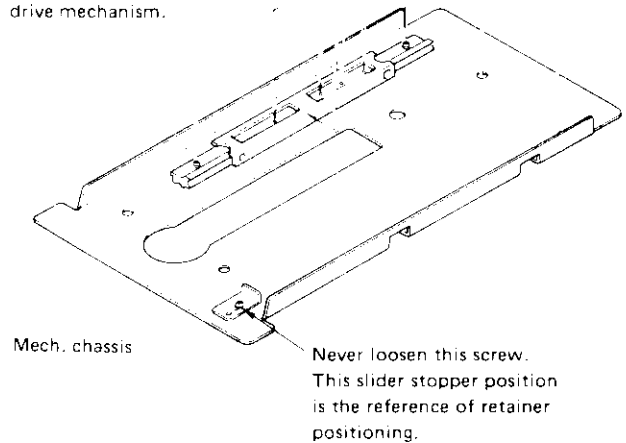
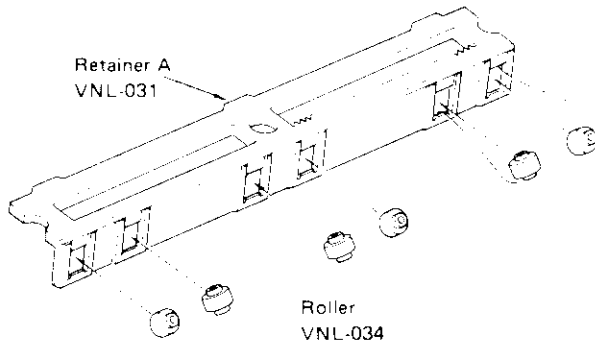

7.2 POSITIONING OF POTENTIOMETER PINION GEAR

Pinion gear positioning

With lightly pressing the slider against the slider stopper, adjust the mark of pinion just above by idling the pinion gear.

Pinion gear lock

After the pinion positioning, rotate the socket set screw clock-wise direction until the end of the screw touches lightly to the potentiometer holder, next screw back one full rotation, then apply screw lock around the screw.

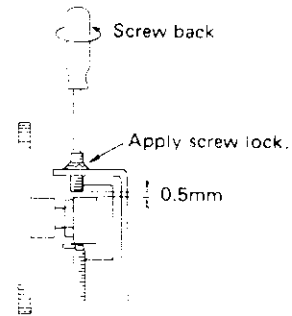
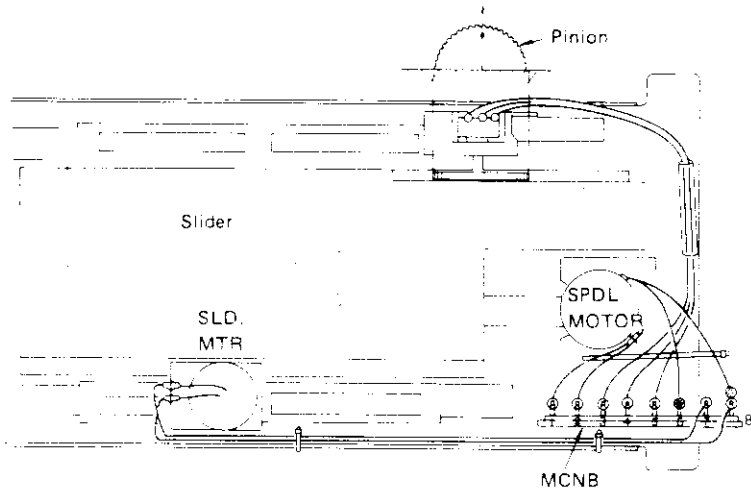

7.3 SPINDLE MOTOR HEIGHT

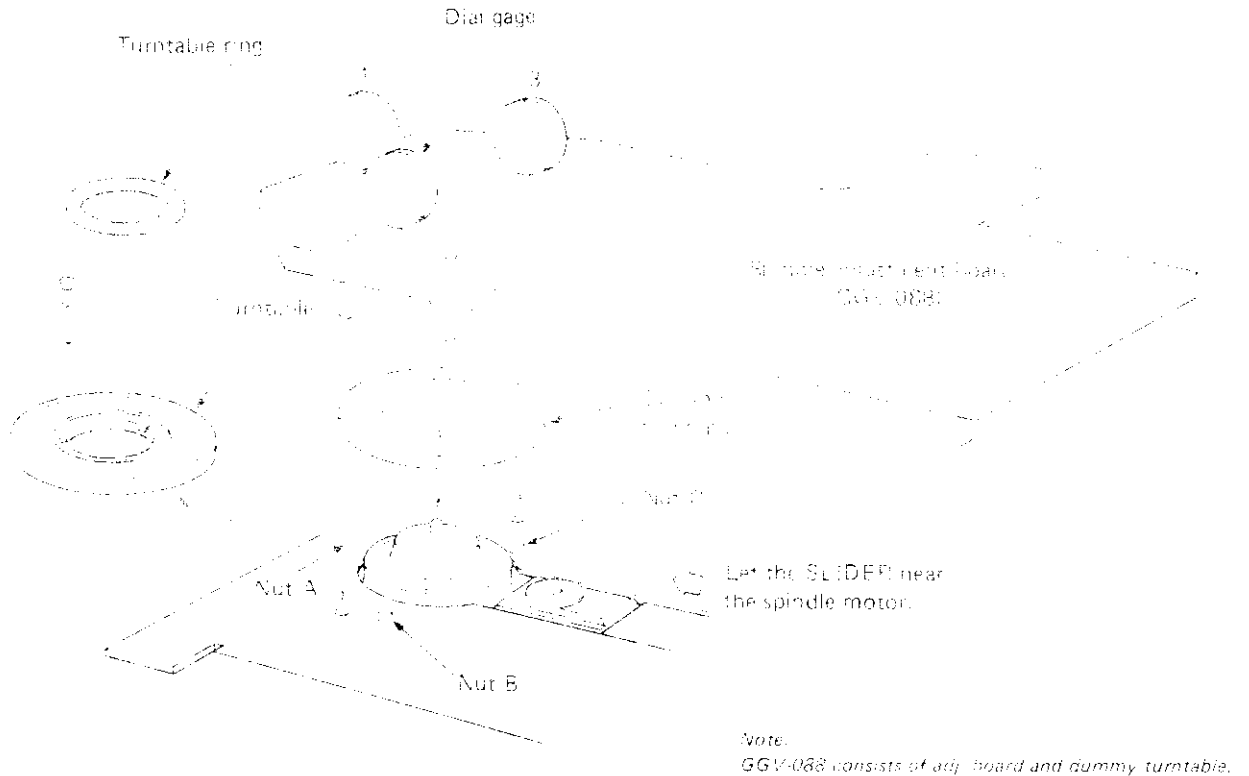

ADJUSTMENT PROCESS

- 1) Rotate an outer dial of gages so that a pointer reads - 0.1 when pin-probe is freed.
- 2) Remove an under-housing, a lid, a turntable, a top-housing.
- 3) Set the adjustment board as illustrated.
- 4) Rotate nut C so that a pointer of gage 3 reads 2.55.
- 5) Rotate nut B so that a pointer of gage 2 reads 2.55.
- 6) Rotate nut A so that a pointer of gage 1 reads 2.50.
- 7) Repeat step 4) thru 6) to obtain above readings.
- 8) Tighten lock screws and verify the readings satisfy the followings.
 - Gage 1: 2.45±0.05 (mm)
 - Gage 2, 3: 2.50±0.05 (mm)
 Tightening lock screw causes gage-reading to lower approx. 0.05 mm.
- 9) Apply lock-tite around lock screws.

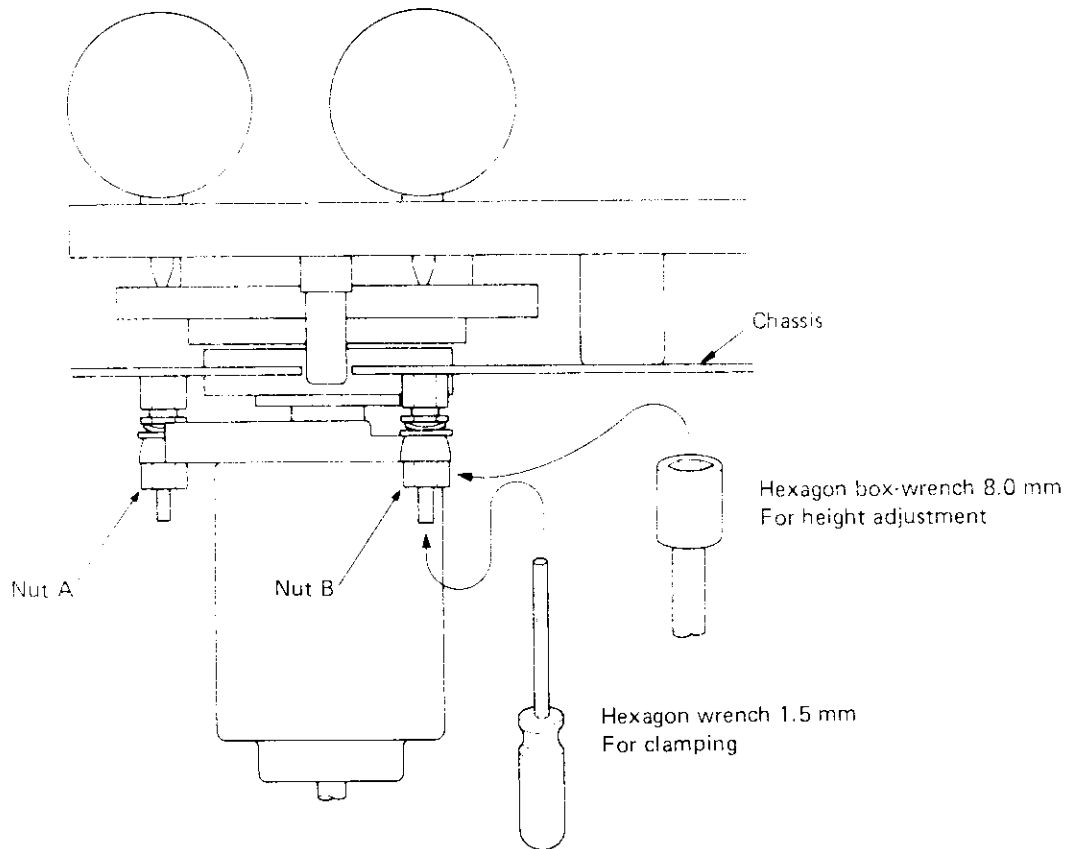

READING

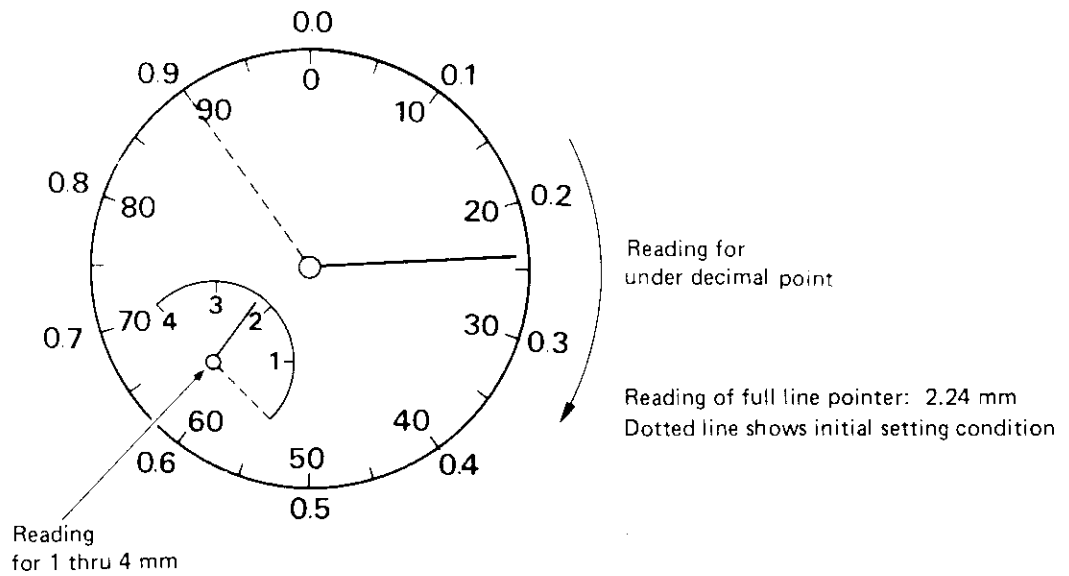

8. SLIDER ASSEMBLY AND ALIGNMENTS

All parts replacement and optical axis adjustments must be performed with the slider detached from the mech. chassis.

Prior to the slider assembly and alignment, detach the following parts from the slider base.

- Slider cover
- Shield cover
- Racks
- Laser tube
- 1st fixed mirror
- 2nd fixed mirror
- Grating
- DG lens
- 1/4 wave plate

Necessary jigs and tools

- Slider stand
- First optical axis adjustment jig (First fixed mirror adjustment)
- Power meter (Laser power measurement)

- Second optical axis adjustment jig (Second fixed mirror adjustment)
- Polarization adjustment jig (Polarization adjustment)
- Vertical jig (Tracking ass'y adjustment)
- Tracking adjustment driver A (Tracking ass'y adjustment)
- Tracking adjustment driver B (Tracking ass'y adjustment)
- Grating adjustment driver
- Grating adjustment driver 1
- Grating adjustment driver 2
- Static jig
- Static jig Stand A
- Moveable reflecting mirror
- Amp. jig
- Position sensor jig (DG lens adjustment)
- Laser power supply jig (ILPS)
- Dual trace oscilloscope
- Audio signal generator (Tracking ass'y aging)
- Rotation jig

1. Laser tube preparation

Ballast resistor preparation



Vinyl tube preparation

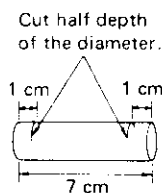

Place the resistor in the middle of the insulator tube.

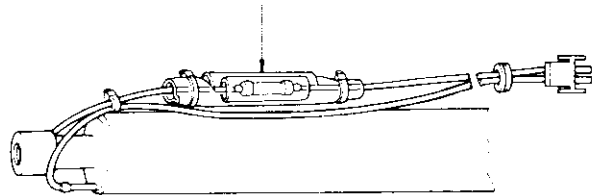

Round off the solder points.

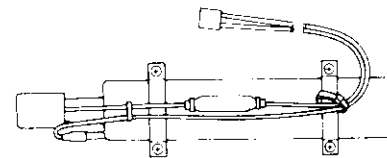
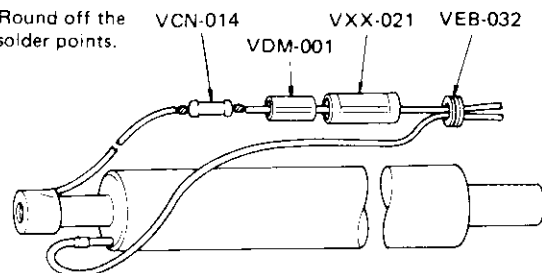

Bind the high voltage wires and the holder lightly.

2. Assembling laser tube onto the slider base

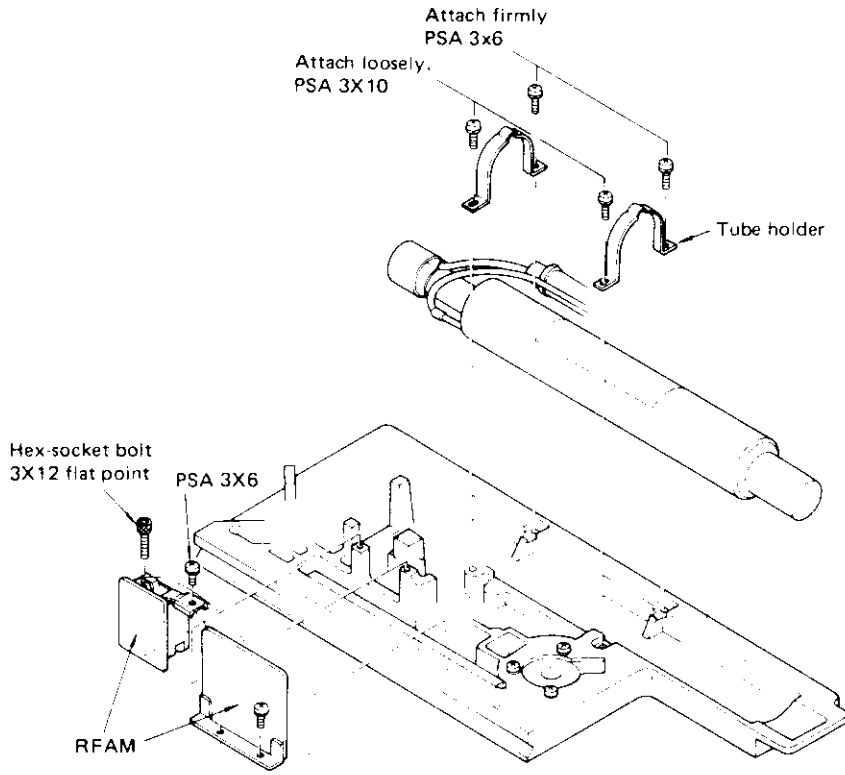

3. Polarization adjustment

- (1) Place the slider on the rotation jig and lock it down.
- (2) Set the pick-up of polarization adjustment jig in place.
- (3) Connect the laser tube to laser power supply, turn the power on and light up the laser.

- (4) Rotate the laser tube to the point where the powermeter reading is lowest and lock the laser tube by fixing screws down.

NOTE:
Make sure the laser tube can't be rotated after it is locked down. After installation, recheck the polarization adjustment.

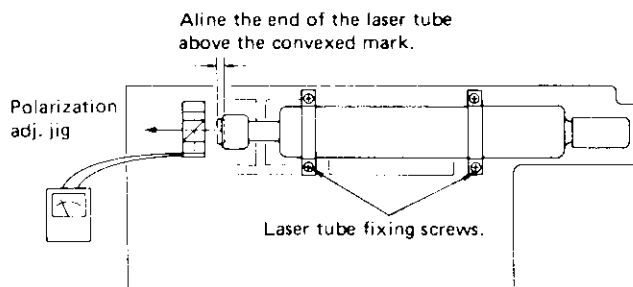

4. First fixed mirror adjustment

- (1) Attach the fixed mirror.
- (2) Set up the first optical axis adj. jig.
- (3) Adjust the hex. socket set screws (refer to the illustration below) until the beam passes thru the pin-hole.

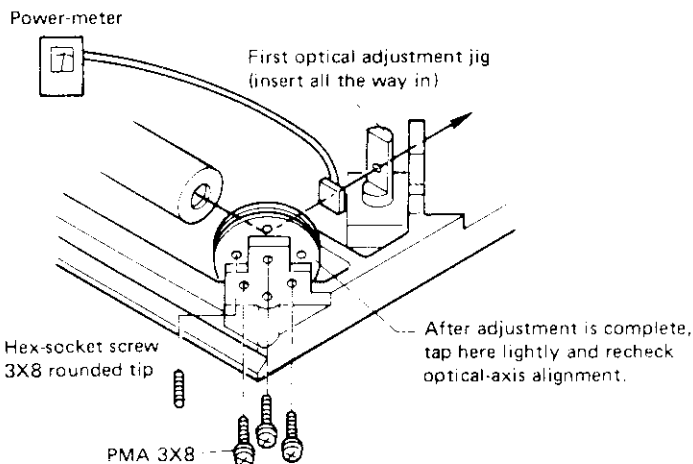

- (4) After the adjustment, confirm that the laser power at the position noted in the drawing measures 0.9mW to 1.6mW.

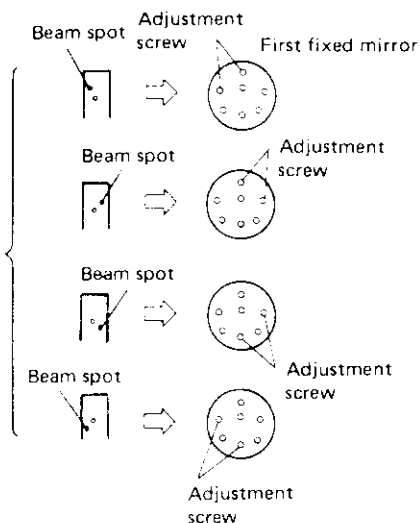

5. Second fixed mirror and grating adjustment

- (1) Attach the second fixed mirror.
- (2) Adjust the hex. socket adjustment screws behind the mirror so that the beam passes through the pin-hole of second optical axis adj. jig. The relation between the beam spot and the screws is same as the first fixed mirror adjustment.
- (3) Tap the back of the second fixed mirror lightly and recheck the optical axis.
- (4) Attach the grating.
- (5) Insert the grating adj. driver into the opening for the adjustment, then engage the grating driver with the cog of the grating.

- (6) Adjust the grating by rotating the grating driver so that the first order beam falls on the scratch line of the jig.
- (7) Installation of the grating will throw the zero order beam off a bit. Readjust second fixed mirror.
- (8) Repeat steps (6) and (7) until the following conditions are met.
 - The zero order beam passes through the pin-hole of the jig.
 - The first order beam falls on the scratch line of the jig.

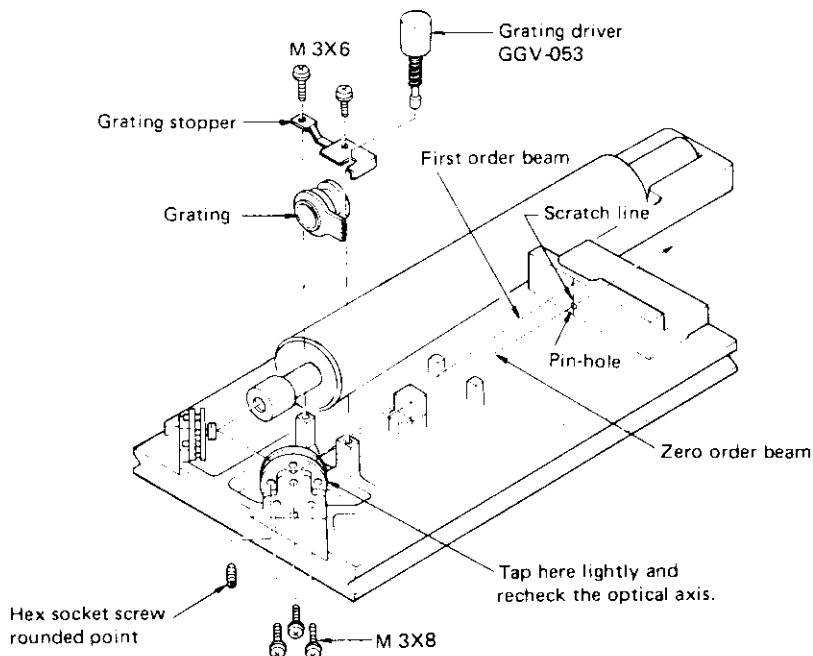

6. Tracking ass'y mounting

- (1) Detach the objective lens and the stopper base from the focus motor.

NOTE:

Do not put any object into the gap.

- (2) Attach the tracking ass'y.

NOTE:

When you exchange the tracking ass'y, new one must be re-aged before the adjustment for several hours with the slider base side up.

(Using 50Hz sin wave, 150mA)

CAUTION:

Do not leave the slider with the components side up for more than 15 minutes.

(The slider with the components side up is illustrated in the drawing below.)

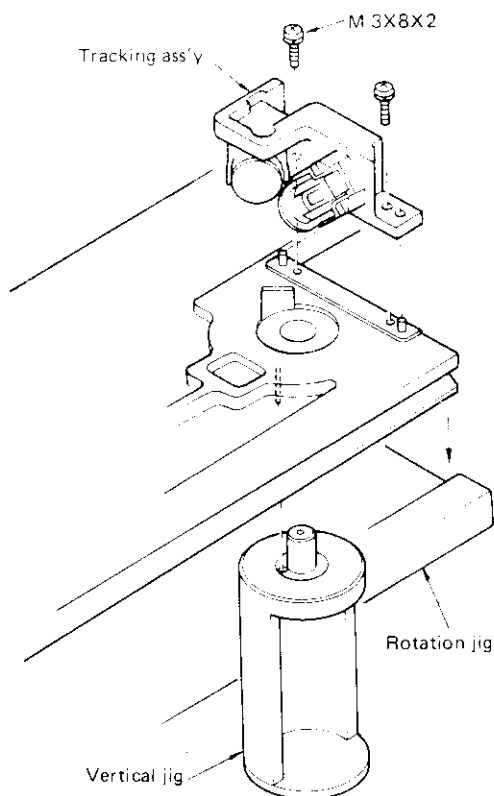

- (2) Next, using the two adjustment drivers, bring the beam onto the vertical center line on the lower pin-hole and temporarily tighten the screw.

2. Tangential mirror adjustment

With the set screw lightly tightened, use the two adjustment drivers and adjust the mirror axially and radially until the beam falls on the horizontal center line relative to the pin-hole. (Refer to Fig. B) Check and make sure the beam cleanly passes through the upper and lower pin-holes.

3. Screw down the set screws a bit and recheck the optical axis.
4. Repeat the steps listed in 1., 2. and 3. until the beam cleanly passes through the upper and lower pin-holes.
5. After the adjustment, screw down the two set screws at a clamping torque of 6kg·cm - 8kg·cm.

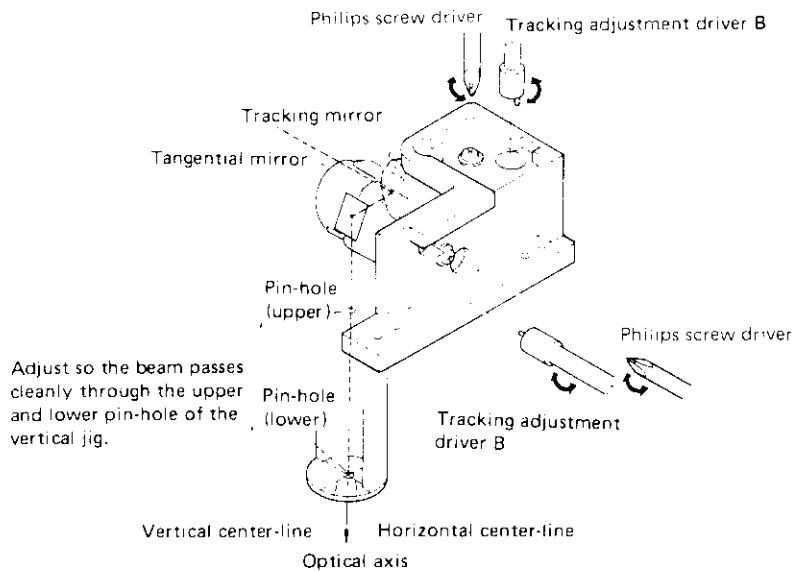

7. Tracking ass'y adjustment

1. Tracking mirror adjustment

- (1) With the set screw lightly tightened, use the two adjustment drivers to move the mirror axially and radially, and adjust so that the beam passes through the upper pin-hole in the vertical jig.

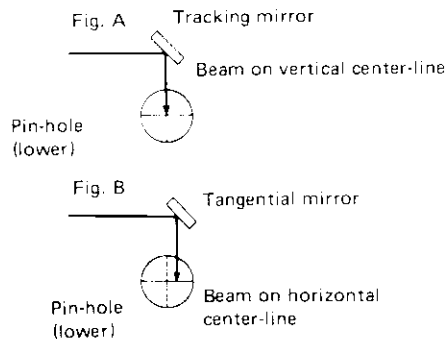

8. Optical axis adjustment with the slider base side up

- (1) Press the lever of the rotation jig and turn the whole slider unit over. Leave it alone in that posture for over one minute.
- (2) Insert the tracking driver B into the point illustrated in the drawing and slowly rotate in the direction of the arrow while observing the optical axis. Stop when the beam cleanly passes through the upper pin-hole.
- (3) Make sure the set screws for the tangential and tracking mirror are tight enough.
- (4) Press the lever of the rotation jig and bring the slider unit back.

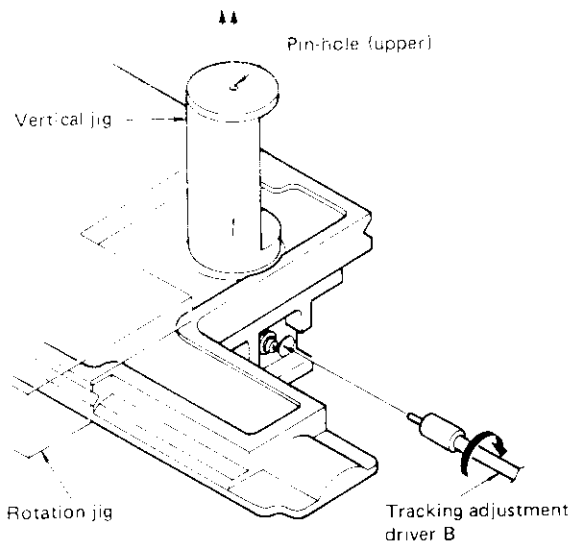

9. Diverging lens and 1/4 wave plate mounting

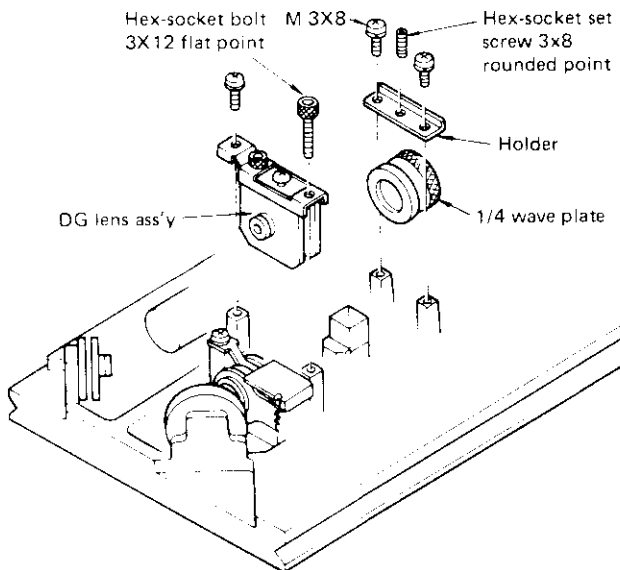

10. Diverging lens adjustment

- (1) Press the lever of the rotation jig and turn the slider unit over.
- (2) Set the oscillo scope into X-Y mode, and connect the output of position sensor jig as illustrated in the drawing.
- (3) Set the sensor into the center hole of the magnetic circuit.
- (4) Turn the DG adjustment screws (hex. socket head screw) so that the beam spot on the oscilloscope screen comes on the center of the screen.
- (5) Tap the * marked portion of the rotation jig lightly, and readjust the DG adjustment screws.
- (6) Repeat the steps listed in (4) and (5) until the displacement of the optical axis doesn't occur.
- (7) After the adjustment, detach the sensor from the slider.

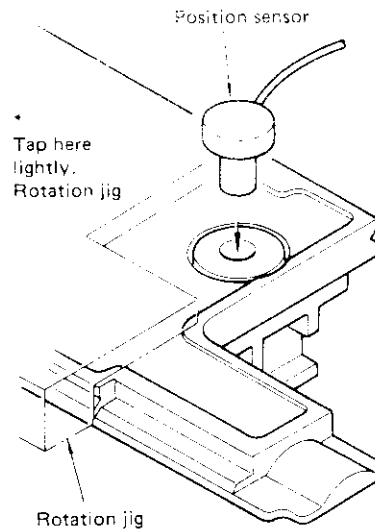

BLOCK DIAGRAM OF POSITION SENSOR JIG

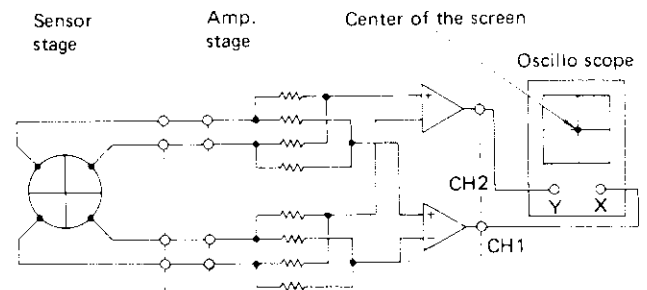

11. Objective lens mounting

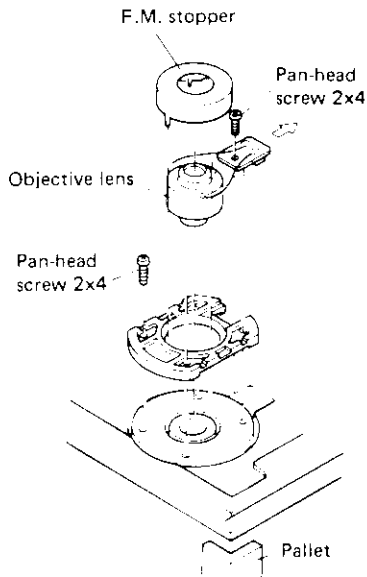

12. Check of stain on the optical parts

- (1) Press the lever of the rotation jig and turn the slider over.
- (2) After lighting the laser, put an orange colored paper under the objective lens, observe the projection of the beam on the paper.
- (3) If the beam is projected unevenly, first blow the dust on optical parts by an air blower, wipe the optical parts off by a piece of cleaning paper wetted with the following abstergent.

Objective lens: Mixture of fron and ethanol
 Grating: Pure fron (Don't wipe off grated side)

Other optical parts: Mixture of fron and ethanol

CAUTION:

Do not clean transducer mirrors.

13. Photo detector positioning and 1/4 wave plate adjustment

Preparation

- (1) Mount the slider on the static jig (stand A) and lock in place.
- (2) Prepare amp. jig, laser power supply and a dual trace oscilloscope, and connect them as shown in the connection diagram.

NOTE:

There is no connecting post for housing N-4 in old static jig. Therefore, it is necessary to modify the connector stand on the jig.

Adjustment

- (1) Turn on the power of the amp. jig and light on the laser.
- (2) Adjust the height of the moveable reflecting mirror, so the reflected beam focuses on the photo detector.
- (3) Set the function SW of the amp. jig to position 3, for observing the levels of TRKG A and TRKG B.
- (4) Adjust the photo detector position to make absolute value of TRKG A and TRKG B equal by turning the PD adjustment screws.
- (5) Fine adjust the height of the moveable reflecting mirror to make TRKG A and TRKG B levels maximum.
- (6) Repeat the steps (4) and (5) once or twice.
- (7) Set the function SW of the amp. jig into position 2 for observing the waveform of focus error.
- (8) Turn on the 300Hz OSC SW of the amp. jig to drive the moveable reflecting mirror.
- (9) Rotate the output VR of the 300Hz OSC in CW direction until a dip appears on the peak points of the focus error waveform.
- (10) Rotate the 1/4 wave plate to obtain maximum focus error.
- (11) Fine adjust the PD position to obtain maximum focus error.
- (12) Repeat above adjustment steps (3) to (11) until maximum focus error is obtained.
- (13) This adjustment result should meet the following criteria.
 - Focus error peak to peak value: more than 5.3V
 - The difference between value A and value B: within 10% of peak to peak value.
 - TRKG A and TRKG B should be approximately same level (absolute value).

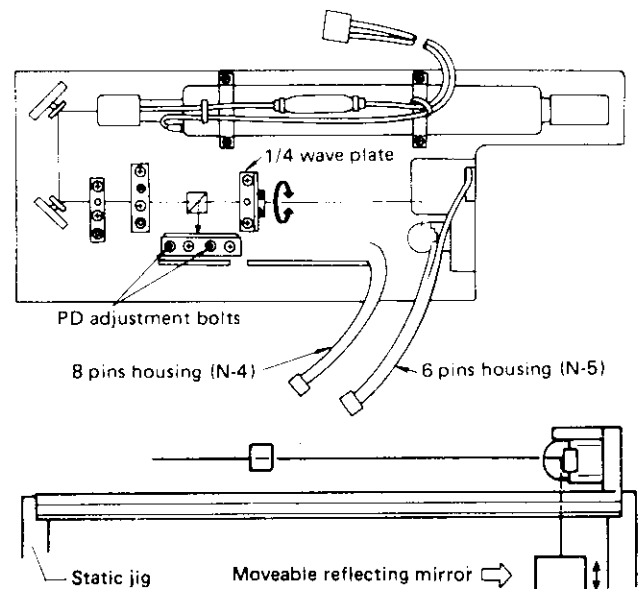
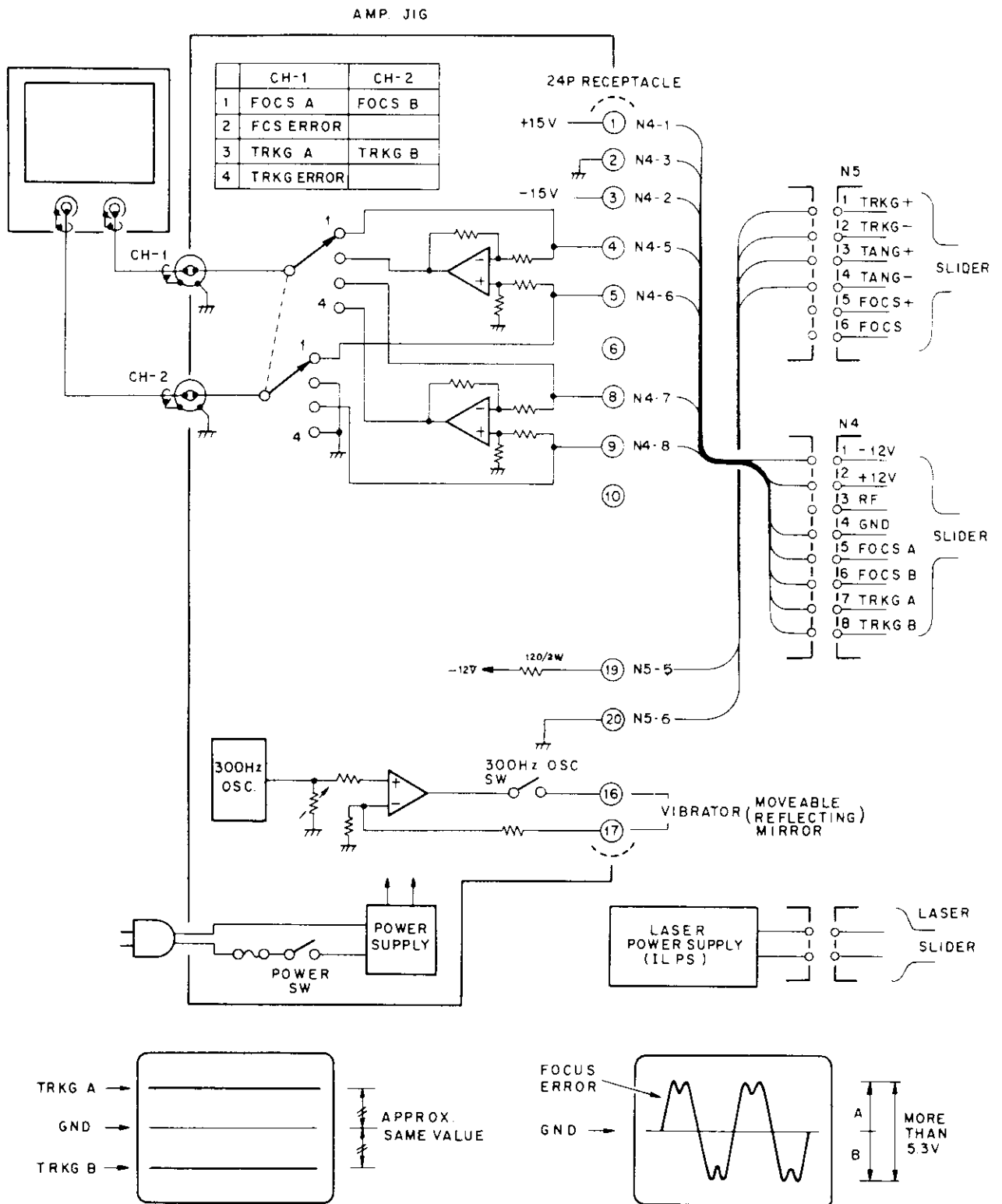
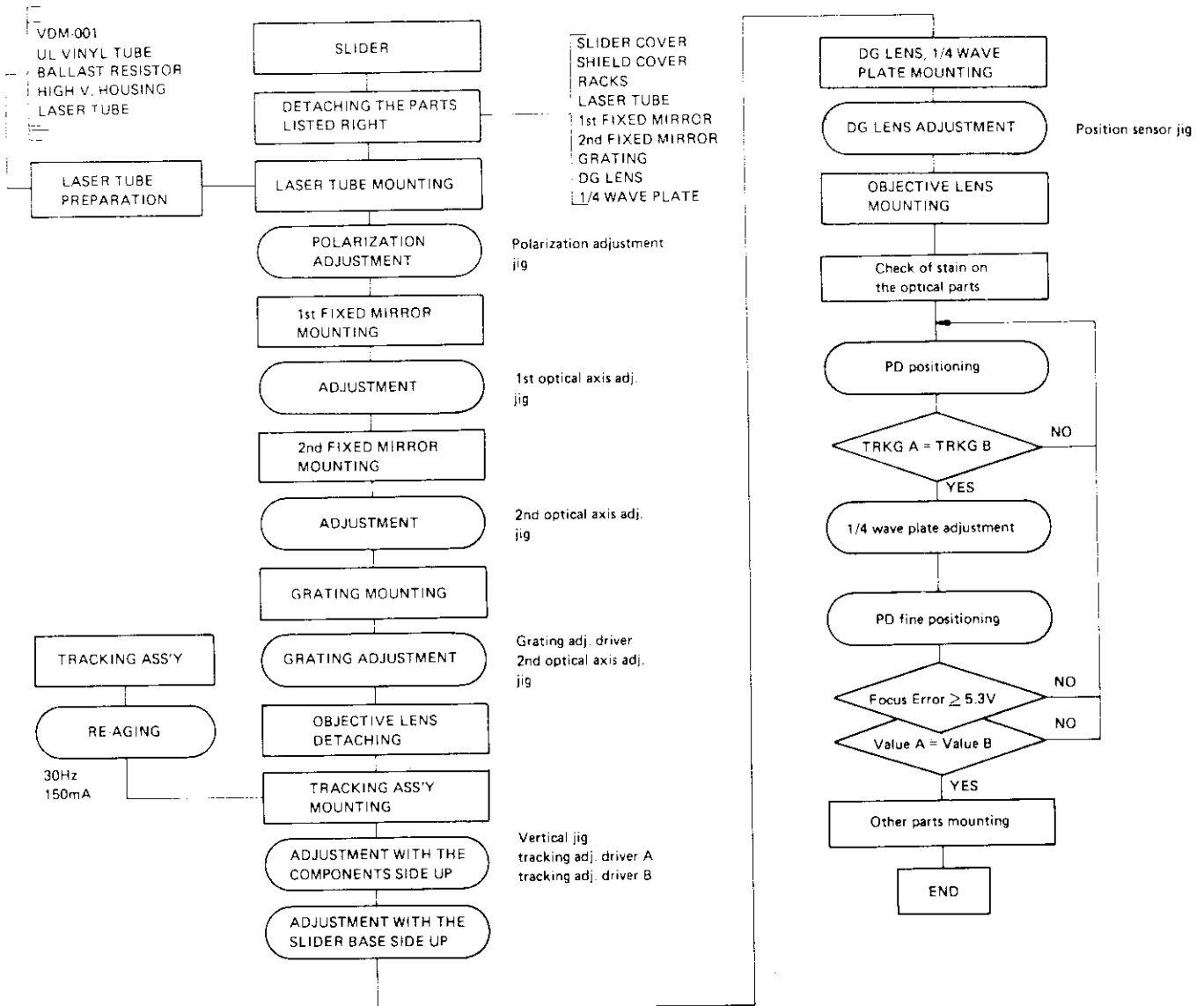

FIG. Connection diagram for the PD positioning and 1/4 wave plate adjustment.



14. Finishing

- (1) Apply "screw lock" to the following points.
 - Fixed mirrors 4 points of set screws
Hex. socket adjustment screws (4 ea.)
 - DG lens Hex. socket bolts (2 ea.)
 - 1/4 wave plate Hex. socket set screw (1 ea.)
 - Photo detector Hex. socket bolts (2 ea.)
 - Racks End of screws (6 ea.)
- (2) Attach all of the detached parts.
- (3) Always keep the objective lens upturned and lens cap attached.



9. ELECTRICAL ADJUSTMENTS

9-1. VSOP ADJUSTMENT

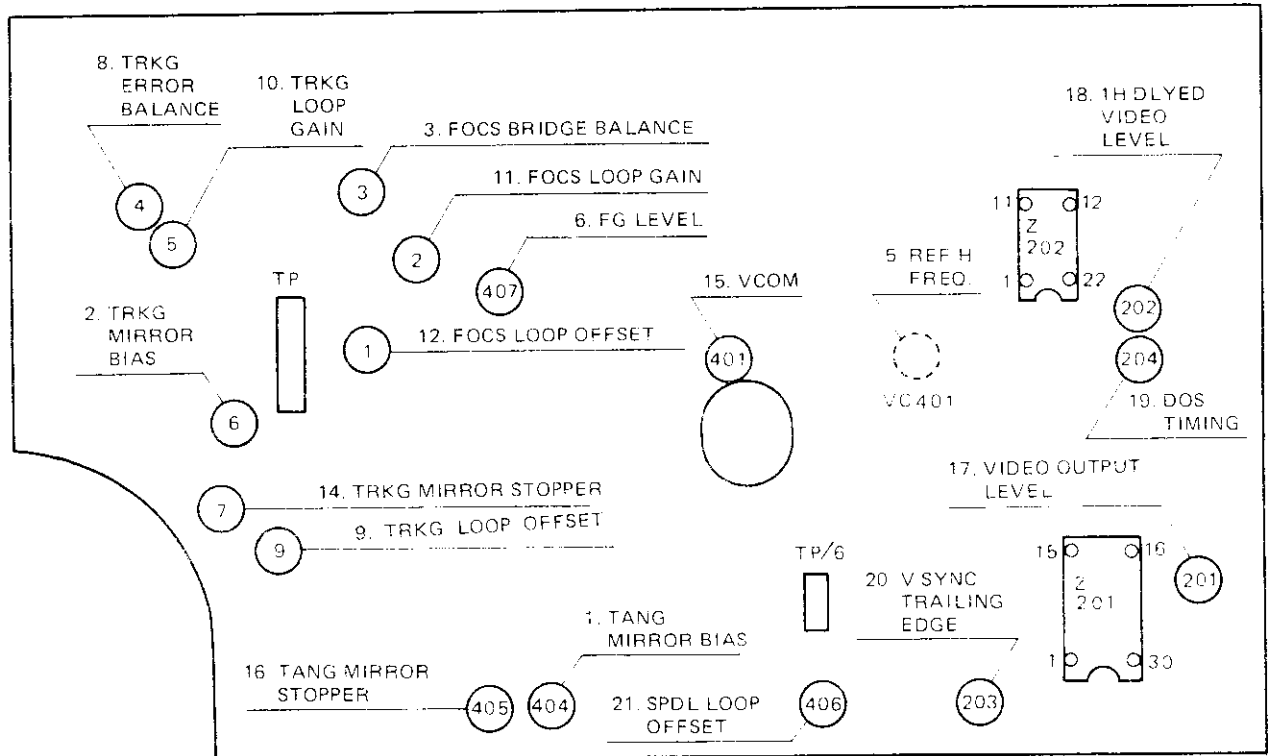

EQUIPMENTS AND TOOLS

- Oscilloscope
- Monitor TV
- Test disc B1
- AF oscillator
- Frequency counter
- 30° player stand
- Extension cables
- Low pass filter etc.

TEST POINT

TP	TP
1 focus error	1/6 tangential loop control (O/L: connect to GND)
2 osc input (FOCS)	2/6 playback H (PB H)
3 focus bridge balance	3/6 reference H (REF H)
4 GND	4/6 tangential error
5 tracking error	5/6 n.c.
6 osc input (TRKG)	6/6 f.g. level (FG)
7 tracking return	
8 tracking loop control (O/L: connect to GND)	
9 GND	
10 focus drive	
11 RF	
12 tangential return	

PRIOR TO VSOP ADJUSTMENT

- Remove the bottom cover.
- Using the 30° player stand, raise the front of the set.
- Remove the 4 screws on VSOP, then connect extension cables to the test points.
- Install the test disc B1.
- Turn on and hold the inter-lock switch and the lid switch.
- Plug the power cord into a 120V/60Hz outlet.

NOTE:

10:1 probes are used in these adjustments. Scope ranges are shown with the probe in use. However, it may be necessary with some scopes to use a 1:1 probe in X-Y mode to obtain sufficient gain.

WARNING:

EXTREME CARE MUST BE EXERCISED TO LSPS BOARD WHILE WORKING WITH THE PLAYER TO PREVENT POSSIBILITY OF EXPOSING YOURSELF TO DANGEROUS VOLTAGES.

Step No.	Mode	Scope Range	Servo Loop	Test Point No.	Adj. Point	Adjustment and Check Details
1	SET UP	5mV/div		TP-12	VR404	<p>When the adjustment mode is "SET UP", connect pin 1 of PSCB to GND, thereby the +12V and -12V lines on VSOP are activated.</p> <ul style="list-style-type: none"> ● TANG MIRROR BIAS Verify the voltage at TP-12 is $0 \pm 20\text{mV}$. If not, adjust VR404 to satisfy the above. This step is necessary when VSOP is replaced.
2	SET UP	5mV/div		TP-7	VR6	<ul style="list-style-type: none"> ● TRKG MIRROR BIAS Verify the voltage at TP-7 is $0 \pm 20\text{mV}$. If not, adjust VR6 to satisfy the above. This step is necessary when VSOP is replaced.
3	SET UP	5mV/div		TP-10 TP-3	VR3	<ul style="list-style-type: none"> ● FOCS BRIDGE BALANCE Connect TP-10 to GND. Measure the voltage at TP-3 (an offset voltage of Z2), then disconnect TP-10 from GND. Adjust VR3 so that the voltage at TP-3 will be 20mV lower than that measured voltage. This step must be finished within one minute after the power is turned on.
4	SET UP	5mV/div		TP-1	VR1	<ul style="list-style-type: none"> ● FOCS OFFSET INITIAL SET Verify the voltage at TP-1 is $0 \pm 30\text{mV}$. If not, adjust VR1 to satisfy the above.
5	SET UP			TP-3/6	VC401	<ul style="list-style-type: none"> ● REF H FREQUENCY Connect a frequency counter to TP-3/6. Verify REF H frequency is 15734Hz. If not, adjust VC401 to get near the above. If you have an NTSC generator, connect CH-1 of the scope to the H-SYNC OUT of the generator, and also connect CH-2 to TP-3/6. With triggering by CH-1 input, adjust VC401 to stop the current of the waveform in CH-2.

Step No.	Mode	Scope Range	Servo Loop	Test Point No.	Adj. Point	Adjustment and Check Details
6	PLAY		TANG O/L TRKG O/L	TP-6/6	VR407	<ul style="list-style-type: none"> ● SPDL LOCK CHECK <p>Connect TP-1/6 to GND to make TANG servo loop open. Push PLAY key and scan to middle of the disc.</p> <p>Verify SPDL servo loop has been locked. If not, F.G. level should be adjust.</p> <p>Push REJECT key, then set VR407 to the mechanical center. Again, push PLAY key; as soon as SPDL servo has been locked, adjust VR407 to 1.5V at TP-6/6.</p>
7	STILL =14,000	0.1V/div	TANG O/L TRKG O/L	TP-5	GRATING	<ul style="list-style-type: none"> ● TRKG ERROR CHECK <p>Verify TRKG error level is more than 2Vp-p. If not, the mounted angle of the diffraction grating must be adjusted.</p> <p>Scan to the point where the slider's hole for grating adjustment comes on the center of the mech. chassis opening, then push STILL key.</p> <p>Insert the grating driver into the opening, then engage the cogs of the grating and driver.</p> <p>While observing TRKG error, adjust the grating angle to find the smooth null point of the waveform. Then rotate the grating driver CCW direction to find the first point where maximum TRKG error with smooth envelope is obtained.</p>

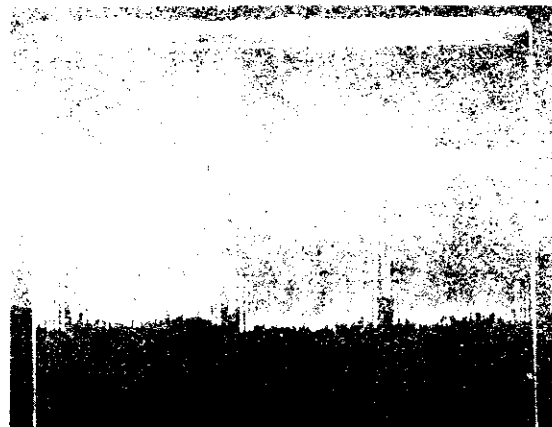
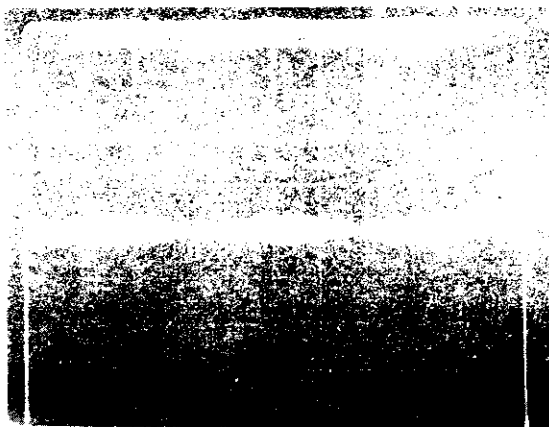

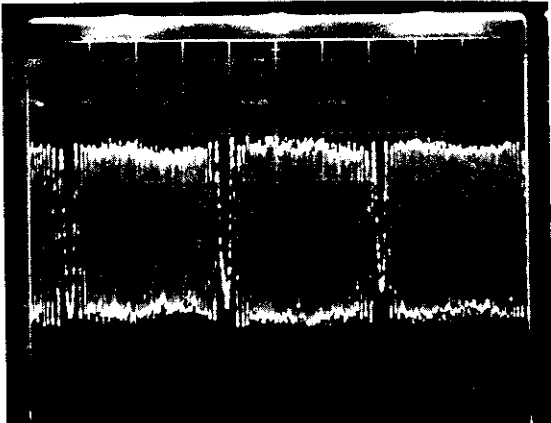
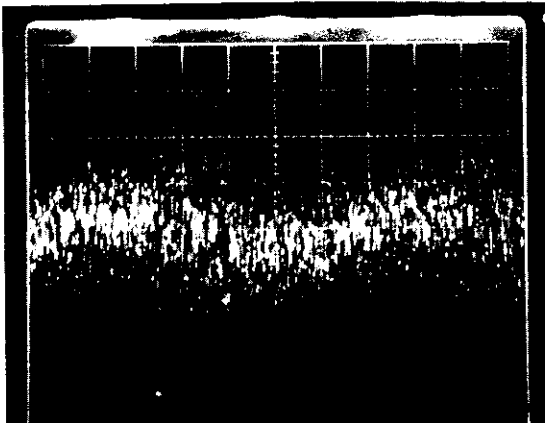
Step No.	Mode	Scope Range	Servo Loop	Test Point No.	Adj. Point	Adjustment and Check Details
8	PLAY #20,000	0.1V/div	TANG O/L TRKG O/L	TP-5	VR4	<p>● TRKG ERROR BALANCE</p> <p>Push PLAY key and scan to middle of the disc. With TRKG and TANG servo loop still opened, adjust VR4 to where TRKG error waveform is centered on 0V, or the positive and negative peak amplitudes are same level.</p> 
9	PLAY	0.1V/div	TRKG C/L	TP-5	VR9	<p>● TRKG LOOP OFFSET</p> <p>Disconnect TP-8 from GND to make TRKG servo loop close. Adjust VR9 to where TRKG error waveform is centered on 0V.</p> 

Step No.	Mode	Scope Range	Servo Loop	Test Point No.	Adj. Point	Adjustment and Check Details
10	PLAY =20,000	CH-X: 0.2V/div CH-Y: 50mV/div	TANG O/L TRKG C/L	TP-6 TP-5	VR5	<p>● TRKG LOOP GAIN</p> <p>Disconnect TP-8 from GND. Set the scope into X-Y mode and the AF oscillator output to 4.8kHz (10Vp-p). Scan to middle of the disc. Connect the oscillator output to CH-X and also to TP-6 through a 68kΩ. Connect CH-Y to TP-5. Adjust VR5 to make Lissajous figure into a horizontal ellipse.</p> <div data-bbox="973 672 1380 1008" data-label="Diagram"> </div> <div data-bbox="917 1092 1476 1522" data-label="Image"> </div>

Step No.	Mode	Scope Range	Servo Loop	Test Point No.	Adj. Point	Adjustment and Check Details
11	PLAY #20,000	CH-X: 10mV/div CH-Y: 20mV/div	TANG O/L TRKG C/L	TP-2 TP-1	VR2	<p>● FOCS LOOP GAIN</p> <p>Set the scope into X-Y mode and the AF oscillator output to 2.4kHz (0.6Vp-p). Scan to middle of the disc.</p> <p>Connect the oscillator output to CH-X and also to TP-2 through a 68kΩ. Connect CH-Y to TP-1. Adjust VR2 to make Lissajous figure into a horizontal ellipse.</p>

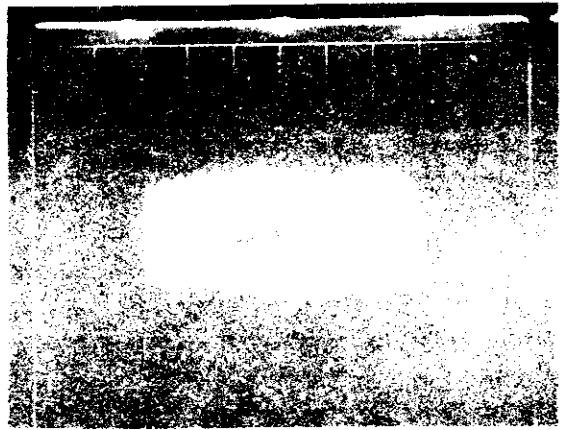
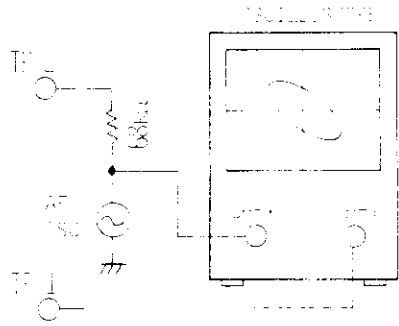

Step No.	Mode	Scope Range	Servo Loop	Test Point No.	Adj. Point	Adjustment and Check Details
----------	------	-------------	------------	----------------	------------	------------------------------

12
 PLAY
 =100
 ↓
 SET UP
 TANG
 C/L
 TRKG
 C/L
 TP-11
 TP-1
 VR1

● FOCUS LOOP OFFSET

Disconnect TP-8 and TP-1/6 from GND. Push PLAY key. While observing RF signal at TP-11, adjust VR1 to obtain maximum RF signal. Next, while observing FOCUS error at TP-1, conform the center of the waveform to a horizontal center line on CRT. Push REJECT key, verify the offset voltage is $0 \pm 0.1V$. If not, adjust VR1 to satisfy the above.

13
 PLAY
 =20,000
 TANG
 O/L
 TRKG
 O/L

● OPTICAL PATH CHECK

This step has to be performed when the slider is replaced or the problem seems to relate with the optical path.
 Connect TP-8 and TP-1/6 to GND. Push PLAY key and scan to middle of the disc. TRKG and TANG mirrors are classified into five ranks by their sensitivities as shown below and their ranks designated on the connector housing. Verify the mirror ranks. Connect each end of jig VR to +12V line and -12V line of VSOP, and also the center tap to TP-7 through the resistor corresponding to the mirror rank.
 Connect the scope to TP-5.
 Adjust the jig VR to obtain maximum TRKG error, and read the peak-to-peak amplitude: Eto.
 Rotate the jig VR so that maximum positive mirror bias is put to TRKG mirror, and read the peak-to-peak amplitude: Etp.
 Rotate the jig VR so that maximum negative mirror bias is put to, and read Etn.
 Make sure the followings
 $Etp > 0.65 \times Eto$, and $Etn > 0.65 \times Eto$
 Likewise, put mirror bias to TANG mirror at TP-12, and measure TRKG error peak-to-peak amplitudes Eto, Etp and Etn at TP-5. Then, make sure the above.

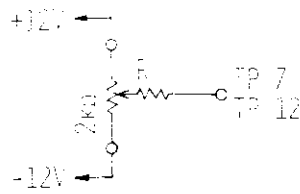
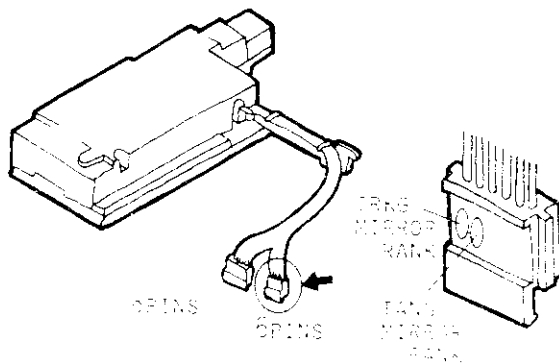

CHECK OUT

Mirror Rank			R(Ωhm)
Code	Color	No	
C1	Black	1	316
C2	Red	2	300
C3	Yellow	3	273
D	Blue	4	240
E	Green	5	218

Step No.	Mode	Scope Range	Servo Loop	Test Point No.	Adj. Point	Adjustment and Check Details																											
14	SCAN FWD		TANG C/L TRKG C/L	TP-7	VR7	<p>● TRKG MIRROR STOPPER</p> <p>Insert a low pass filter (47kΩ/0.01μF) between the probe and the scope input (CH-Y), set the oscilloscope into X-Y mode.</p> <p>Connect the probe to TP-7, and verify the ground level in CH-Y input. (CH-X isn't used.)</p> <p>While scanning to forward direction, adjust VR7 to obtain a positive voltage depending on the mirror rank. Mirror ranks and set point are shown below.</p> <table border="1" data-bbox="912 705 1444 1016"> <thead> <tr> <th colspan="3">Mirror Rank</th> <th rowspan="2">Set point (V)</th> </tr> <tr> <th>Code</th> <th>Color</th> <th>No</th> </tr> </thead> <tbody> <tr> <td>C1</td> <td>Black</td> <td>1</td> <td>0.50 ± 0.05</td> </tr> <tr> <td>C2</td> <td>Red</td> <td>2</td> <td>0.55 ± 0.05</td> </tr> <tr> <td>C3</td> <td>Yellow</td> <td>3</td> <td>0.60 ± 0.05</td> </tr> <tr> <td>D</td> <td>Blue</td> <td>4</td> <td>0.70 ± 0.10</td> </tr> <tr> <td>E</td> <td>Green</td> <td>5</td> <td>0.90 ± 0.10</td> </tr> </tbody> </table>	Mirror Rank			Set point (V)	Code	Color	No	C1	Black	1	0.50 ± 0.05	C2	Red	2	0.55 ± 0.05	C3	Yellow	3	0.60 ± 0.05	D	Blue	4	0.70 ± 0.10	E	Green	5	0.90 ± 0.10
Mirror Rank			Set point (V)																														
Code	Color	No																															
C1	Black	1	0.50 ± 0.05																														
C2	Red	2	0.55 ± 0.05																														
C3	Yellow	3	0.60 ± 0.05																														
D	Blue	4	0.70 ± 0.10																														
E	Green	5	0.90 ± 0.10																														
15	PLAY #1,000	5mV/div	TANG C/L TRKG C/L	TP-4/6	VR401	<p>● VCOM</p> <p>Adjust VR401 to minimize the TANG error waveform in vertical blanking interval of the video signal at TP-4/6.</p>																											

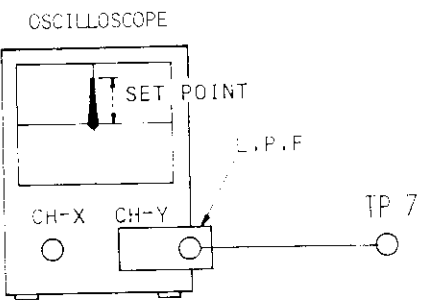

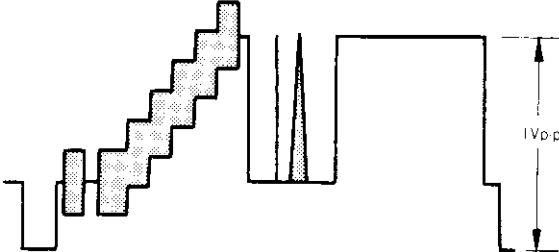
Step No.	Mode	Scope Range	Servo Loop	Test Point No.	Adj. Point	Adjustment and Check Details																																			
16	PLAY #1,000	10mV/div	TANG C/L TRKG C/L ↓ TANG O/L	TP-12	VR405 VR404	<p>● TANG MIRROR STOPPER</p> <p>Insert a low pass filter (47kΩ/0.01μF) between the probe and the scope input. Connect the probe to TP-12.</p> <p>Rotate VR405 fully CW direction, adjust VR404 to obtain the set point X. (shown below)</p> <p>Rotate VR405 slowly to CCW direction and adjust to the set point Y at TP-12.</p> <p>Connect TP-1/6 to GND, readjust VR404.</p> <table border="1" data-bbox="917 667 1449 982"> <thead> <tr> <th colspan="3">Mirror Rank</th> <th colspan="2">Set point</th> </tr> <tr> <th>Code</th> <th>Color</th> <th>No</th> <th>X(V)</th> <th>Y(V)</th> </tr> </thead> <tbody> <tr> <td>C1</td> <td>Black</td> <td>1</td> <td>-0.55</td> <td>-0.40</td> </tr> <tr> <td>C2</td> <td>Red</td> <td>2</td> <td>-0.60</td> <td>-0.45</td> </tr> <tr> <td>C3</td> <td>Yellow</td> <td>3</td> <td>-0.65</td> <td>-0.50</td> </tr> <tr> <td>D</td> <td>Blue</td> <td>4</td> <td>-0.70</td> <td>-0.55</td> </tr> <tr> <td>E</td> <td>Green</td> <td>5</td> <td>-0.80</td> <td>-0.65</td> </tr> </tbody> </table>	Mirror Rank			Set point		Code	Color	No	X(V)	Y(V)	C1	Black	1	-0.55	-0.40	C2	Red	2	-0.60	-0.45	C3	Yellow	3	-0.65	-0.50	D	Blue	4	-0.70	-0.55	E	Green	5	-0.80	-0.65
Mirror Rank			Set point																																						
Code	Color	No	X(V)	Y(V)																																					
C1	Black	1	-0.55	-0.40																																					
C2	Red	2	-0.60	-0.45																																					
C3	Yellow	3	-0.65	-0.50																																					
D	Blue	4	-0.70	-0.55																																					
E	Green	5	-0.80	-0.65																																					
17	STILL #100~ #1,000	20mV/div	TANG C/L TRKG C/L	VIDEO OUT	VR201	<p>● VIDEO OUTPUT LEVEL</p> <p>Player in STILL mode in "Composite test" signal reproducing.</p> <p>With Video Output terminated into 75Ω, verify the video level is 1 ± 0.1V from sync tip to white peak. If not, adjust VR201 to satisfy the above.</p> 																																			

Step No.	Mode	Scope Range	Servo Loop	Test Point No.	Adj. Point	Adjustment and Check Details
18	STILL ≠100~ ≠1,000	20mV/div	TANG C/L TRKG C/L	Z201 pin-16 pin-18	VR202	<ul style="list-style-type: none"> ● 1H DELAYED VIDEO LEVEL Verify the video level at pin-16 of Z201 is equal to the level at pin-18. If not, adjust VR202 to satisfy the above.
19	SET UP	0.2V/div	TANG C/L TRKG C/L	TP-11 Z201 pin-14	VR204	<ul style="list-style-type: none"> ● DOS TIMING Input a signal of 5.5MHz (200mVp-p) to TP-11. Rotate VR204 fully CW, then back to CCW until the voltage at pin-14 of Z201 turns H to L.
20	PLAY ≠20,000		TANG C/L TRKG C/L	N9-7 Z201 pin-6	VR203	<ul style="list-style-type: none"> ● V SYNC TRAILING EDGE TIMING Play in the vicinity of ≠20,000. Verify that V SYNC trailing edge is aligned with the position between the 1st and 2nd equalizing pulses in COMP SYNC (pin-6 of Z201) after that trailing edge. If not, adjust VR203 to satisfy the above.



Step No.	Mode	Scope Range	Servo Loop	Test Point No.	Adj. Point	Adjustment and Check Details
21	PLAY #20,000	0.2V/div	TANG O/L TRKG C/L	TP-3/6 TP-2/6	VR406	<p>● SPDL LOOP OFFSET</p> <p>Connect TP-1/6 to GND and play in the vicinity of #20,000.</p> <p>Adjust VR406 to align the center of the leading edge of PB H (TP-2/6) including jitter with the leading edge of REF H (TP-3/6).</p> <p>After 20 to 30 seconds, verify that the phase difference between PB H and REF H is less than ± 2 sec. If it is greater, adjust VR406 again.</p> <p>Disconnect TP-1/6 from GND and make sure that there is no red streak or other color distortion in the TV monitor.</p>

9-2. CONT ADJUSTMENT

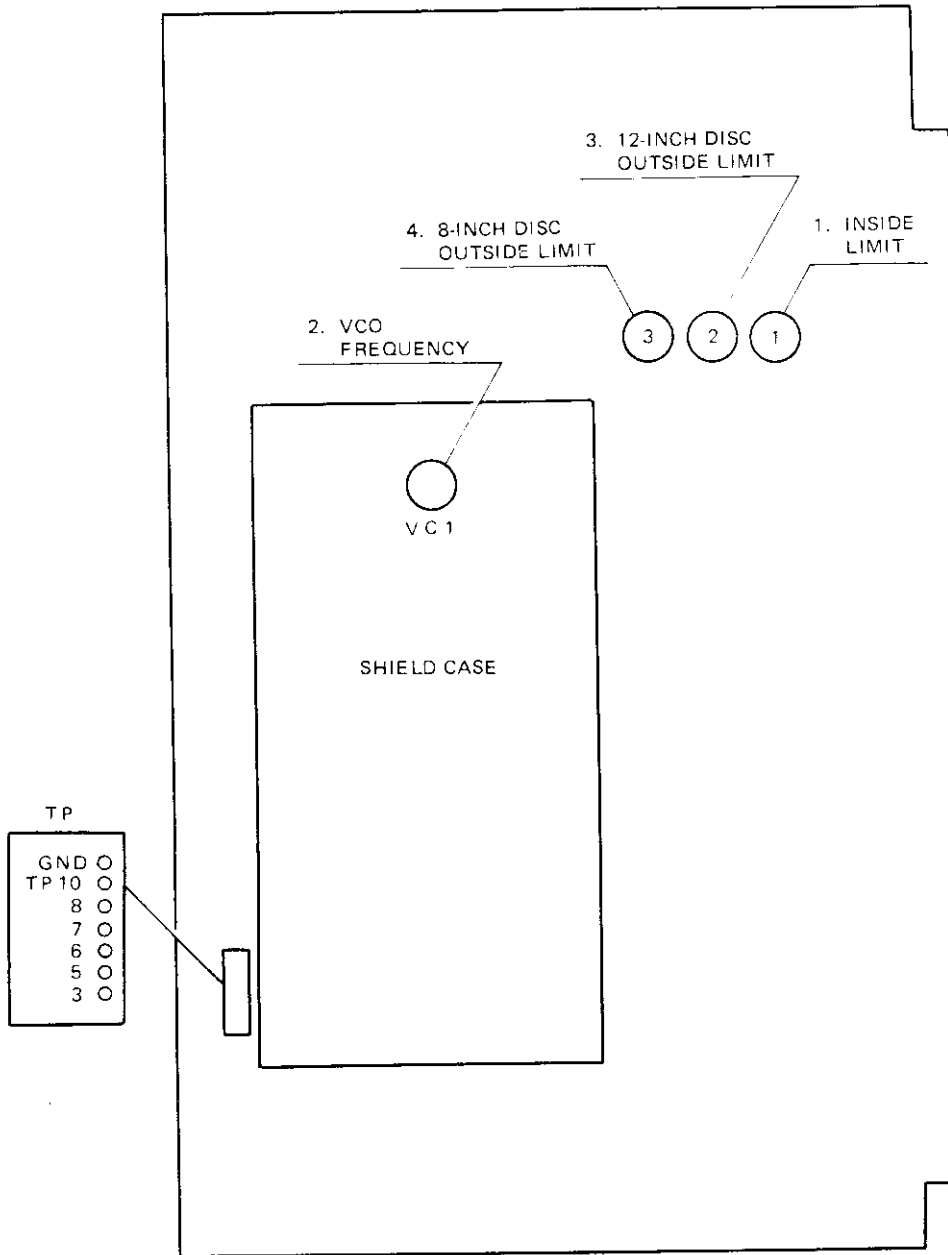

NOTE: Use B1 TEST DISC in adjustments.

Step No.	Mode Fr. No.	Servo Loop	Test Point	Adj. Point	Details
1.	Inner most track	TRKG O/L	TV monitor	VR1	<ul style="list-style-type: none"> ● INSIDE LIMIT ADJUSTMENT Following PLAY mode, proceed with SCAN FWD and REV modes, and adjust VR1 so that STILL mode is obtained between LEAD-IN No. 8 and 10 on the TV monitor. (No. 9 should be seen.)
2.	PLAY	C/L	TP7	VC1	<ul style="list-style-type: none"> ● VCO ADJUSTMENT Turn VC1 inside of the shield case to obtain a voltage at TP7 of approx. 4V so that the FRAME No. display is steady on the monitor.
3.	Outer most track		TP5 TP6 TP3 TP10	VR2	<ul style="list-style-type: none"> ● 12-INCH DISC OUTSIDE LIMIT ADJUSTMENT Clip TP5 and TP6 together with shorting clips, SEARCH for FRAME No. 50,400 or over, and make sure that the mode is changed to STILL in FRAME No. 50,400. STEP FWD to obtain LEAD-OUT Nos. on the monitor. Adjust VR2 so that a voltage at TP3 switches from L to H in LEAD-OUT No. 10 near by. Connect TP10 to the ground and make sure that the FOCS motor is pull down between LEAD-OUT No. 19 and the outer end of the disc.
4.	PLAY #23,500		TP5 TP6 TP8 TP3	VR3	<ul style="list-style-type: none"> ● 8-INCH DISC OUTSIDE LIMIT ADJUSTMENT Clip TP5 and TP6 together with a shorting clips, and connect a 10kΩ resistor between TP5 and TP8 (thereby turning Q3 on). SEARCH for FRAME No. 23,500, and set VR3 to the very limit where a voltage at TP3 doesn't switch from H to L. Switch to PLAY mode and make sure that a voltage at TP3 switches from H to L between FRAME No. 23,900 and 24,000.

9-3. AUDX ADJUSTMENT

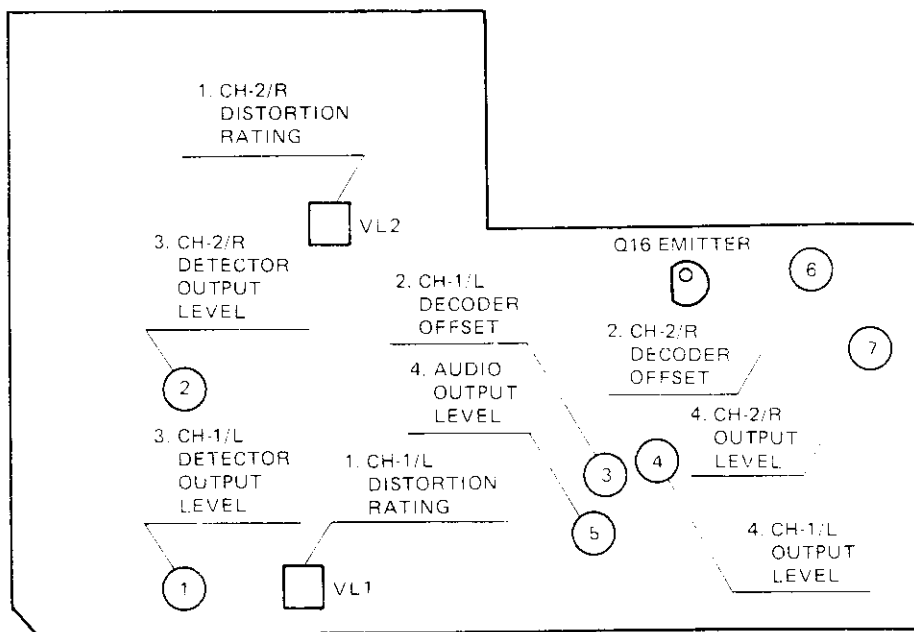

Step No.	Mode	Equipment	Adjustment Point	Details
1	PLAY #3,601~ #4,500	Level meter Distortion meter	VR5 VR1 VR4 VR2 VR7 VL1 VL2	<p>● AUDIO OUTPUT CHECK</p> <p>Connect a level meter to Audio Output terminated into 51kΩ.</p> <p>Switch CX off, and turn VR5 to the mechanical center.</p> <p>Set the player to PLAY mode in #3,601. (1kHz, 75%mod.)</p> <p>Make sure that the audio output is 490 ± 100mV-rms for both channels; 1/L and 2/R. If not, adjust VR to satisfy the above.</p> <p>1/L: Set VR1 to the mechanical center, and make rough adjustment with VR4.</p> <p>2/R: Set VR2 to the mechanical center, and make rough adjustment with VR7.</p> <p>Switch only 1/L channel on, and adjust VL1 to minimize distortion in 1/L channel.</p> <p>Switch only 2/R channel on, and adjust VL2.</p> <p>The distortion rating for both channels should be less than 0.3%.</p>



Step No.	Mode	Equipment	Adjustment Point	Details
2	STILL	Milivolt-meter	VR3 VR6	<ul style="list-style-type: none"> ● DECODER OFFSET Connect a milivolt-meter to Audio Output terminated into $51k\Omega$. While pressing CX key on and off repeatedly as fast as possible, adjust VR3 so that the deflection of the pointer is less than 1.5mV in 1/L channel. Similarly, adjust VR6 in 2/R channel.
3	PLAY $\approx 6,301\sim$ $\approx 7,200$. $\approx 3,601\sim$ $\approx 4,500$	Volt-meter	VR1 VR2	<ul style="list-style-type: none"> ● DETECTOR OUTPUT LEVEL In CX on mode, set to PLAY mode in $\approx 6,301$. (nonmodulation) Measure a voltage at Q16 emitter; Ecn. Switch only 1/L channel on, and set to PLAY mode in $\approx 3,601$. (1kHz, 75%mod.) Adjust VR1 so that the voltage at Q16 emitter comes $9.375 \times Ecn$. Similarly, adjust VR2 in 2/R channel.
4	PLAY $\approx 3,601\sim$ $\approx 4,500$	Level meter	VR4 VR7 VR5	<ul style="list-style-type: none"> ● AUDIO OUTPUT LEVEL In CX on mode, set to PLAY mode in $\approx 3,601$. (1kHz, 75%mod.) Adjust VR4 so that 1/L channel output level comes 914mVrms, and adjust VR7 in 2/R channel. Switch CX off, and adjust VR5 to obtain the audio output level in both channels of $488 \pm 20mVrms$.

10. TROUBLE SHOOTING

Problem	Cause	Check Point
Lid fails to open when REJECT/OPEN button is pressed.	Slider is not in PARK position, and cannot be activated. Defective slider driver gear.	If the slider motor is turning, replace the slider drive gear section.
	Defective slider motor.	If drive voltage is applied to the slider motor, replace the slider motor.
	Defective slider servo circuit.	If no drive voltage is applied to the slider motor, check UN4004 (12) in the VSOP. If a negative voltage (-6V) is detected when the REJECT button is pressed, check the subsequent drive circuit.
	VSOP N7-3 (SCANA) - L N7-1 (SCANC) - L is normal	
	Plunger fails to move Defective plunger.	If a -20V voltage is generated at SYPS (13) when the REJECT button is pressed, the plunger is defective.
	Defective plunger drive circuit.	An output voltage of -20V will not appear at SYPS (13) if LIDOPN +2V (min.) from CONT is applied to SYPS (14) when the REJECT button is pressed.

Problem	Cause	Check Point
Disc fails to rotate when PLAY button is pressed.	Laser beam not on.	<p>Check whether inter-lock switch or lid switch has depressed when the lid is closed.</p> <p>Check inter-lock switch and lid switch for conductivity.</p> <p>Check whether <u>LASER ON</u> switch is applied to LSPS (12) from CONT.</p> <p>Check relevant LSPS points, especially if the +12V line tends to be low.</p>
	No lens up operation Defective focus motor	<p>Measure DC resistance in focus motor. Normal value is about 10Ω.</p> <p>Check that there is no obstruction to focus motor movement.</p>
	Defective bridge balance adjustment	VSOP adjustment, step 3.
	No <u>FOCS ON</u> signal	Check presence of <u>FOCS ON</u> signal at VSOP (N7-5) when PLAY button is pressed.
	Defective drive circuit	Check for generation of drive voltage at VSOP (N5-5).
	Proper focus cannot be attained Lens needs cleaning.	Clean lens.
	Defective RFAM	Check that the focus error voltage describes an S-shape curve at VSOP TP-1 when lens is moved up. Normal level: ±2V p-p min.
	Slider beam axis out of alignment Excessive TANG or TRKG bias	<p>Place a piece of paper over the lens, and move the lens up. If a "bight" is taken out of the beam spot, the problem is due either to misalignment of the slider beam axis, or excessive bias.</p> <p>TANG bias at TP-12: 0 ±20mV</p> <p>TRKG bias at TP-7: 0 ±20mV.</p>
	Defective FOCS gain adjustment	VSOP adjustment, step 11.
	Defective FOCS servo circuit	Check Z1, Z3, Q1 and other elements.

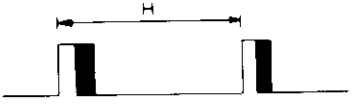
Problem	Cause	Check Point
Disc fails to rotate when PLAY button is pressed.	Defective SPDL motor. No <u>SPDL RUN</u> signal FOCS LOCK signal not applied to CONT after focussing. Defective CONT Defective SPDL servo circuit	Check for generation of motor drive voltage (about +20V) at VSOP (N8-6) after focussing. Failure to rotate when this voltage is applied to the SPDL motor indicates a defective SPDL motor. Does FOCS LOCK signal appear at VSOP (N7-6)? Is FOCS LOCK signal applied to CONT (N13-1)? Is <u>SPDL RUN</u> signal applied to VSOP (N9-2)? Does SPDL RUN signal appear at CONT (N14-8)? Failure to generate the drive voltage at VSOP (N8-6) when the <u>SPDL RUN</u> signal is applied to UM3002 (24) indicates a defective SPDL servo circuit.
Disc stops after rotating for only a few seconds.	Defective SPDL motor. Defective FG adjustment	VSOP adjustment, step 6.
SPDL servo lock failure	Defective FG adjustment Defective RFAM or VDEM Defective UM5003 Defective UM3001 Defective SPDL offset adjustment	VSOP adjustment, step 6. Check presence of RF SENS signal at UM3002(26). Check presence of <u>COMP SYNC</u> signal at UM5003 (13). REF H (15.734kHz) should appear at TP3. Check that PB H is generated at TP2. Check for appearance of the PFC output at UM3001 (10) (oscilloscope V rate).  VSOP adjustment, step 21.

Problem	Cause	Check Point
TRKG servo not applied	Defective TRKG mirror Defective disc sensor circuit Grating adjustment out of alignment TRKG balance or TRKG gain adjustment out of alignment	Check voltage at TP-7 (TRKG return) Normally TP8 +1.5V min. A TRKG error of 2.5Vp-p min. will normally be obtained at TP-5 when TP-8 is connected to ground. VSOP adjustment, step 8~10.
SPDL lock activated, but no picture	Defective UA5001 Defective CONT	Check for presence of video signal at UA5001 (1). Check release of VIDEO SQ after SPDL lock. UA5001(2) normally at H level.
No color	Defective TANG mirror Defective TANG mirror drive circuit Defective UM5003	Turn VR404 (TANG bias) around and check for voltage changes at TP-12 (TANG return). Ditto Video signal should appear at UM5003(2). Sampling pulse should be generated at UM5003(27).  The following waveform should appear at UM5003 (3).  TANG error should appear at TP4.

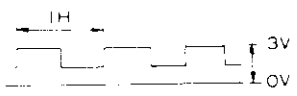
Problem	Cause	Check Point
Color drop-outs	Defective TANG loop control circuit SPDL offset adjustment output Defective SYNC gate	Check Z408 (1/2), Q435 and Q416. VSOP adjustment, step 21. When UM5003(12) is normal 
Trick play such as still playback not possible. Still playback not possible.	Microcomputer fails to read data JUMP TRIG not applied. No jump pulse output	Check for data output at UA5002(3). (N14-3) Does JUMP TRIG signal appear at VSOP (N7-4)? Does JUMP TRIG signal appear at CONT (N13-8)? Check for generation of jump pulse at UM4004(1).
Chapter (frame) number search not possible	VDEM VR203 adjustment out of alignment Unstable VSYNC (vertical movement)	VSOP adjustment, step 20. Check VDEM VR203 and surrounding time constant circuits.
Unsteady display (of frame number etc).	Defective CONT VC1 adjustment (lateral movement) Level of video input applied to RFMD is too high	CONT adjustment, step 2. VSOP adjustment, step 17.
Scanning not possible	Defective CONT Defective UM4004	Check for presence of SCANA at VSOP N7(3). (L level) Does ±3.3V appear at UM4004(12)?
Color drop-out during scanning	TRKG mirror stopper adjustment out of alignment Slider beam axis out of alignment	VSOP adjustment, step 16. VSOP adjustment, step 13.

11. SCHEMATIC DIAGRAMS, PCB PATTERNS AND PARTS LISTS

11-1 OVERALL

- The *A* mark found on some component parts indicates the importance of the safety factor of the part. Therefore, when replacing, be sure to use parts of identical designation.

CIRCUIT BOARDS

Mark	Part No.	Symbol & Description
	VWR-019	SYPS
	VWR-011	LSPS
	VWM-001	MCNB
	VWV-010	RFAM
	VWS-022	VSOP
	VWV-023	CPCB
	VWG-043	PSCB
	VWV-044	AUDX
	VWG-102	CONT
	VWG-044	GATB
	VWG-101	IOIB
	VWG-045	IRAB
	VWW-046	KEYC

OTHERS

Mark	Part No.	Symbol & Description
	VTT-016	Power transformer
	VXM-017	Spindle motor
	VXM-008 (VXM-010)	Slider motor
	VXP-005	Plunger
	VGX-023	Slider assembly
	VSA-006	SW1 Power switch
	VSF-006	SW2 Interlock switch
	VSF-007	SW3 Lid switch
	SM1A-02	D1
	RD1/4PM271J	R1
	VCS-005	Potentiometer
	VCG-011	C1
	VCG-005	C2-C5
	CKDYF333Z50	C6
	VDG-016	Power cord
	VDA-013	H.V. cord assembly

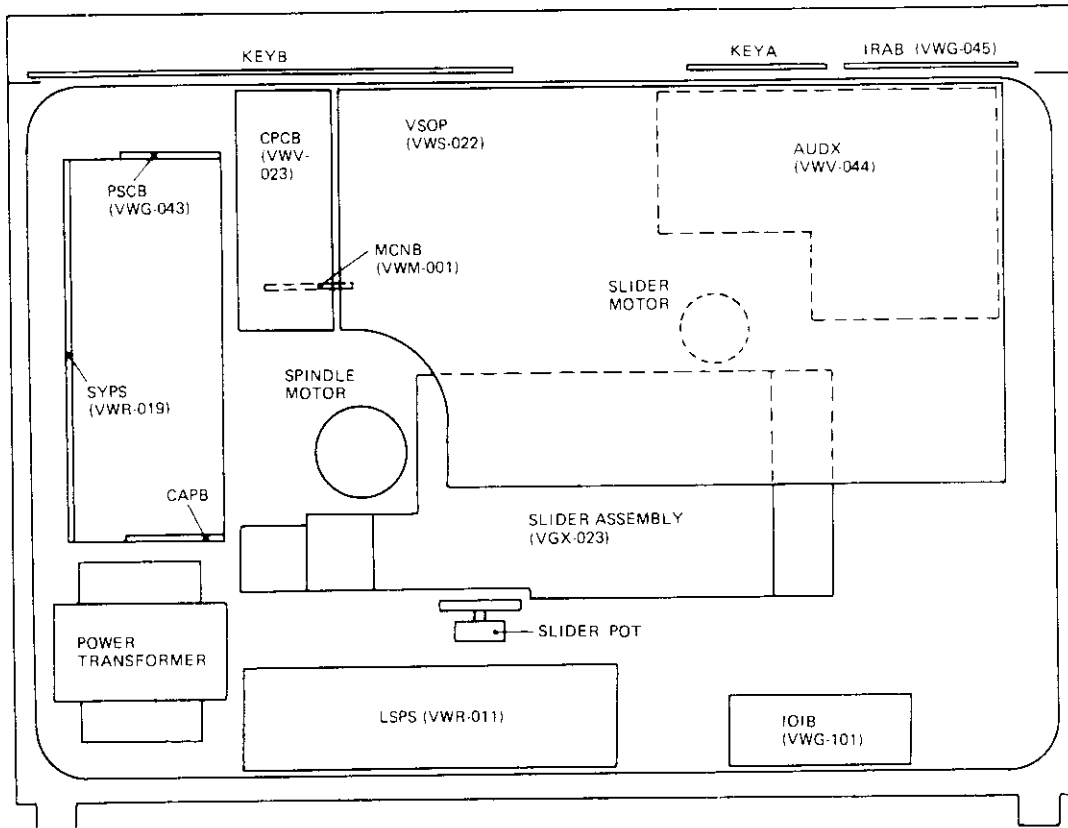

1 2 3

OVERALL CONNECTIONS

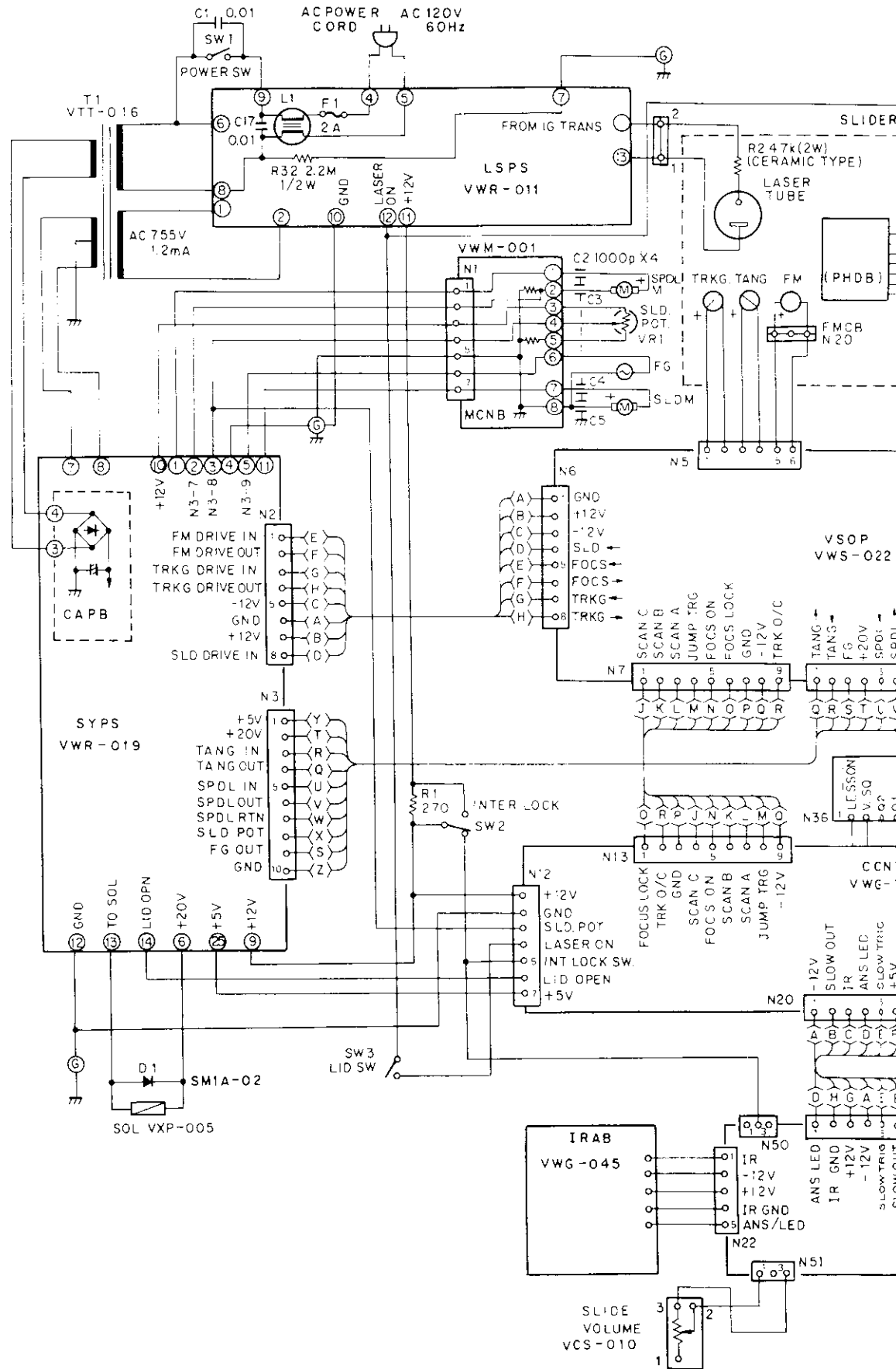

A

B

C

D

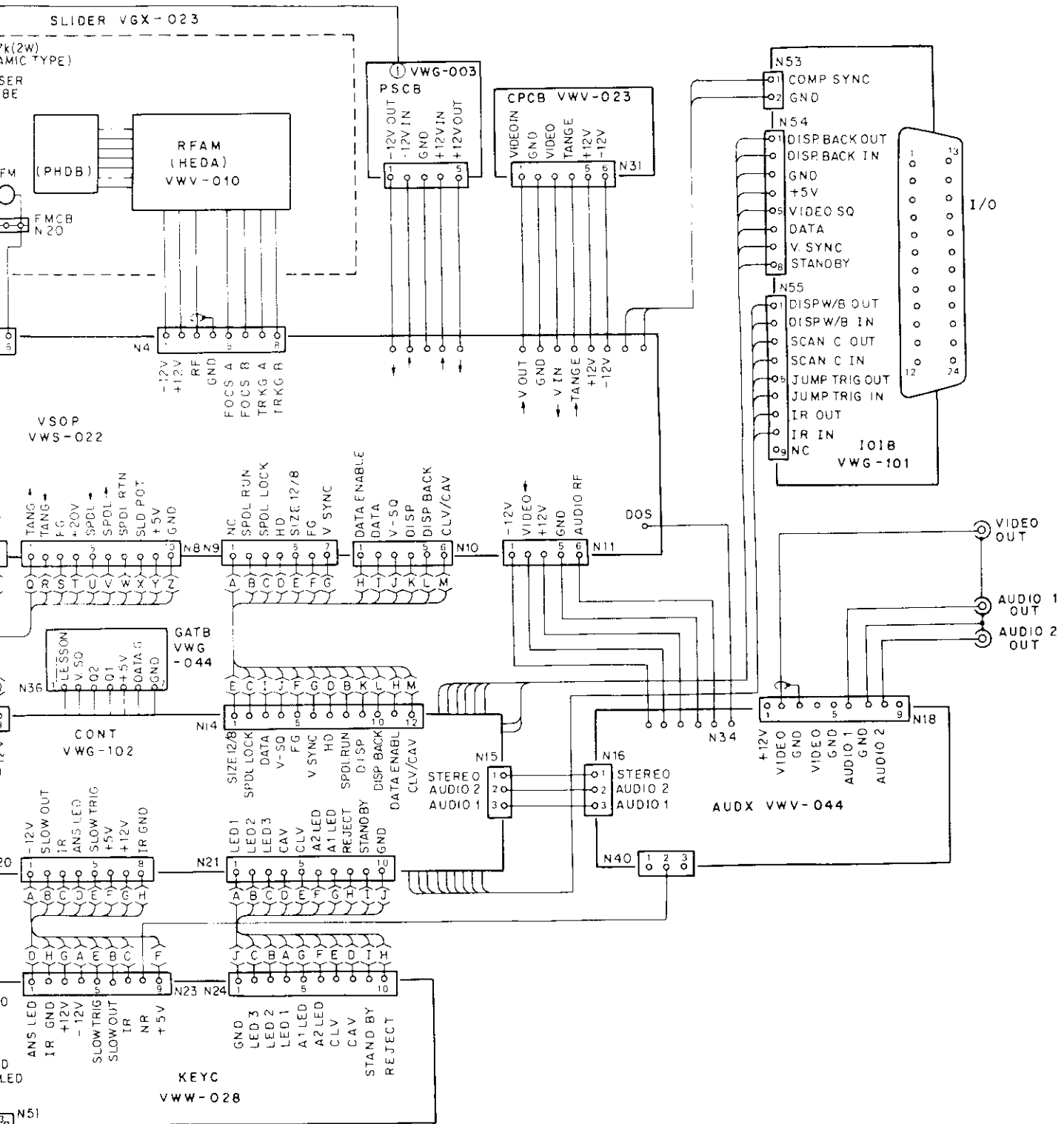

A

B

C

D

SYPS (VWR-019)

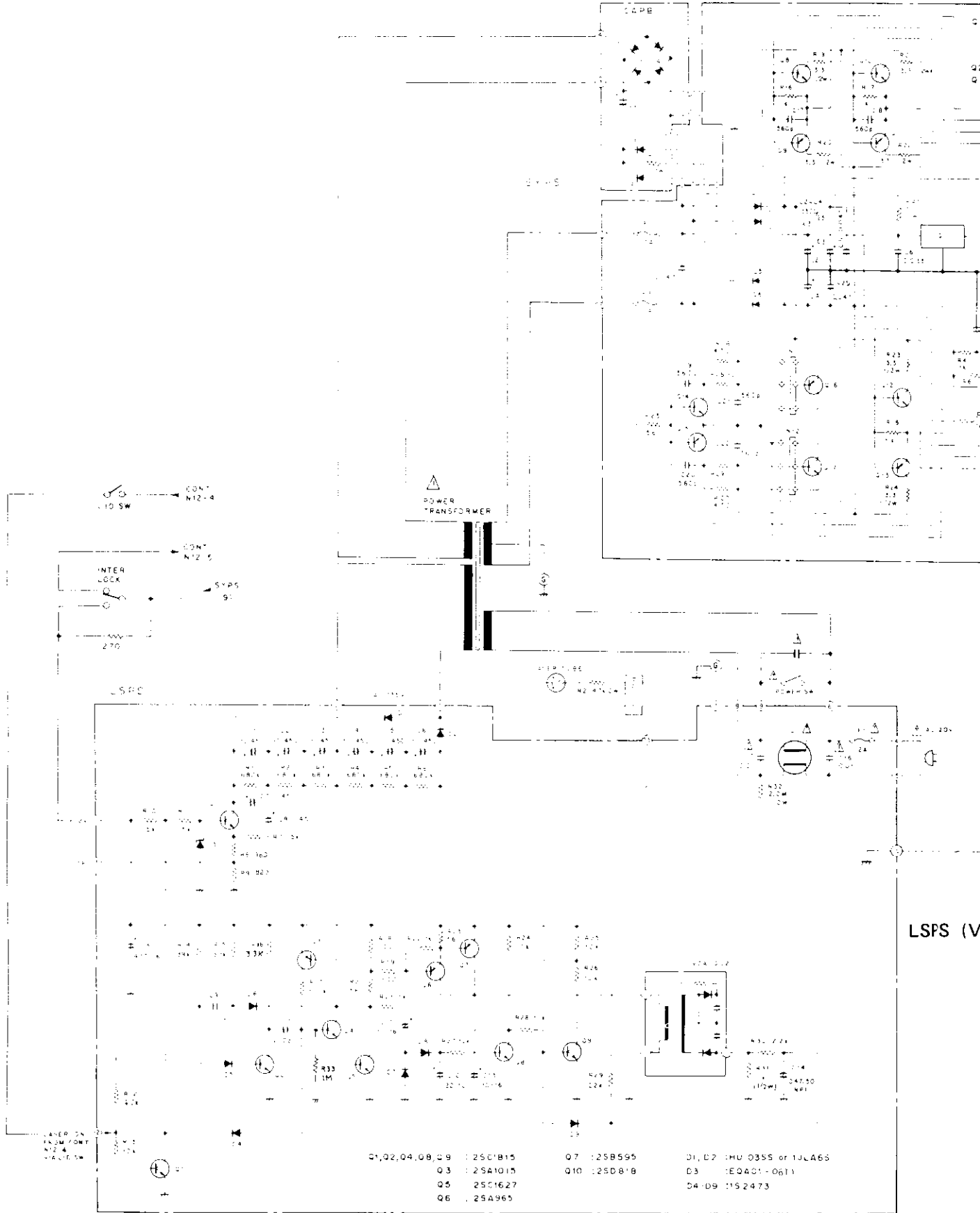

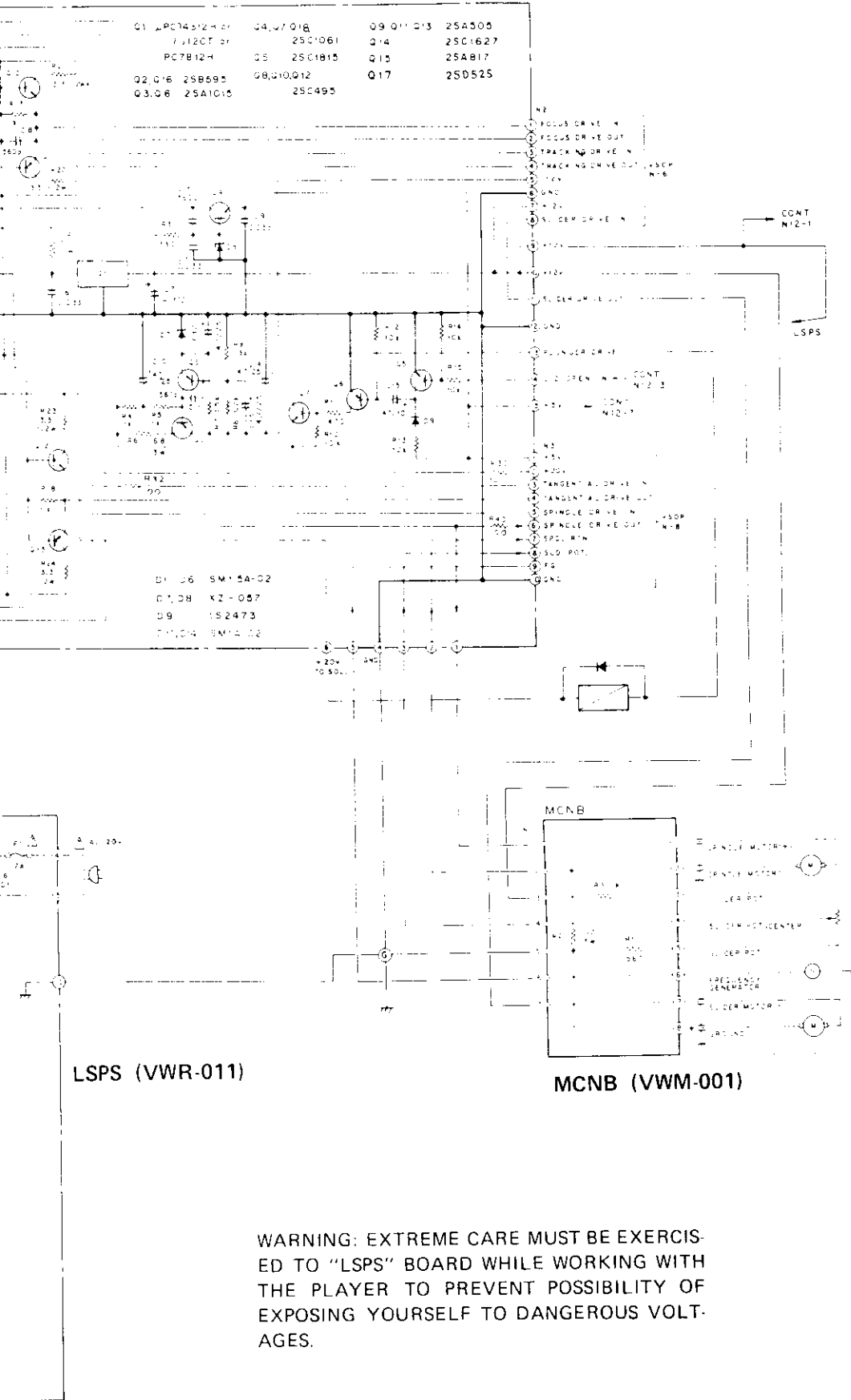

μPC14312H
μPC7812H



A

2SA965

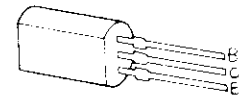

2SD818

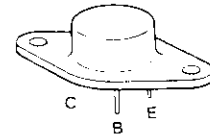

B

25B595
25C1061

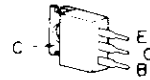

C

25C1627
25A817
25C2320



25A505
25C495

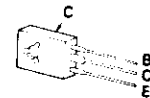

25A1015
25C1815



D

LSPS (VWR-011)

MCNB (VWM-001)

WARNING: EXTREME CARE MUST BE EXERCISED TO "LSPS" BOARD WHILE WORKING WITH THE PLAYER TO PREVENT POSSIBILITY OF EXPOSING YOURSELF TO DANGEROUS VOLTAGES.

SYPS(VWR-019) Parts list 1

(MK)(Part No.)	(IT)(REF Nos. & DESCRIPTIONS)
UPC7812H	Z 1
2SB595-0/Y	Q 2, 16
2SA1015-0/Y/GR	Q 3, 6
2SC1061-B/C	Q 4, 7
2SC1815-0/Y/GR	Q 5
2SC495-0/Y	Q 8, 10, 12
2SA505-0/Y	Q 9, 11, 13
2SC1627-0/Y	Q 14
2SA817-0/Y	Q 15
2SD525-0/Y/GR	Q 17
SM1.5A-02	D 1- 6
XZ-057 (RDS.6EB2)	D 7, 8
1S2473	D 9
SM1A-02	D 11- 14
RD1/4PM000J	R 3- 5, 7- 18, 25- 29, 32, 40
VCN-016	R 6 6.8/3W
RD1/2VS3R3J	R 19- 24
VCN-004	R 30 10/3W
VCN-009	R 41,101 1.2/3W
CKDYF473Z50	C 1, 5, 25
VCH-009	C 2- 4 3300/25
CKDYF333Z50	C 6, 8, 9
CEA4R7M25	C 7, 12- 14
CEA470M25	C 10
CKDYB561K50	C 11, 16- 22
CEA470M10	C 15
CEA222M10	C 101
VEK-006	FU 2, 3 Fuse 3A
VKR-001	Fuse holder
VKP-060	Conn.cords Q16
VKP-061	Conn.cords Q17
VEC-028	Spacer
VEC-002	Insulator/round
VEC-072	Insulator/square
VBA-003	Screw

LSPS(VWR-011) Parts list 1

(MK)(Part No.)	(IT)(REF Nos. & DESCRIPTIONS)
2SC1815-0/Y/GR	Q 1, 2, 8, 9
(2SC2320-E/F)	
(2SC2603-E/F)	
2SA1015-0/Y/GR	Q 3
2SC1815-0/Y	Q 4
2SC1627-0/Y	Q 5
2SA965-0/Y	Q 6
2SB595-0/Y	Q 7
2SD818	Q 10
1JLA6S	D 1, 2
(GHV-03SSN)	
EQA01-06TI	D 3
1S2473	D 4- 9
RD1/4PM000J	R 1- 8, 10- 30
RN1/4PR8200F	R 9
RD1/2VS000J	R 31, 32
VCH-003	C 1- 6
VCH-010	C 7, 8
CKDYB102K50	C 9
CCDSL221J50	C 10
CEA100M16	C 11, 13
CEA220M10	C 12
CEAR47M50NP	C 14
CEA471M16	C 15
VCG-018	C 17
VTL-004	L 1 Line filter
(VTL-003)	
VEK-004	FU 1 Fuse 2A
VKR-001	Fuse holder
VDA-005	H.V. cord
VKN-049	H.V. cap
VCA-004	I.G. block
(VCA-002)	

MCNB(VWM-001) Parts list 1

(MK)(Part No.)	(IT)(REF Nos. & DESCRIPTIONS)
RD1/4PM000J	R 1, 3
VCN-018	R 2 1.2/5W

1

2

3

Q12 ~ Q15

Q11

Q10 Q16 Q17 Q9

Q8

Q2

Q3

CONT

A

B

C

D

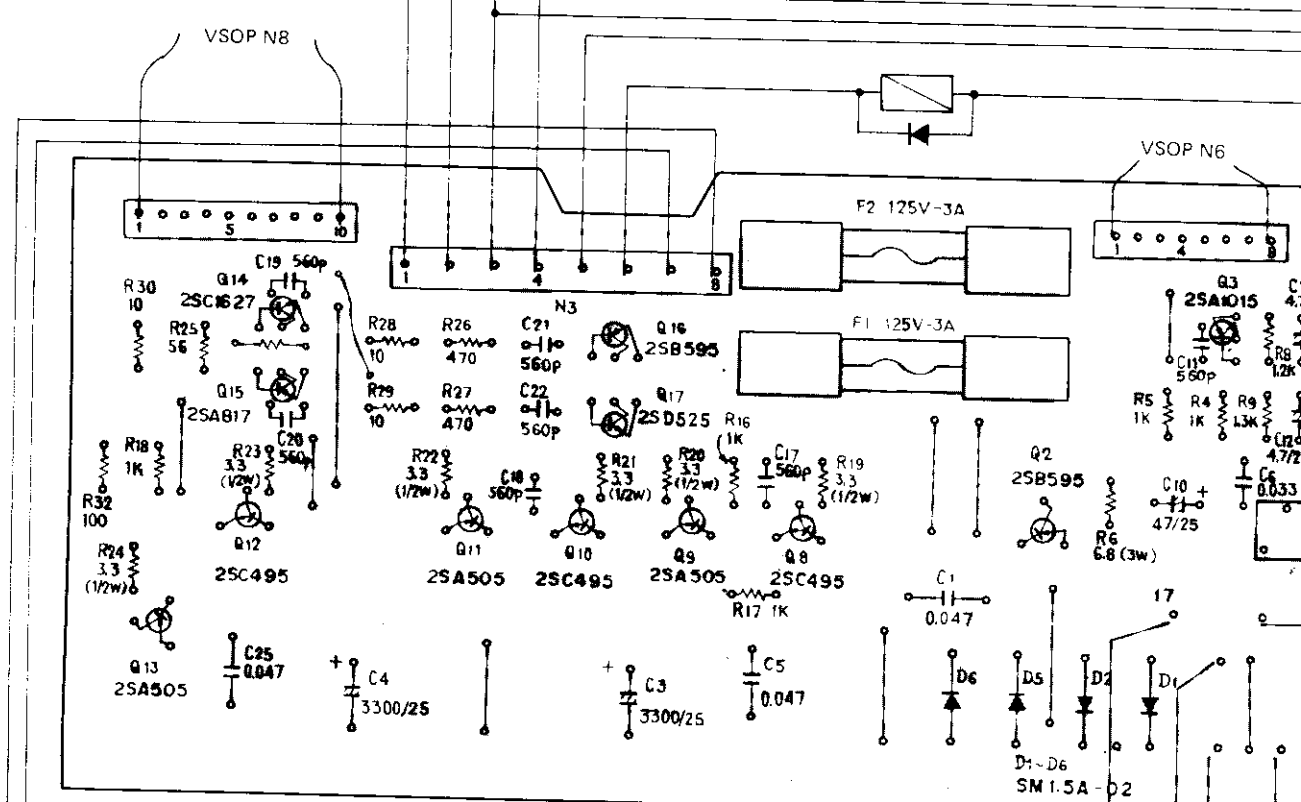

SYPS

LSPS

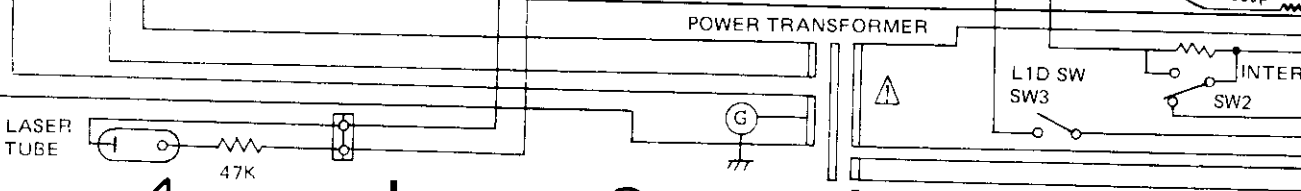
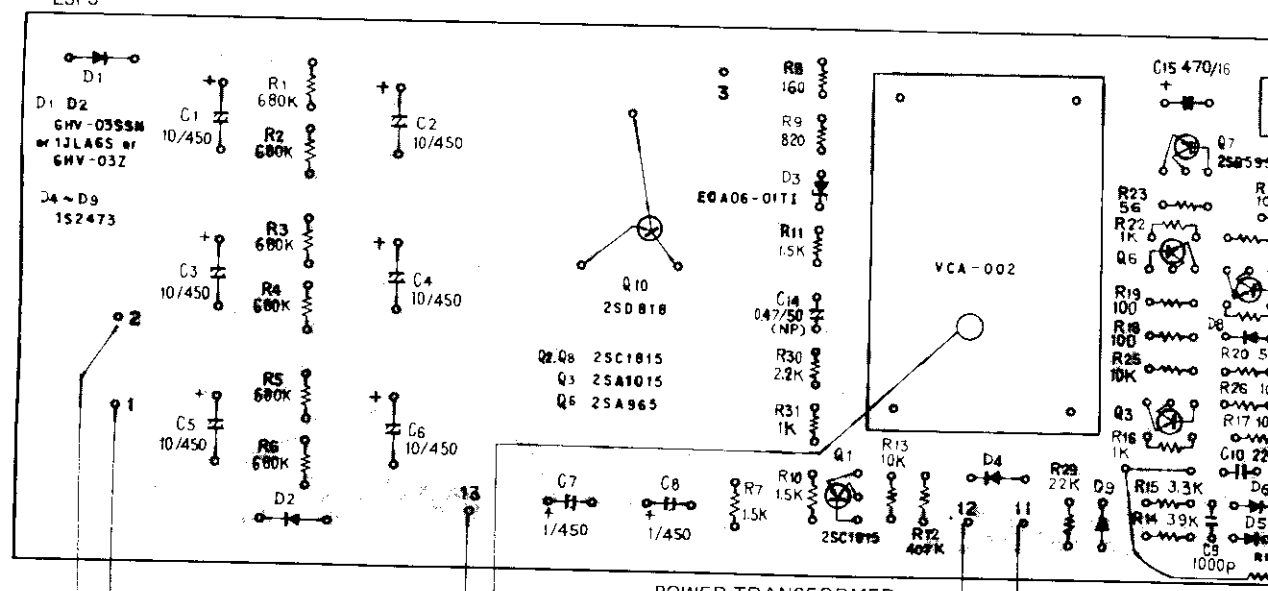

1

2

3

79

Q3 Q1 Q6 Q7 Q4 Q5 Q18

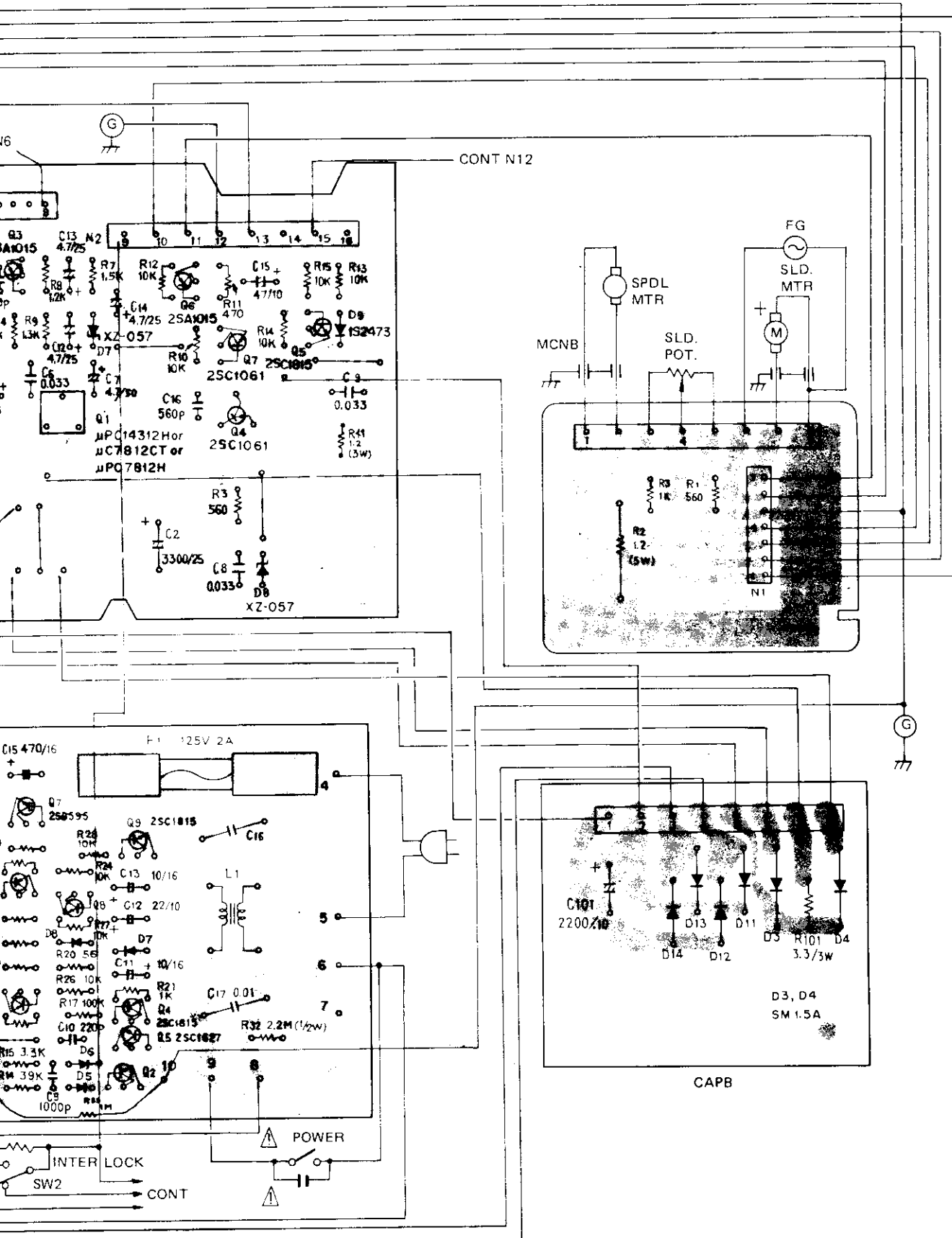

A

B

C

D

11-3 RFAM

A

B

C

D

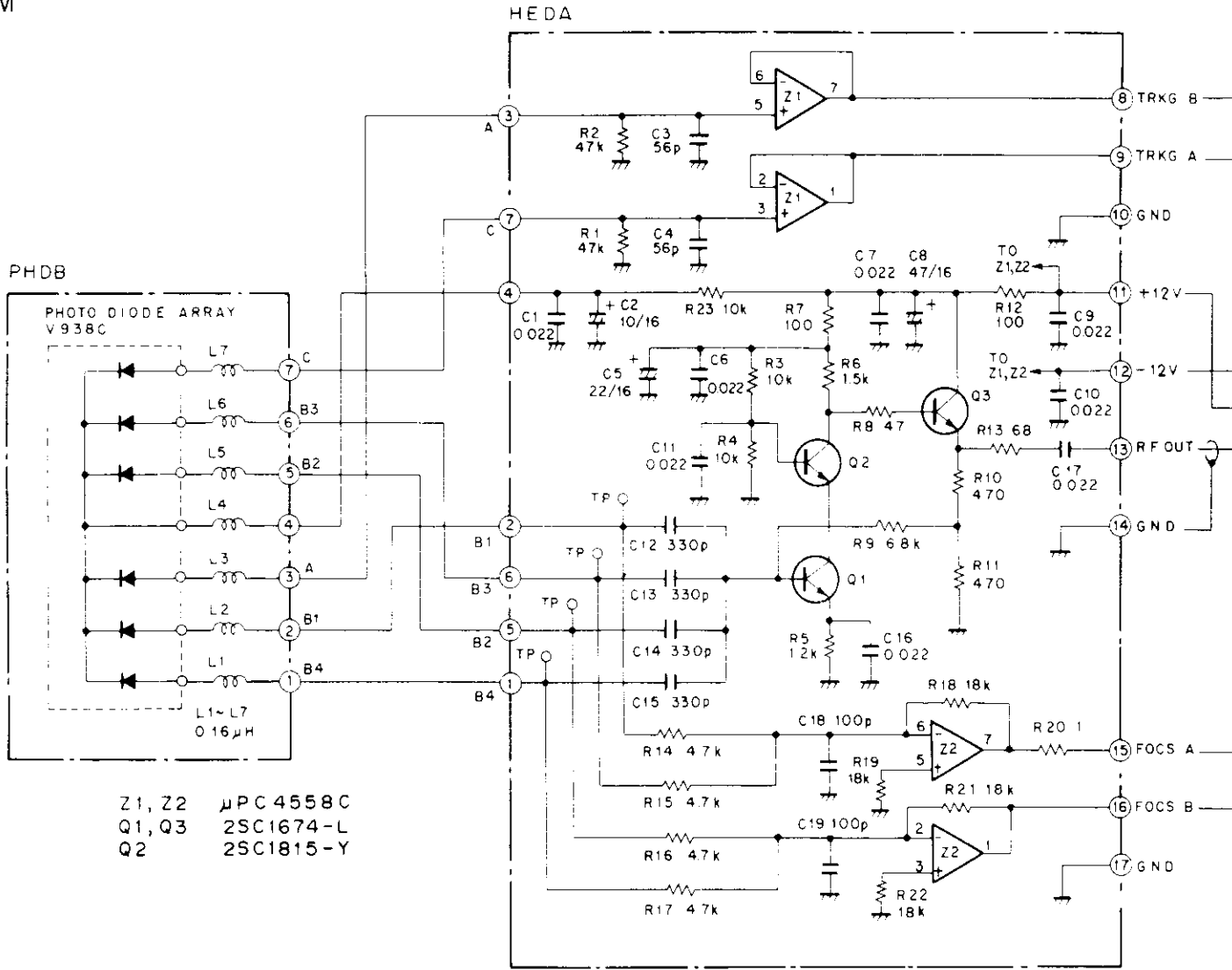

Z1, Z2 μ PC4558C
 Q1, Q3 2SC1674-L
 Q2 2SC1815-Y

RFAM(VWV-010) Parts list 1

(MK)(Part No.)	(IT)(REF Nos. & DESCRIPTIONS)
UPC4558C	Z 1, 2
2SC1674-L/K (2SC2786-L/K)	Q 1, 3
2SC1815-Y	Q 2
RD1/4PM000J	R 1- 17, 19, 20, 22, 23
RN1/4PR1802F	R 18, 21
CKDYF223Z50	C 1, 6, 7, 9- 11, 16, 17
CEA100M16	C 2
CCDSL560J50	C 3, 4
CEA220M16	C 5
CEA470M16	C 8
CCDSL331K50	C 12- 15
CCDSL101J50	C 18, 19
VTF-011	L 1- 7
VKP-072	Conn.cords

4

5

6

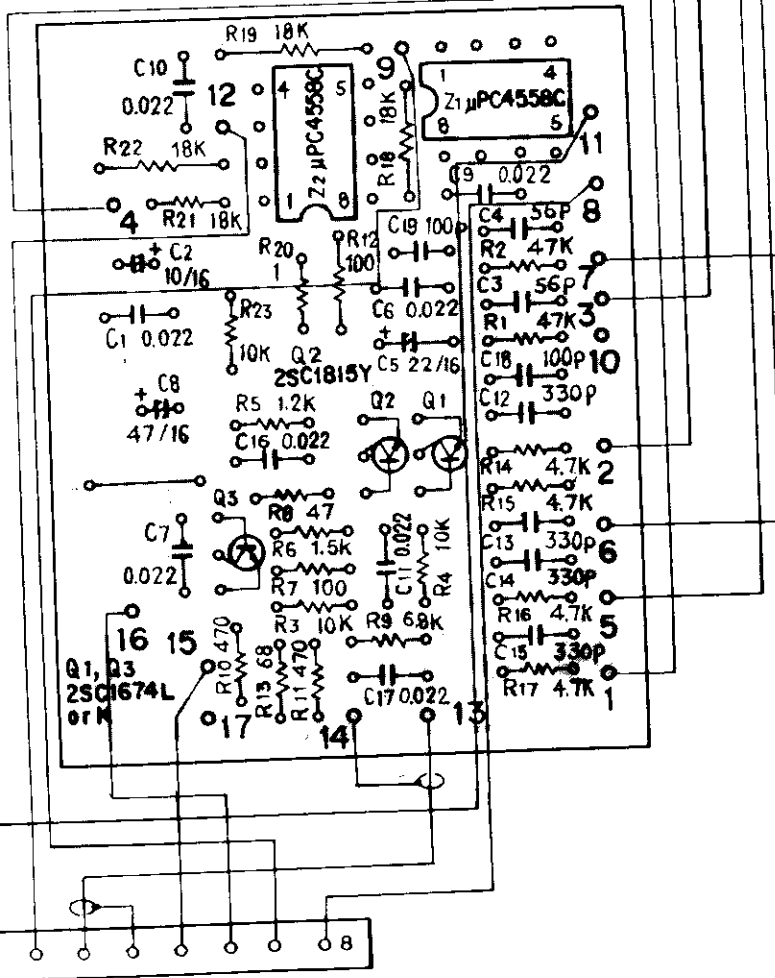
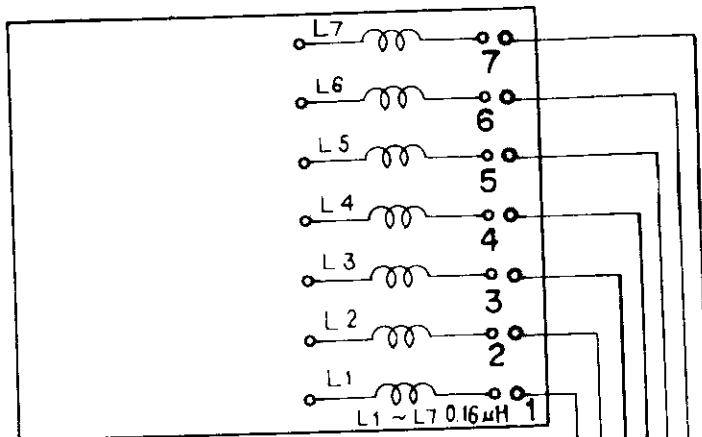
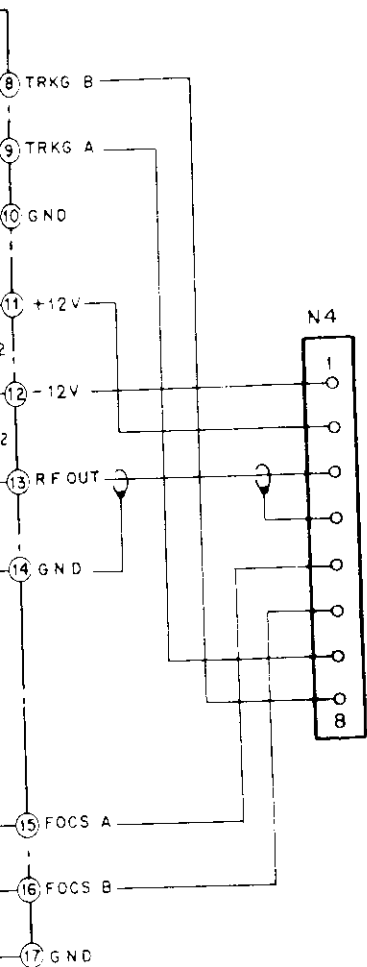

A

B

C

μ PC4558C

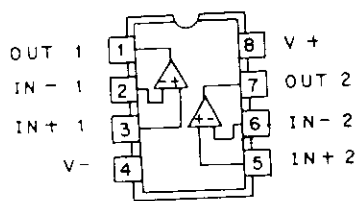

2SC1815



2SC2786

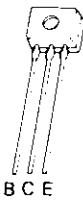

2SC1674



D

4

5

6

VSOP (VWS-022) FTS SECTION

A

B

C

D

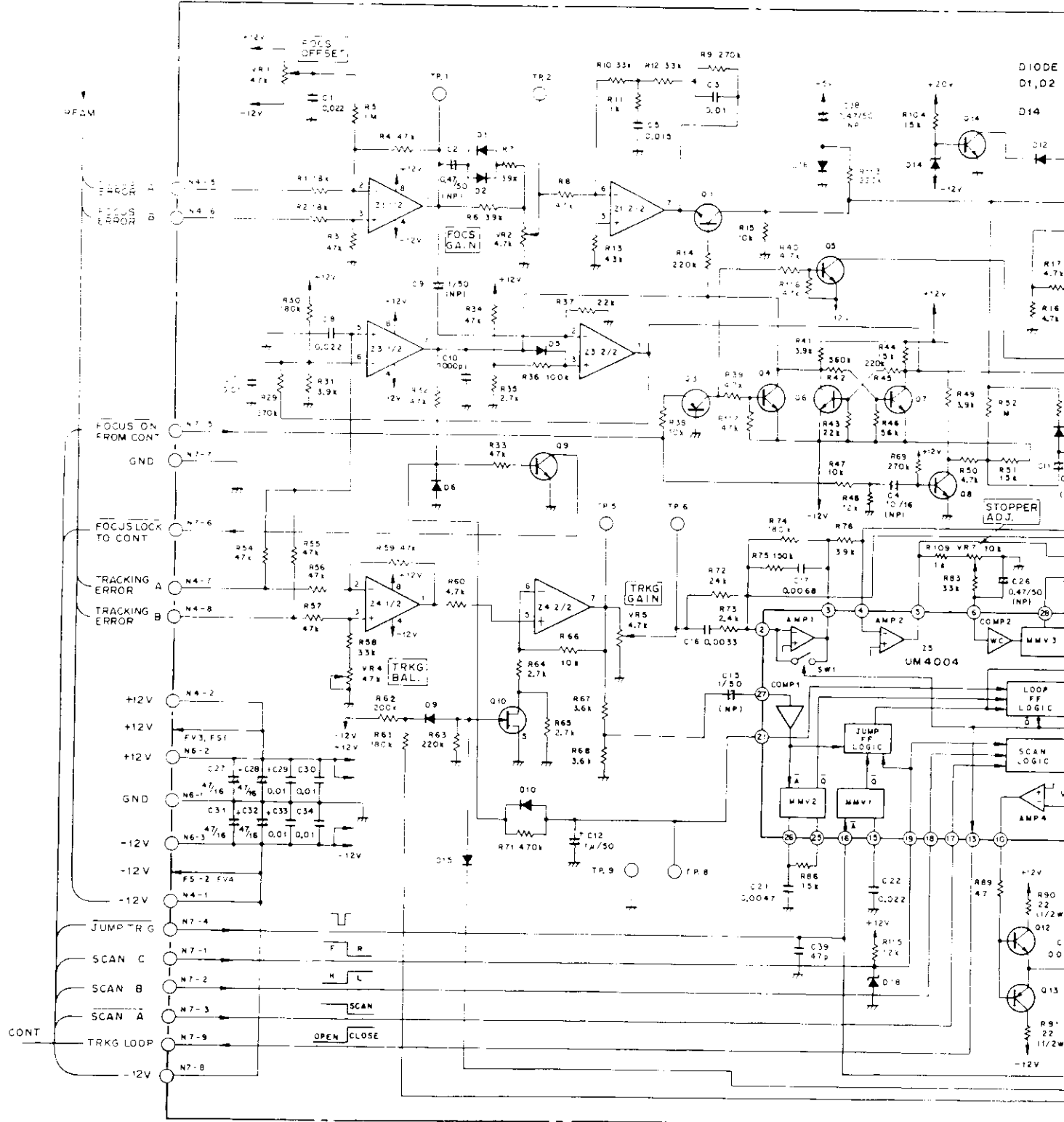

1

2

3

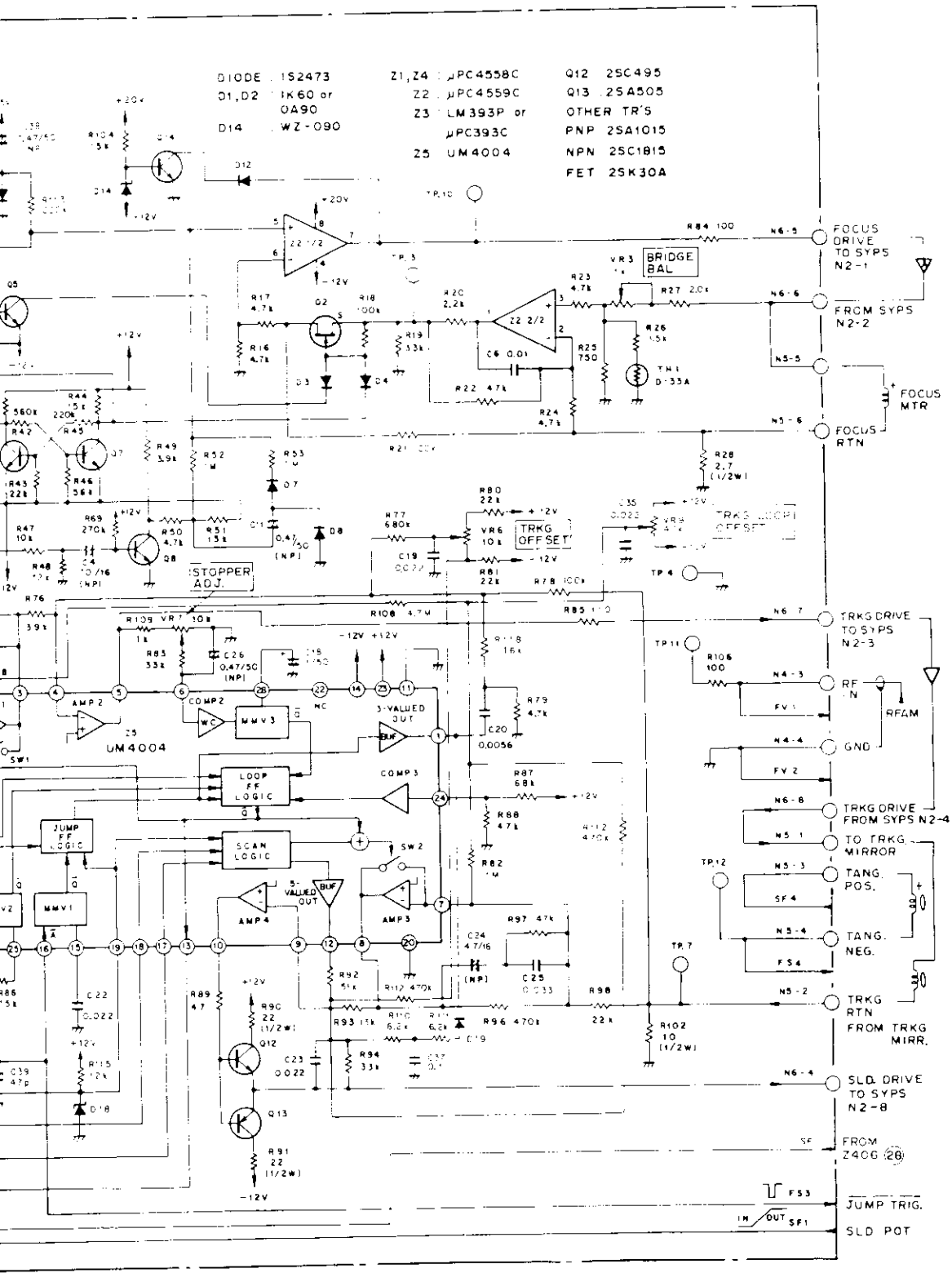

μ PC4558C NJM4558D

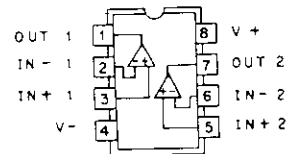

μ PC393C LM393P

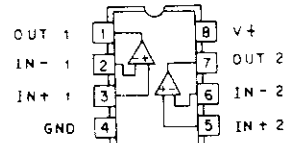

UM4004

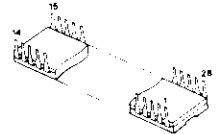

2SA505 2SC495

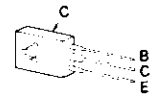

2SA1015 2SC1815



2SK30A



VSOP (VWS-022) SPDL, TANG SECTION

UNLESS OTHER WISE SPECIFIED
 NPN TRS 25C1815
 PNP TRS 25A1015
 FETS 25K30A
 DIODES 152473

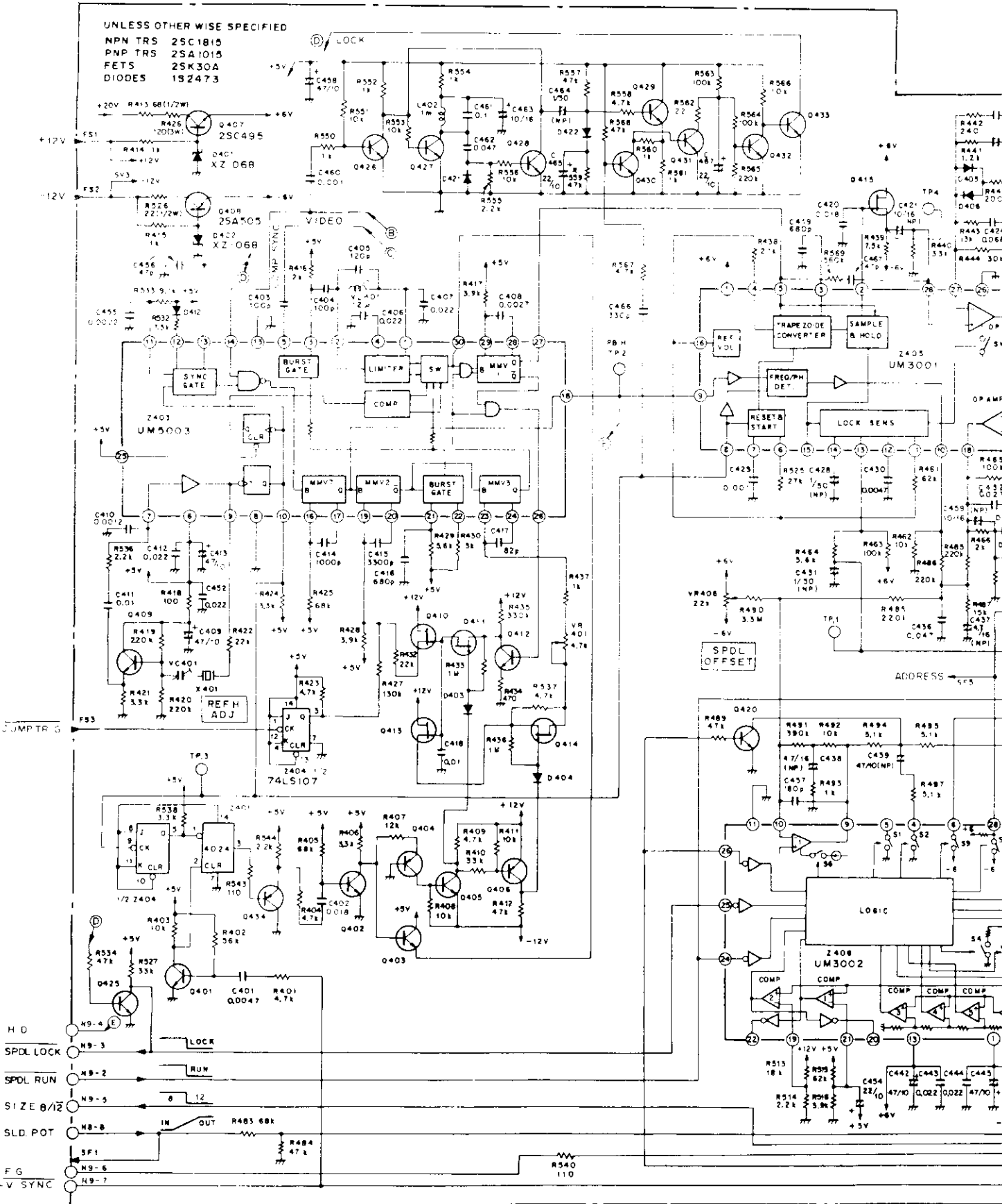

A

B

C

D

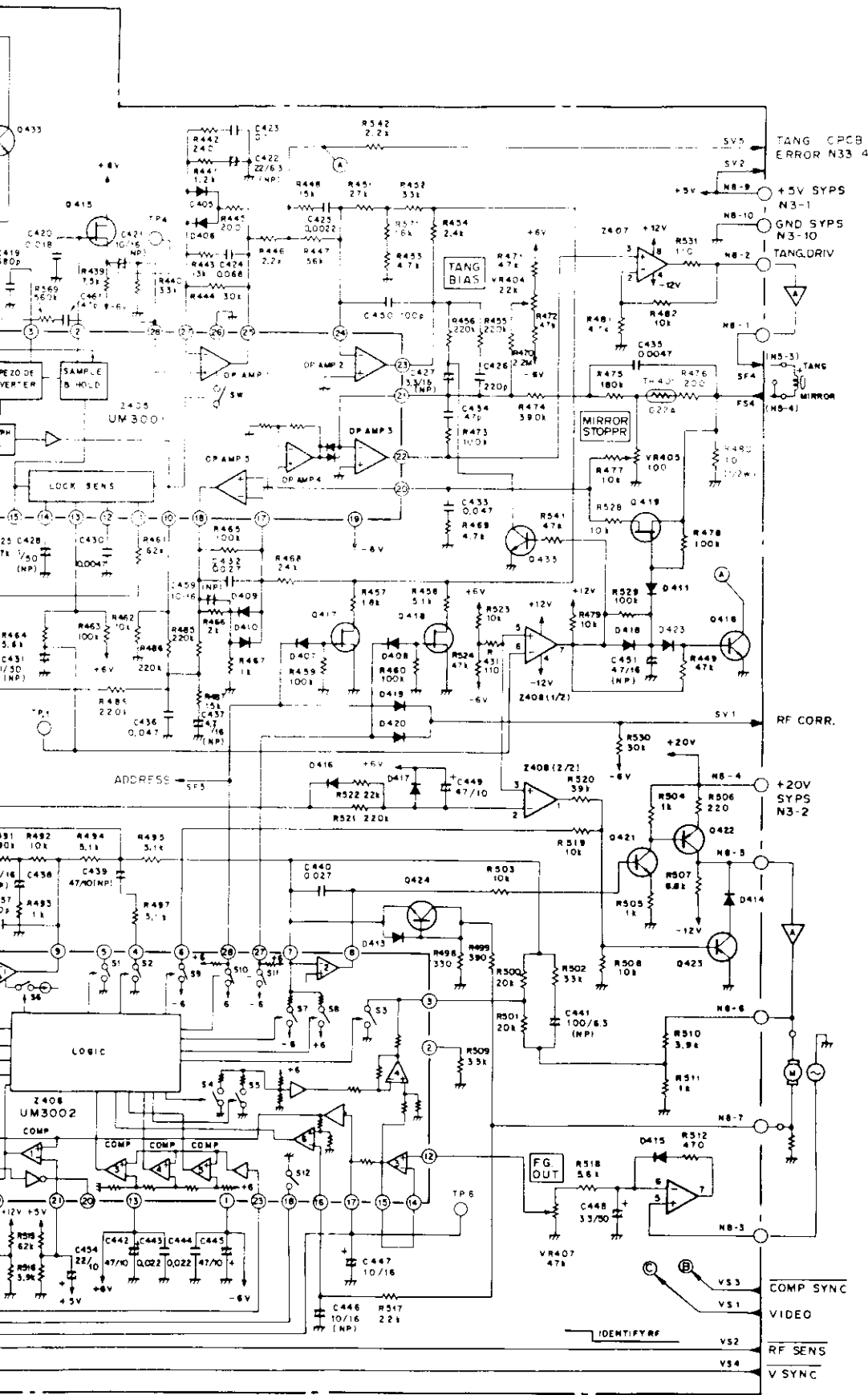

UM5003

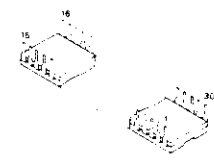

UM3001



UM3002

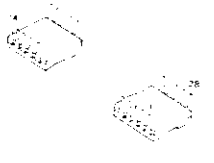

TC4024BP

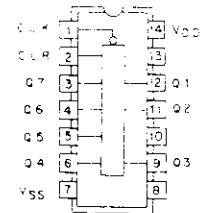

SN74LS107AN

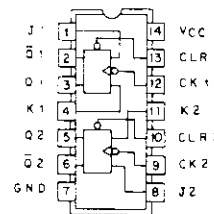

μPC393C

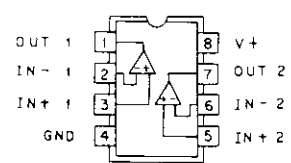

2SA1015
2SC1815



2SK30A



1

2

3

A

PSCB (VWG-043)

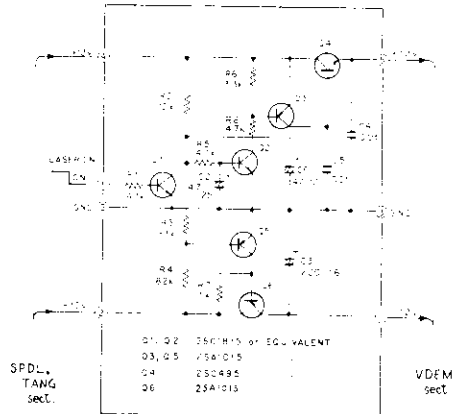

CPCB (VWG-043)

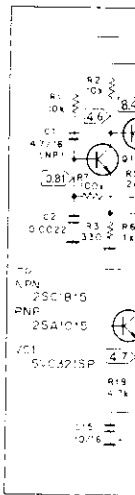

B

VSOP (VWS-022) VDEM SECTION

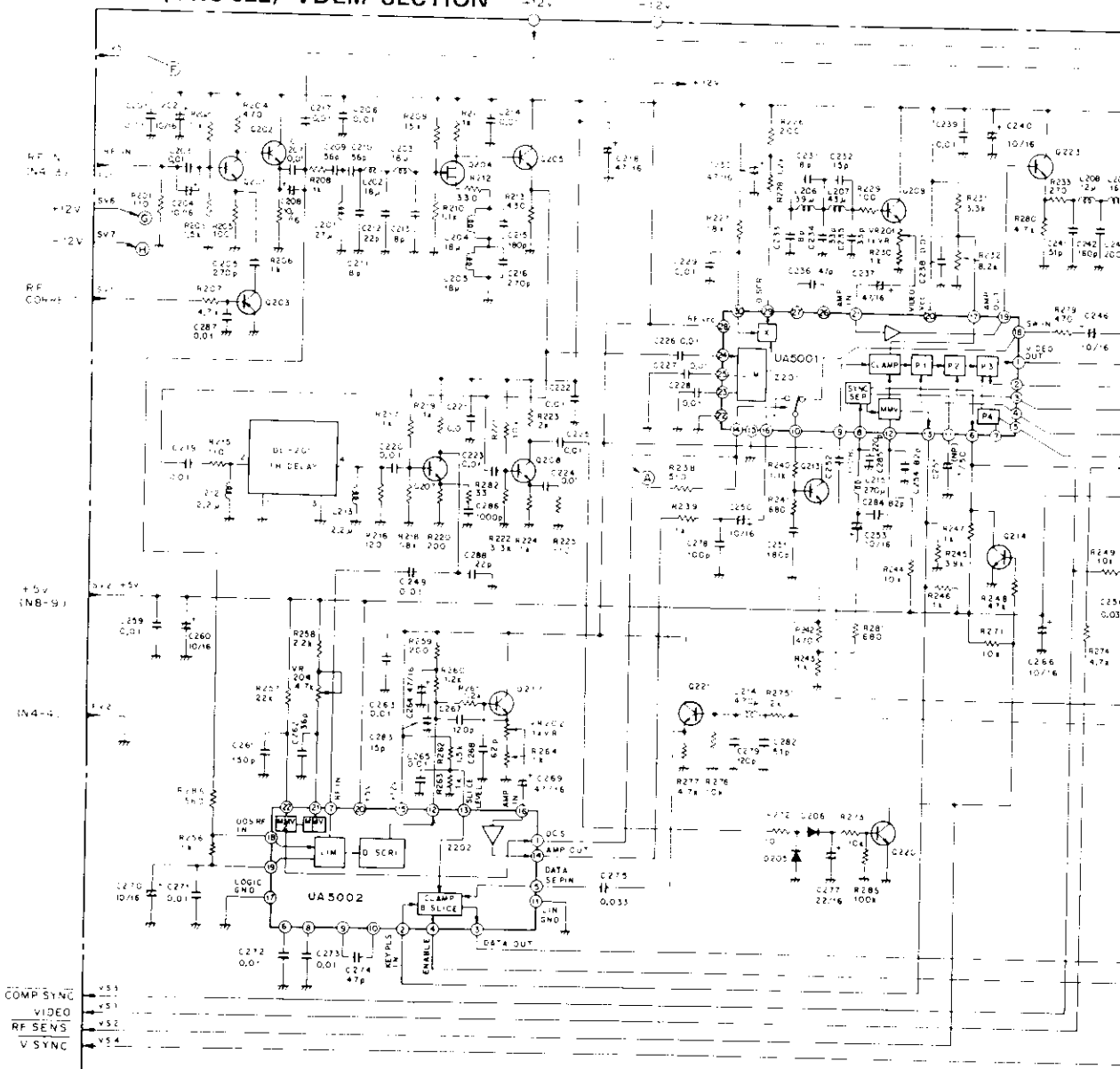

C

D

1

2

3

4

5

A

B

C

CPCB (VWV-023)

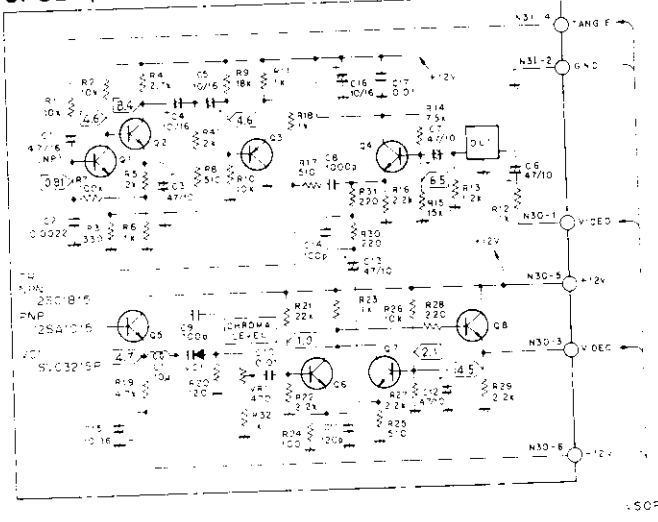

15CP

UA5001

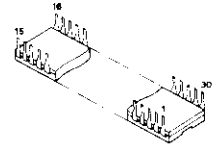

UA5002

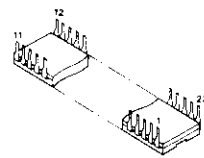

2SA1015
2SC1815



2SK19TM

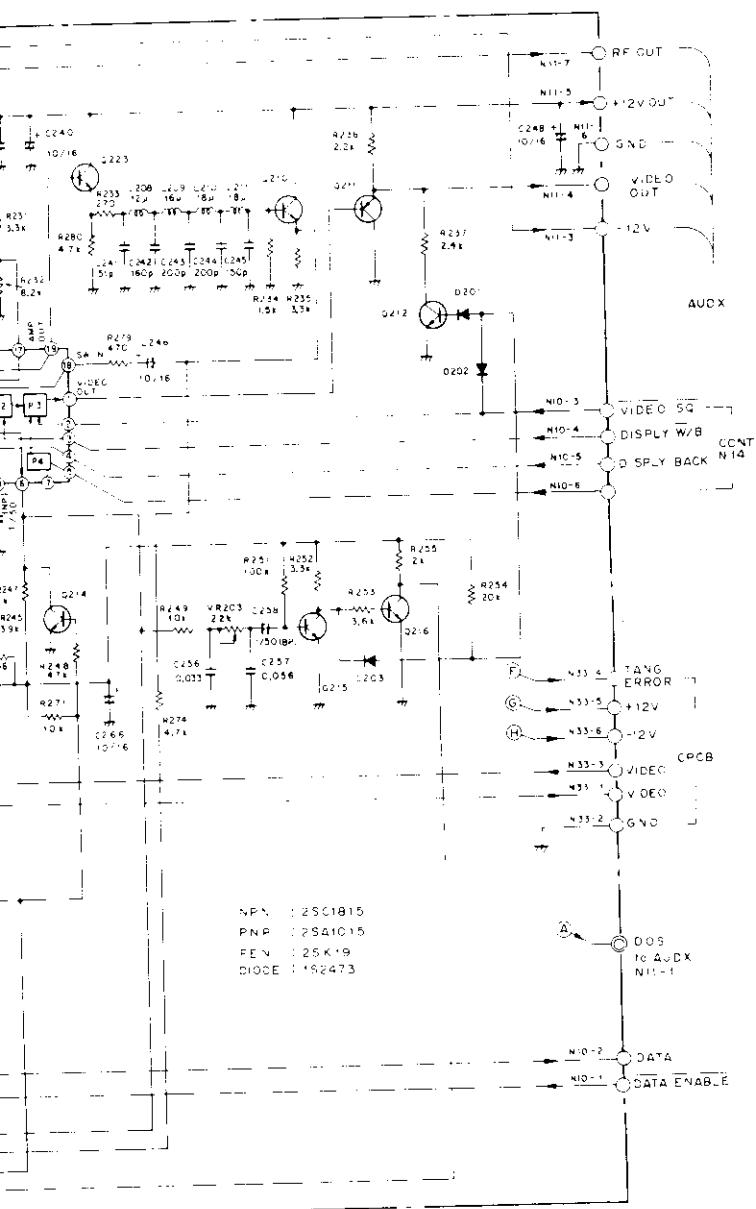

AUCX

CPCB

005
to AUCX
N11-1

3

87

4

5

6

88

VSOP(VWS-022) Parts list

1

(MK)(Part No.) (IT)(REF Nos. & DESCRIPTIONS)

UPC4558C (NJM4558D)	Z	1, 4,407
UPC4559C	Z	2
UPC393C (LM393P)	Z	3,408
UM4004	Z	5
UA5001	Z	201
UA5002	Z	202
TC4024BP (MB84024BM)	Z	401
UM5003	Z	403
HD74LS107P (SN74LS107AN)	Z	404
UM3001	Z	405
UM3002 (UM3002A)	Z	406
2SK30A-GR/Y	Q	2,410,411,413-415,417-419
2SA1015-O/Y/GR	Q	3,203,211,404,406,422,423, 434
2SC1815-Y/GR	Q	8
2SK30A-Y	Q	10
2SC475-O/Y	Q	12,407
2SA505-O/Y	Q	13,408
2SK19TM-Y (2SK192A-Y)	Q	204
2SC1815-O/Y/GR	Q	217,221,424,433
2SC2320-E/F (2SC2603-E/F)	Q	217,433
1K60 (0A90-R)	D	1, 2
1S2473	D	3- 10, 12, 15, 16,201-203, 205,206,403-423
WZ-090	D	14
WZ-048	D	18
RD6-8EB3 (XZ-068) (EQA01-07R2)	D	401,402
RD1/4PM000J	R	1- 27, 29- 33, 36- 69, 71- 89, 92- 94, 96- 98,104,106, 108,109,111,112,115-118,201, 203-210

VSOP(VWS-022) Parts list

2

(MK)(Part No.) (IT)(REF Nos. & DESCRIPTIONS)

RD1/2VS2R7J	R	28
RD1/2VS000J	R	90, 91,102,413,480,526
RD1/4PM000J	R	211-213,215-249,251,252,254- 264,271,273-277,279-282,285, 286,401-425,427-429,431-449
VCN-020	R	426 120/3W
RD1/4PM000J	R	451-479,481-495,497-512,515- 525,527-534,536-538,540,542, 544,550-566,568,569,571,753
RN1/4PR0000F	R	513,514
VCP-029	VR	1, 4, 9,407 47k
VCP-026	VR	2, 5,204,401 4.7k
VCP-024	VR	3,201,202 1k
VCP-027	VR	6, 7 10k
VCP-028	VR	203,404,406 22k
VCP-023	VR	405 470
CKDYF223Z50	C	1, 8, 19, 23, 35,406,407, 412,443,444,452
CEAR47M50NP	C	2, 11, 26, 38
CQMA103J50	C	3,418
CQMA153J50	C	5
CKDYF103Z50	C	6, 7, 29, 30, 33, 34,201, 203,206,207,214,217,219-229, 238,239,247,249,259,263,265, 271-273,287,411
CEA010M50NP	C	9, 15,255,258,428,431,464
CKDYB102K50	C	10,286,460
CEA010M50	C	12, 18
CQMA332J50	C	16,415
CQMA682J50	C	17
CQMA562J50	C	20
CQMA472J50	C	21,401,430,435
CQMA223J50	C	22
CEA4R7M16NP	C	24,437,438,451
CQMA333J50	C	25,256,275
CEA100M16	C	27, 28, 31, 32,202,204,208, 240,246,248,250,253,260,266, 270,277,447,463

VSOP(VWS-022) Parts list

3

(MK)(Part No.)	(IT)(REF Nos. & DESCRIPTIONS)
CQMA104J50	C 37,423
CCDCH470J50	C 39,274,467
CCDSL271J50	C 205,216
CCDCH560J50	C 209,210
CCDCH080D50	C 211,213,231,233
CCDCH220J50	C 212,288
CCDSL181J50	C 215,251,457
CEA470M16	C 218,230,264
CCDCH150J50	C 232
CCDCH330J50	C 234,235
CCDUJ470J50	C 236
CEA470M10	C 237,269,409,413,442,445,449, 458
CCDSL510J50	C 241,282
CCDSL161J50	C 242
CCDSL151J50	C 245,261
CQMA823J50	C 252
CCDSL820J50	C 254,284,417
CQMA563J50	C 257
CCDCH360J50	C 262
CCDSL121J50	C 267,279,405
CCDSL620J50	C 268
CCDSL101J50	C 278,403,404,450
CCDSL150J50	C 283
CCDSL221J50	C 285,426
CQMA183J50	C 402,420
CQMA272J50	C 408
CQMA122J50	C 410
QQSH102J50	C 414
QQSH681J50	C 416,419
CEA100M16NP	C 421,446,459
CEA220M6NP	C 422
CQMA683J50	C 424
CQMA222J50	C 425,455
CEA3R3M16NP	C 427
CQMA102J50	C 429
CQMA273J50	C 432,440
CQMA473J50	C 433,436,462
CCDSL470J50	C 434,456
CEA470M10NP	C 439
CEA101M6NP	C 441
CEA3R3M50	C 448
CEA220M10	C 454,465,467
VCE-007	C 461
CCDSL331J50	C 466
VCM-004 (VCM-005)	VC401 50pF

VSOP(VWS-022) Parts list

4

(MK)(Part No.)	(IT)(REF Nos. & DESCRIPTIONS)
VTL-067 (VTL-051)	L 207 43uH
VTL-063 (VTL-056)	L 209 16uH
VTF-019 (VTF-022)	L 401 12uH
VSS-005 (VSS-010)	X 401 31.5kHz
D33A D22A	TH 1 TH401
VKP-227	Conn.cords
VKP-229	Conn.cords
VKP-228	Conn.cords
VTF-012 (VTF-013) (VTF-030)	DL 201 1H Dly

PSCB(VUG-043) Parts list 1

(MK)(Part No.)	(IT)(REF Nos. & DESCRIPTIONS)
2SC1815-Y/GR (2SC2320-E/F) (2SC2603-E/F)	Q 1, 2
2SA1015-Y/GR 2SC495-O/Y	Q 3, 5, 6 Q 4
RD1/4PM000J	R 1- 8
CEA4R7M25	C 2
CEA221M16	C 3
CKDYF103Z50	C 4, 5
CEA470M10	C 6

CPCB(VUV-023) Parts list 1

(MK)(Part No.)	(IT)(REF Nos. & DESCRIPTIONS)
2SC1740-Q/R/S	Q 1, 2, 4- 8
(2SC1815-O/Y/GR) 2SA1015-O/Y/GR	Q 3
SVC321SP-B1/D1	D 1
RD1/4PM000J	R 1- 32, 41
VCP-023	VR 1 470
CEA4R7M16NP	C 1
CKDYB222K50	C 2
CEA470M10	C 3, 6, 7, 12, 13
CEA100M16	C 4, 5, 15, 16
CKDYB102K50	C 8
CCDSL101J50	C 9, 14
CKDYF103Z50	C 10, 17
CCDSL121J50	C 11
VTL-023 (VTL-061)	L 1 10uH
VTF-032	0.5uS D1y

A

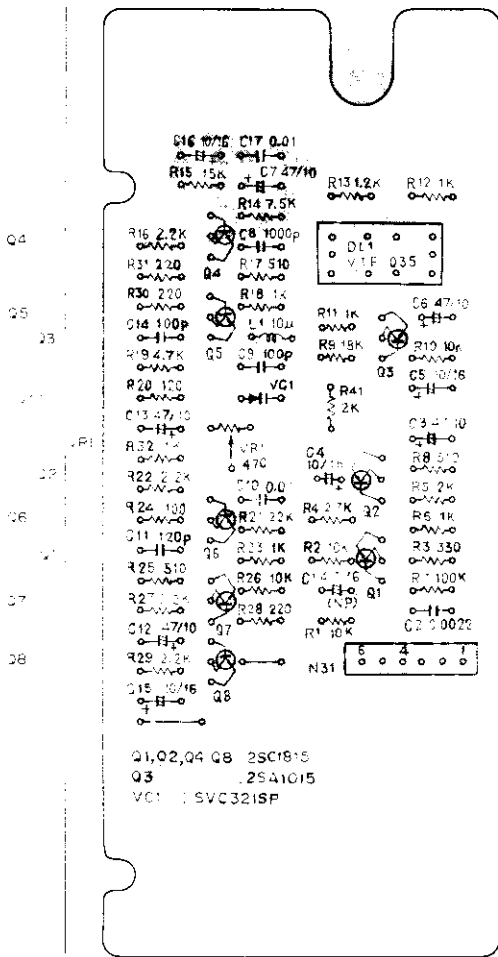

Q4

Q5

Q3

B

Q6

Q7

Q8

B

C

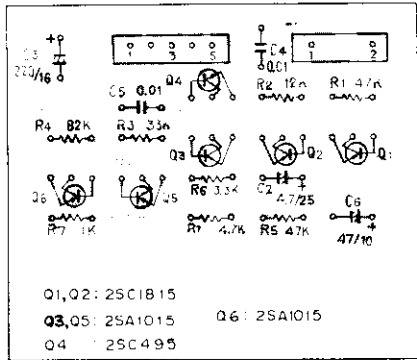

D

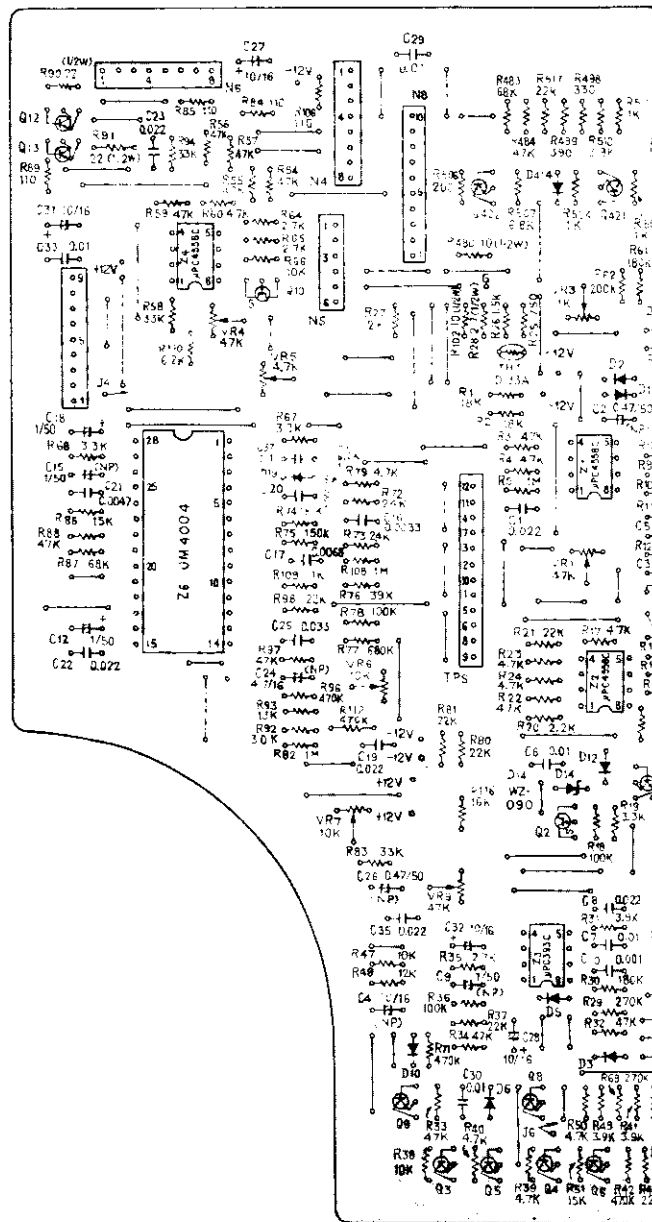
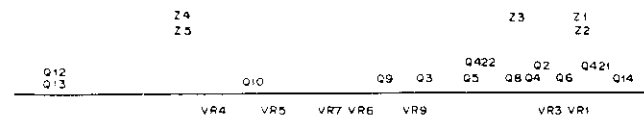

Z3	Z1	Z407	Z408	Z406	Z405	Q405	Z404	Z401	Q409	Z202	Z201	Q205	Q207
Q422	Q2	Q421	Q423	Q424	Q411	Q406	Q403	Q429	Q426	Q221	Q203	Q201	Q204
Q5	Q8	Q4	Q1	Q7	Q410	Q413	Q404	Q402	Q427	Q224	Q215	Q217	Q208
Q14	Q17	Q417-Q419	Q435	Q408	Q407	Q415	Q412	Q425	Q430	Q434	Q430	Q431	Q209
VR3	VR1	VR2	VR403	VR407	VR404	VR401	VR406	VR203	VR202	VR204	VR201		

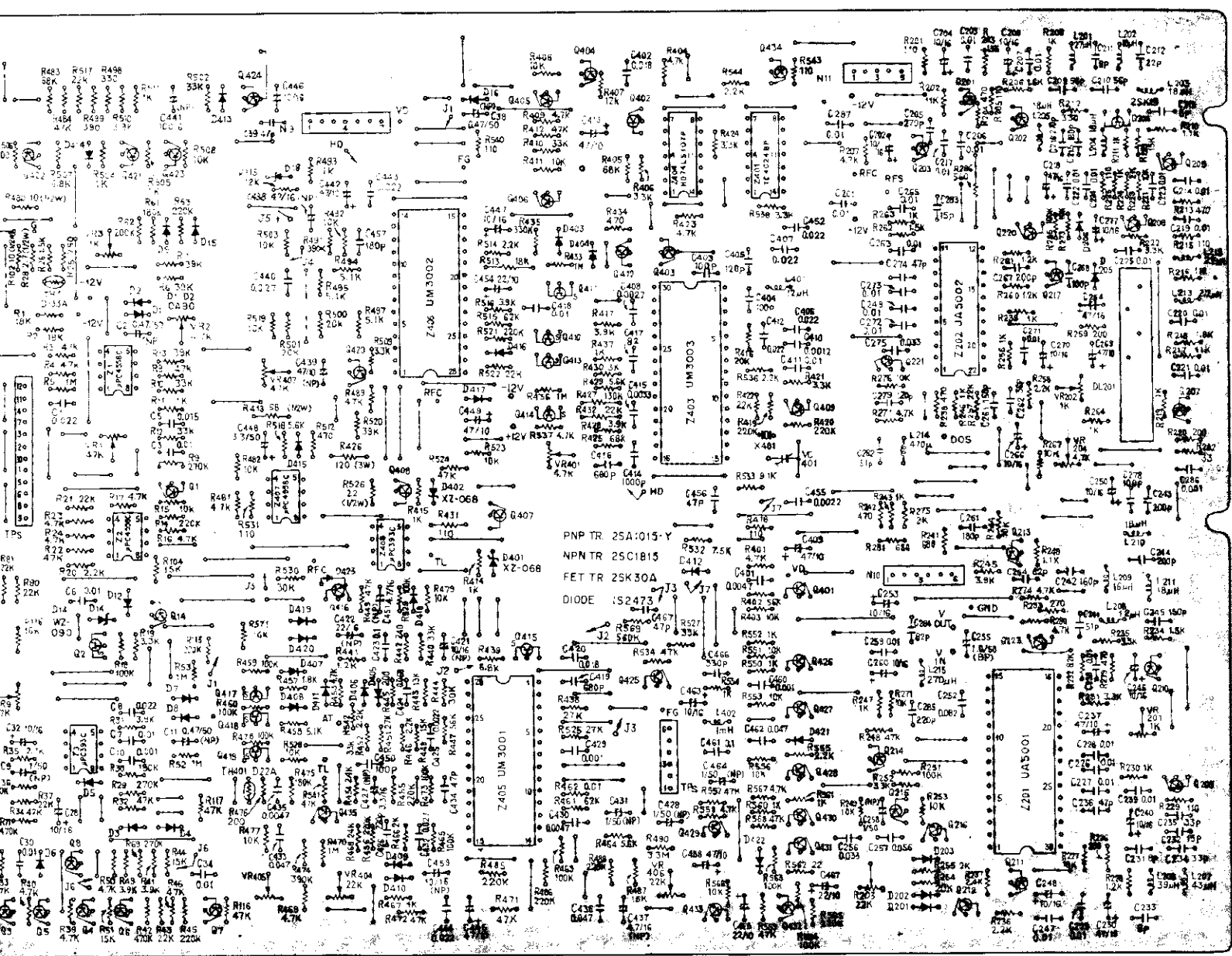

PNP TR 2SA015-Y
 NPN TR 2SC1815
 FET TR 2SK30A
 DIODE 1S2473

11-5 AUDX

AUDX (VWV-044)

A

B

C

D

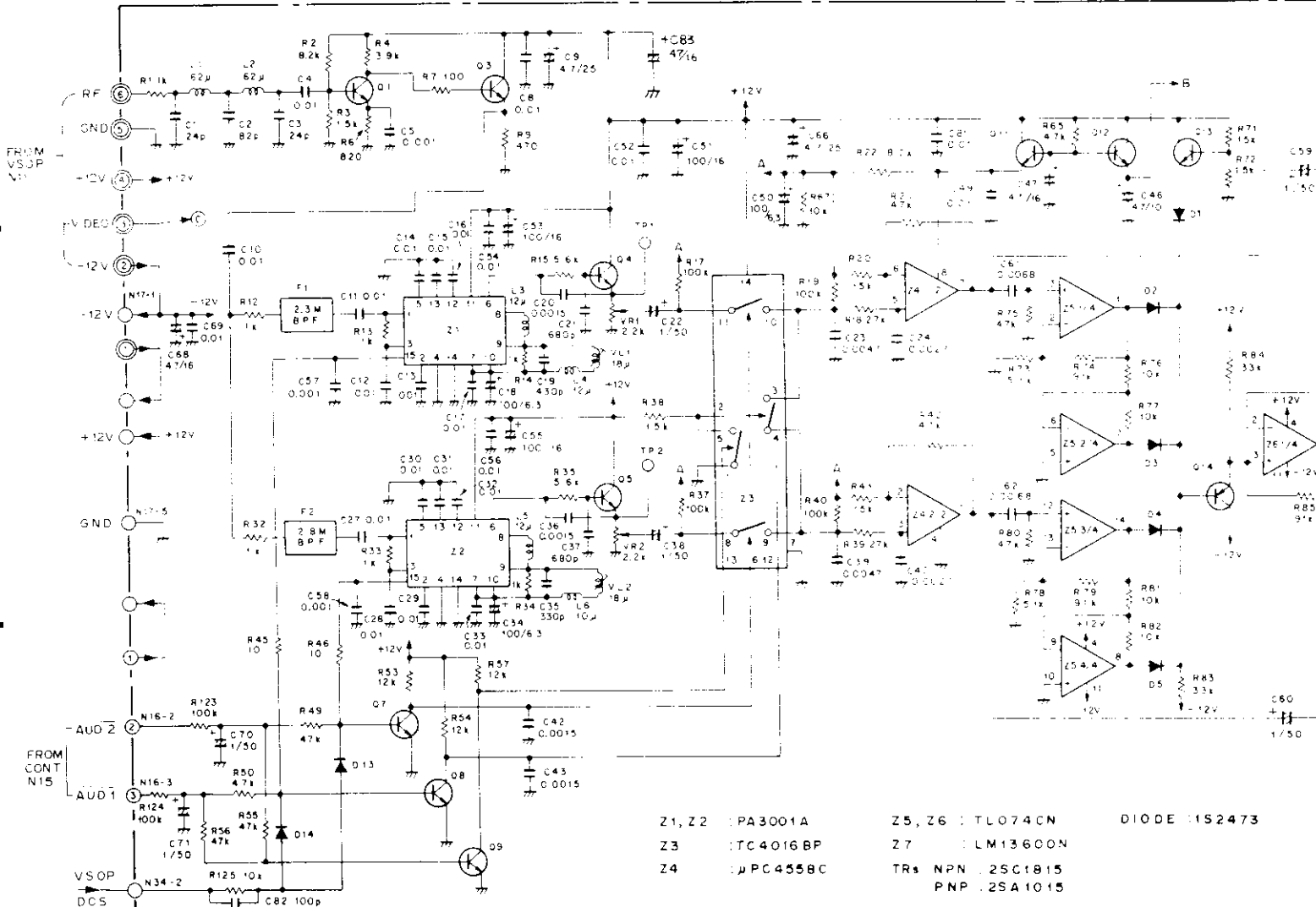

LM13600N

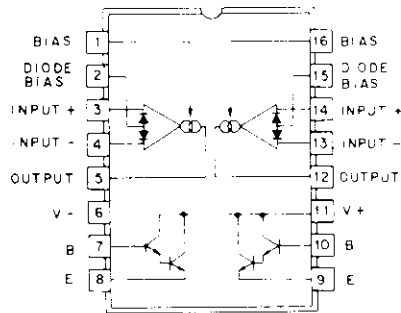

2SA1015
2SC1815



TL074CN
LF347N

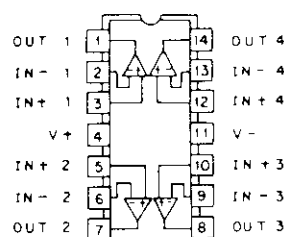

TC4016

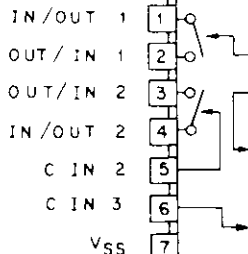

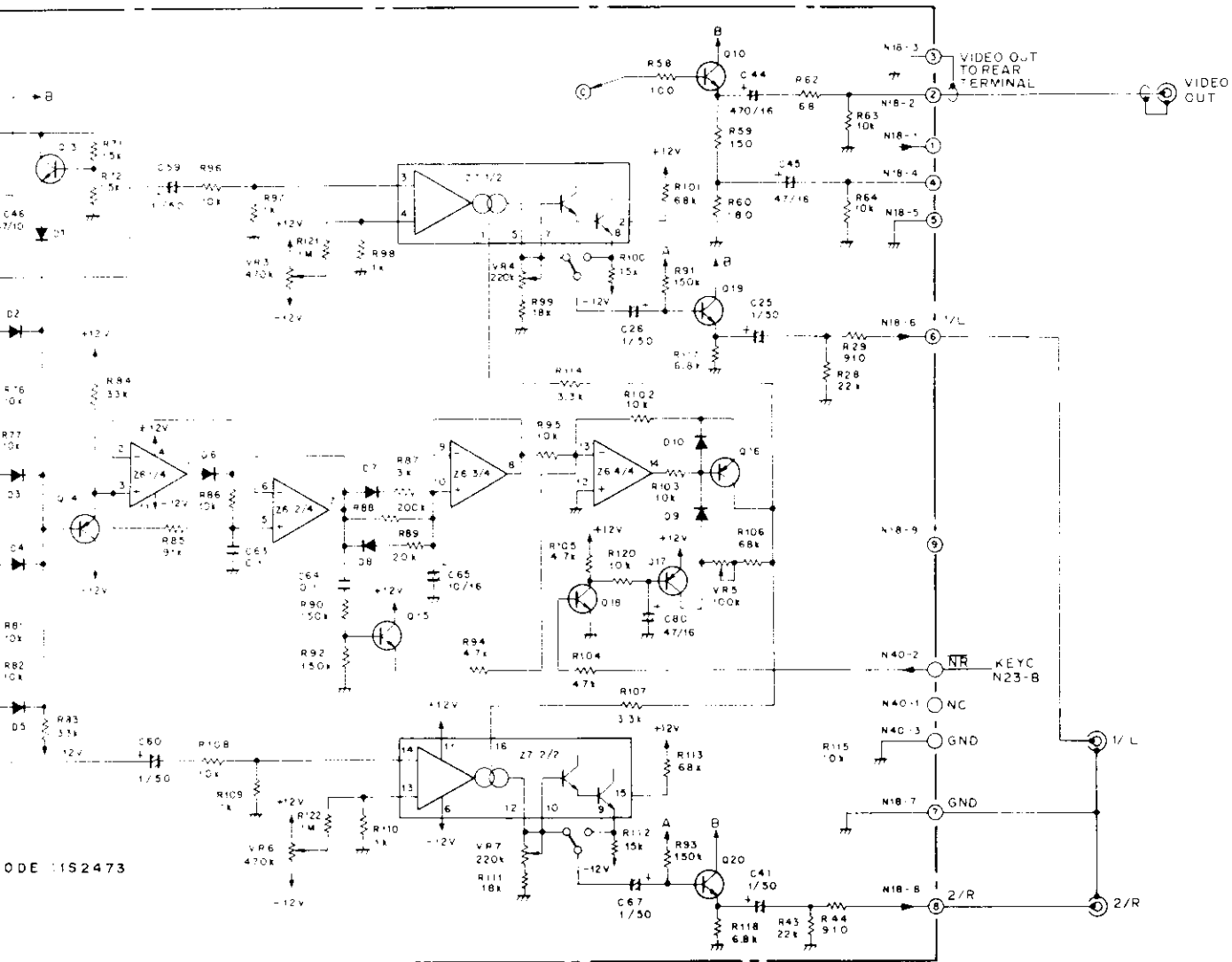

A

B

C

ODE 1S2473

TC4016BP

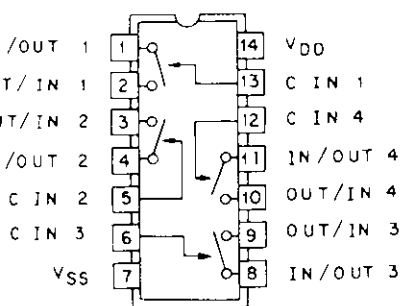

PA3001A

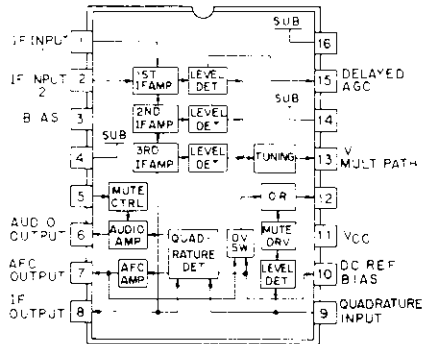

μPC4558C
NJM4558D

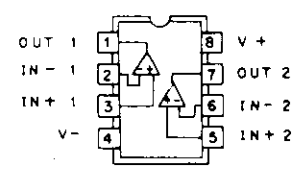

D

AUDX(VWV-044) Parts list

1

(MK)(Part No.) (IT)(REF Nos. & DESCRIPTIONS)

PA3001A	Z	1, 2	
TC4016BP	Z	3	
UPC4558C (NJM4558D)	Z	4	
TL074CN (LF347N)	Z	5, 6	
LM13600J (LM13600N) (LM13700N)	Z	7	
2SC1815-Y/GR	Q	1, 3, 10	
2SC1815-O/Y/GR	Q	4, 5, 7- 9, 11- 13, 15, 18- 20	
(2SC2320-E/F) (2SC2603-E/F) 2SA1015-O/Y/GR	Q	14, 16, 17	
1S2473	D	1- 10, 13, 14	
RD1/4PM000J	R	1- 4, 6, 7, 9, 12- 15, 17- 22, 28, 29, 32- 35, 37- 46, 49, 50, 53- 60, 62- 65, 67, 71-114, 117, 118, 120-125	
VCP-025	VR	1, 2	2.2k
VCP-032	VR	3, 6	470k
VCP-031	VR	4, 7	220k
VCP-030	VR	5	100k
CKDYF103Z50	C	2, 8, 10- 17, 27- 31, 33, 49, 52, 54, 56, 69, 81	
CCDCH020J50	C	2	
CKDYB102K50	C	3, 57, 58, 82, 84	
CEA4R7M25	C	9, 66	
CEA101M6R3	C	18, 34, 50	
CCDSL431J50	C	19	
CQMA152J50	C	20, 36	
CKDYB601K50	C	21, 37	
CEA010M50	C	22, 25, 26, 38, 41, 59, 60, 67, 70, 71	
CQMA472J50	C	23, 39	
CQMA272J50	C	24, 40	
CCDSL331J50	C	35	
CKDYB152K50	C	42, 43	
CEA471M16	C	44	
CEA470M16	C	45- 47, 68, 80, 83	
CEA101M16	C	51, 53, 55	
CQMA682J50	C	61, 62	
CQMA104J50	C	63, 64	
VCH-011	C	65	
VTL-048 (VTL-068)	L	1, 2	62uH
VTL-024 (VTL-062)	L	3- 5	12uH
VTL-023 (VTL-061)	L	6	10uH
VTF-006 (VTF-021)	VL	1, 2	18uH
VTF-017 (VTF-023)	F	1	2.3M B.P.F
VTF-018 (VTF-024)	F	2	2.8M B.P.F

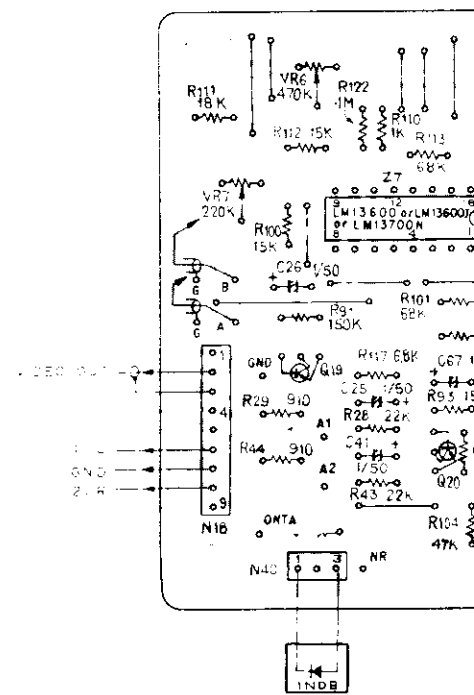
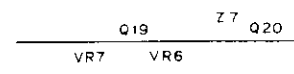

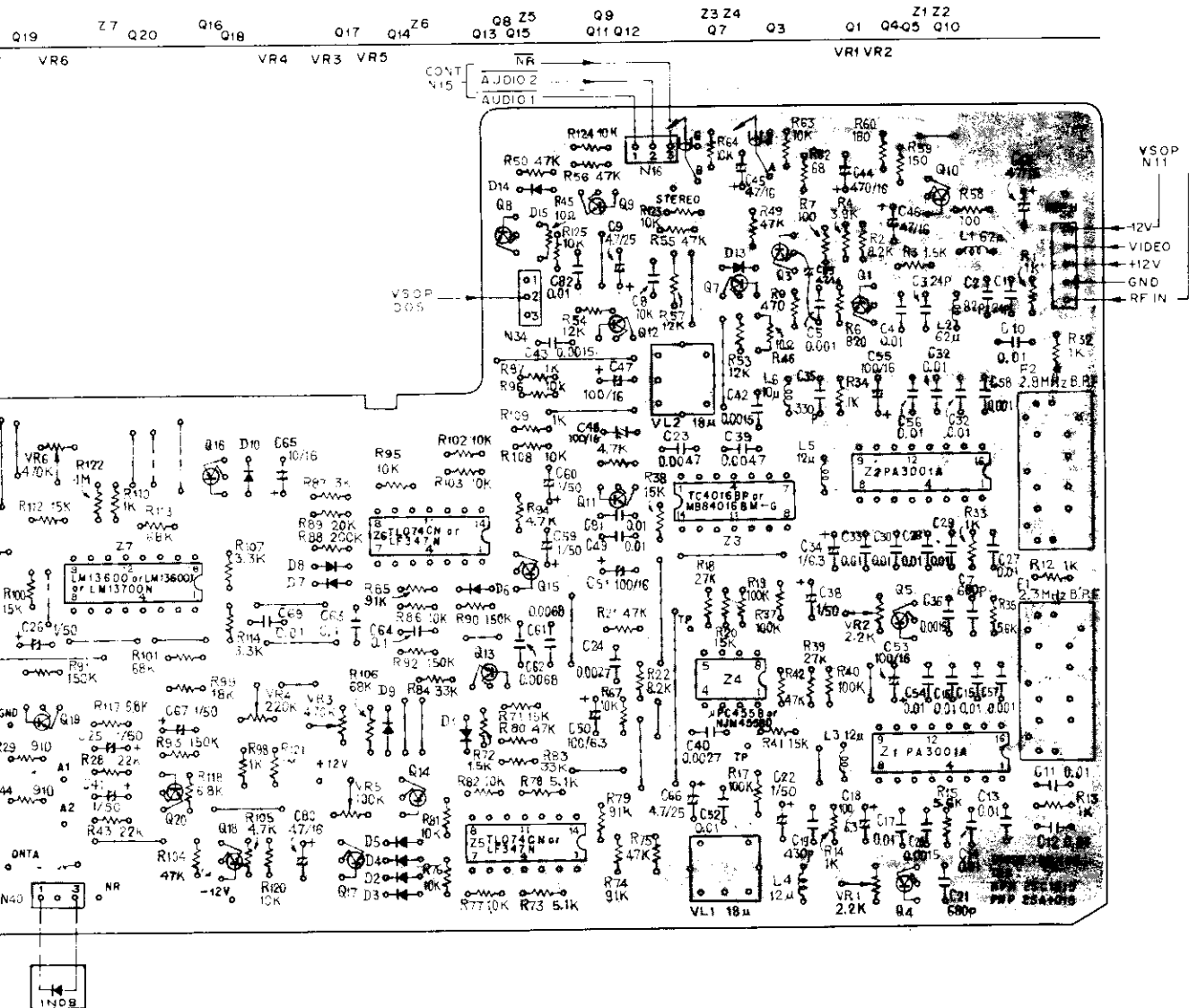

11-6 CONT, GATB AND IOIB

A

B

C

D

CONT (VWG-102)

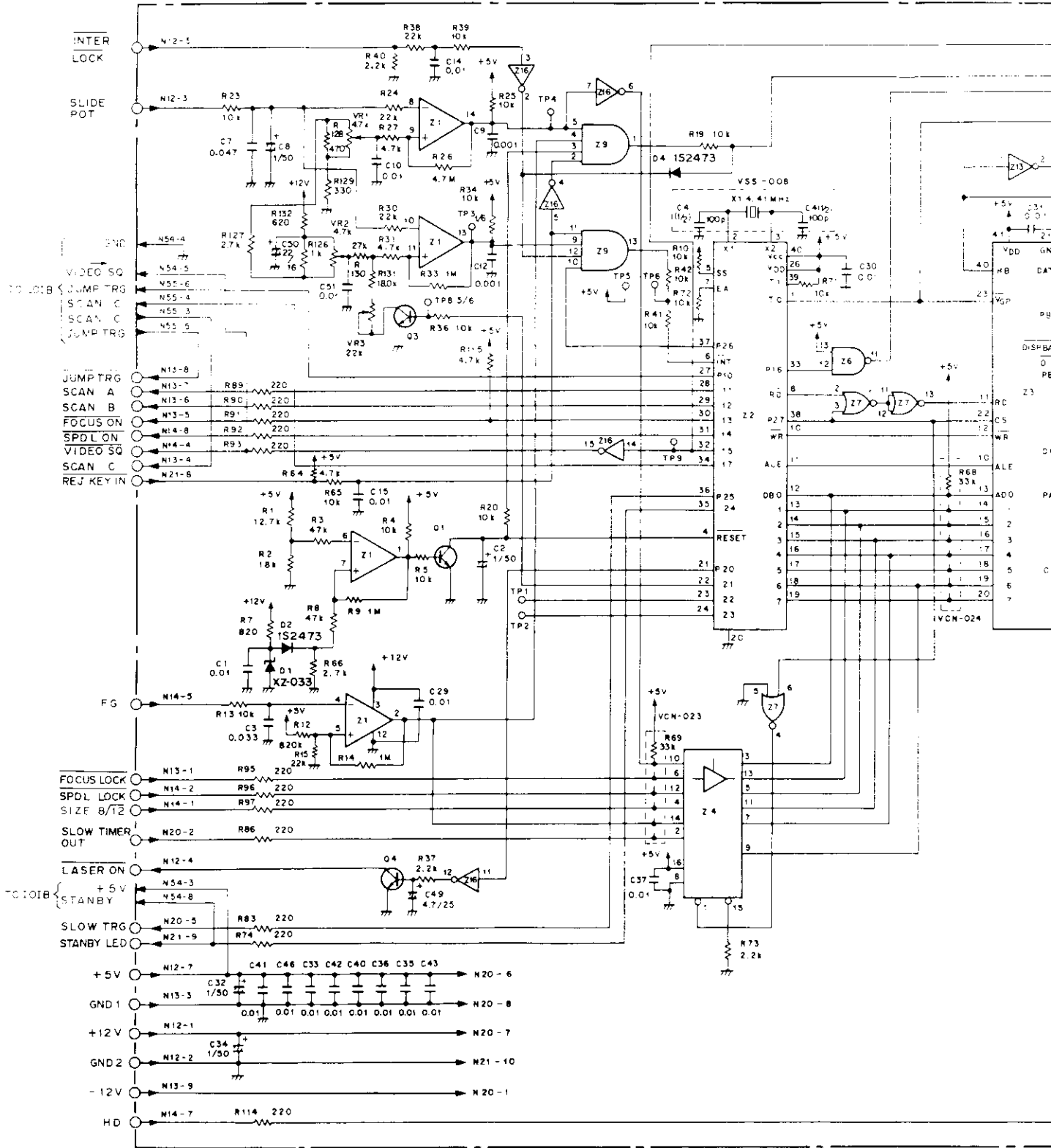

GATB (VWG-044)

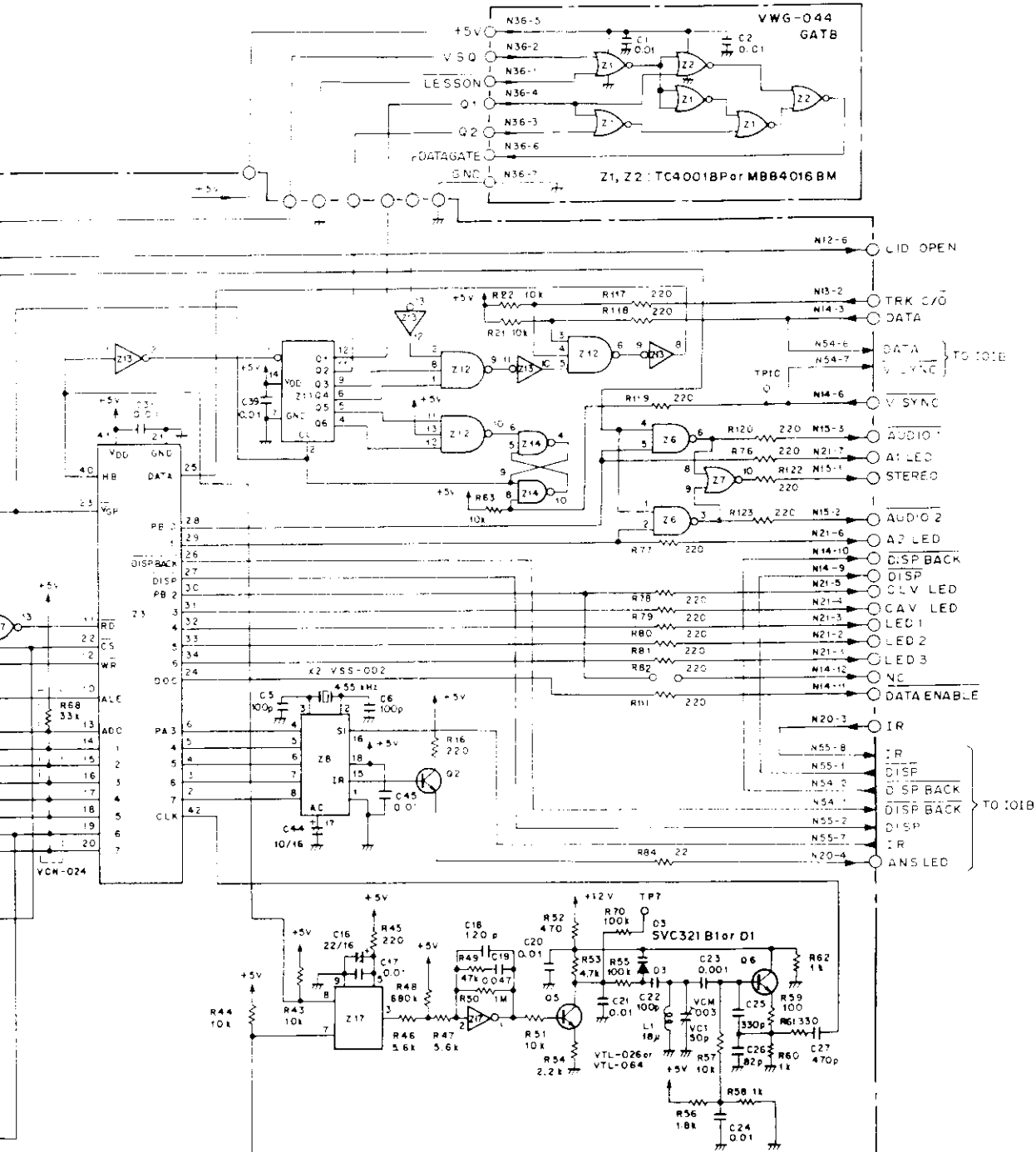

A

B

C

D

VWG-102

- | | | | | | |
|----|---|-----|---------------------------|--------|--------------------------|
| Z1 | μPC339C | Z8 | M50117CP | Z16 | TC4049BP or
MBB4049BM |
| Z2 | UD6005A | Z9 | TC4082BP or
MBB4082BM | Z17 | TC5081P or
TC5081AP |
| Z3 | UD4001A | Z11 | TC4024BP or
MBB4024BM | TR | Q3 |
| Z4 | SN74LS365AN or
HD74LS365AP | Z12 | TC4023BP or
MBB4023BM | | 25C1815Y |
| Z6 | SN74LS00N or
HD74LS00P | Z13 | TC4069UBP or
MBB4069BM | OTHERS | 25C1815Y, O, GR |
| Z7 | SN74LS02N or
TC40H002P or
HD74LS02P | Z14 | TC4011BP or
MBB4011BM | D1 | XZ-033 |
| | | | | D2, D4 | 15S133T-77 |
| | | | | O3 | SVC321B1 or D1 |

1

2

Z2 Z3 Z4 Z8 Z17 Z14 Z9 Z16 Z7 Z1 Z6 Z11-Z13
Q6 Q5 Q2 Q3 Q4 Q1

VR3 VR2 VR1

A

A

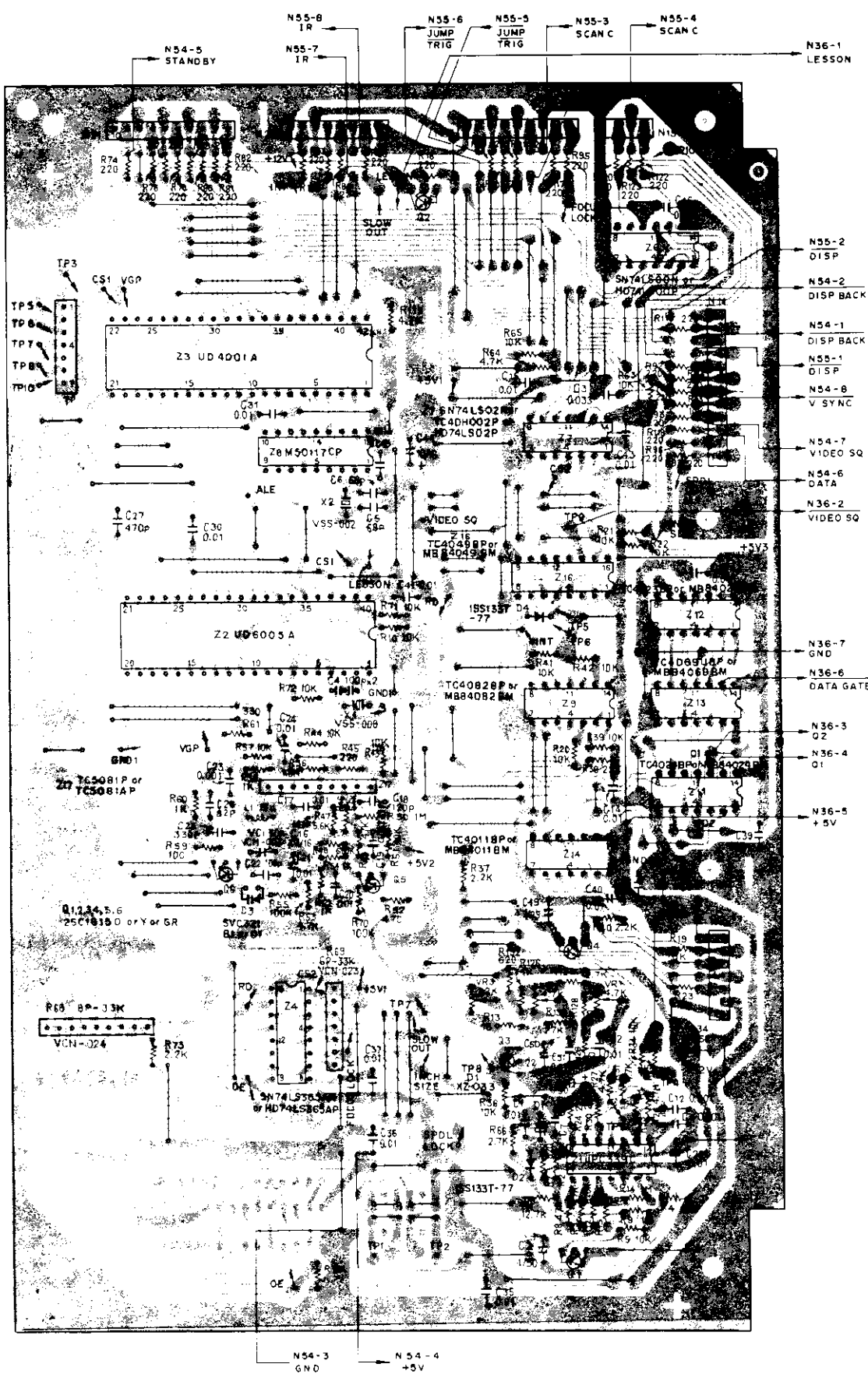

B

B

C

C

D

D

1

2

3

CONT(VWG-102) Parts list

1

(MK)(Part No.) (IT)(REF Nos. & DESCRIPTIONS)

UPC339C	Z	1	
UD6005A	Z	2	
UD4001	Z	3	
SN74LS365AN	Z	4	
(HD74LS365AP)			
SN74LS00N	Z	6	
(HD74LS00P)			
SN74LS02N	Z	7	
(TC40H002P)			
(HD74LS02P)			
MS0117CP	Z	8	
TC4002BP	Z	9	
(MB84002BM)			
TC4024BP	Z	11	
(MB84024BM)			
TC4023BP	Z	12	
(MB84023BM)			
TC4069UBP	Z	13	
(MB84069BM)			
TC4011BP	Z	14	
(MB84011BM)			
TC4049BP	Z	16	
(MB84049BM)			
TC5081P	Z	17	
(TC5081AP)			
2SC1815-0/Y/GR	Q	1-	6
(2SC1740-Q/R)R			
XZ-033	D	1	
(RD3.3EB1)			
1S2473	D	2,	4
SVC321SP-B1/D1	D	3	
RN1/4PR0000F	R	1, 2,131	
RD1/4PM000J	R	3- 5, 7- 10, 12- 16, 19- 27, 30, 31, 33, 34, 36- 66, 70- 74, 76- 84, 86, 89- 93, 95- 97,111,114,115,117-120, 122,123,126-130,132	
VCN-024	R	68	33k Array
VCN-023	R	69	33k Array
VCP-026	VR	1, 2	4.7k
VCP-028	VR	3	22k
CKDYF103Z50	C	1, 14, 15, 17, 20, 21, 24, 29- 31, 33, 35- 37, 39- 43, 45, 46, 51, 52	
CEA010M50	C	2, 8, 32, 34	
CKDYF333Z50	C	3	
CCDSL101J50	C	5, 6, 22	
CQMA473K50	C	7, 19	
CKDYB102K50	C	9, 12, 23	
CEA220M16	C	16, 50	
CCDSL121J50	C	18	
CKDYB331K50	C	25	
CCDSL820J50	C	26	
CKDYB471K50	C	27	
CEA100M16	C	44	
CEA4R7M25	C	49	
VCM-003	VC	1	50PF
VTL-026	L	1	18uH
(VTL-064)			
VSS-008	X	1	4.41MHz
VSS-002	X	2	455kHz

GATB(VWG-044) Parts list

1

(MK)(Part No.) (IT)(REF Nos. & DESCRIPTIONS)

TC40018P	Z	1, 2	
(MB840018M)			
CKDYF103Z50	C	1, 2	

1

2

3

A

B

C

D

IOIB (VWG-101)

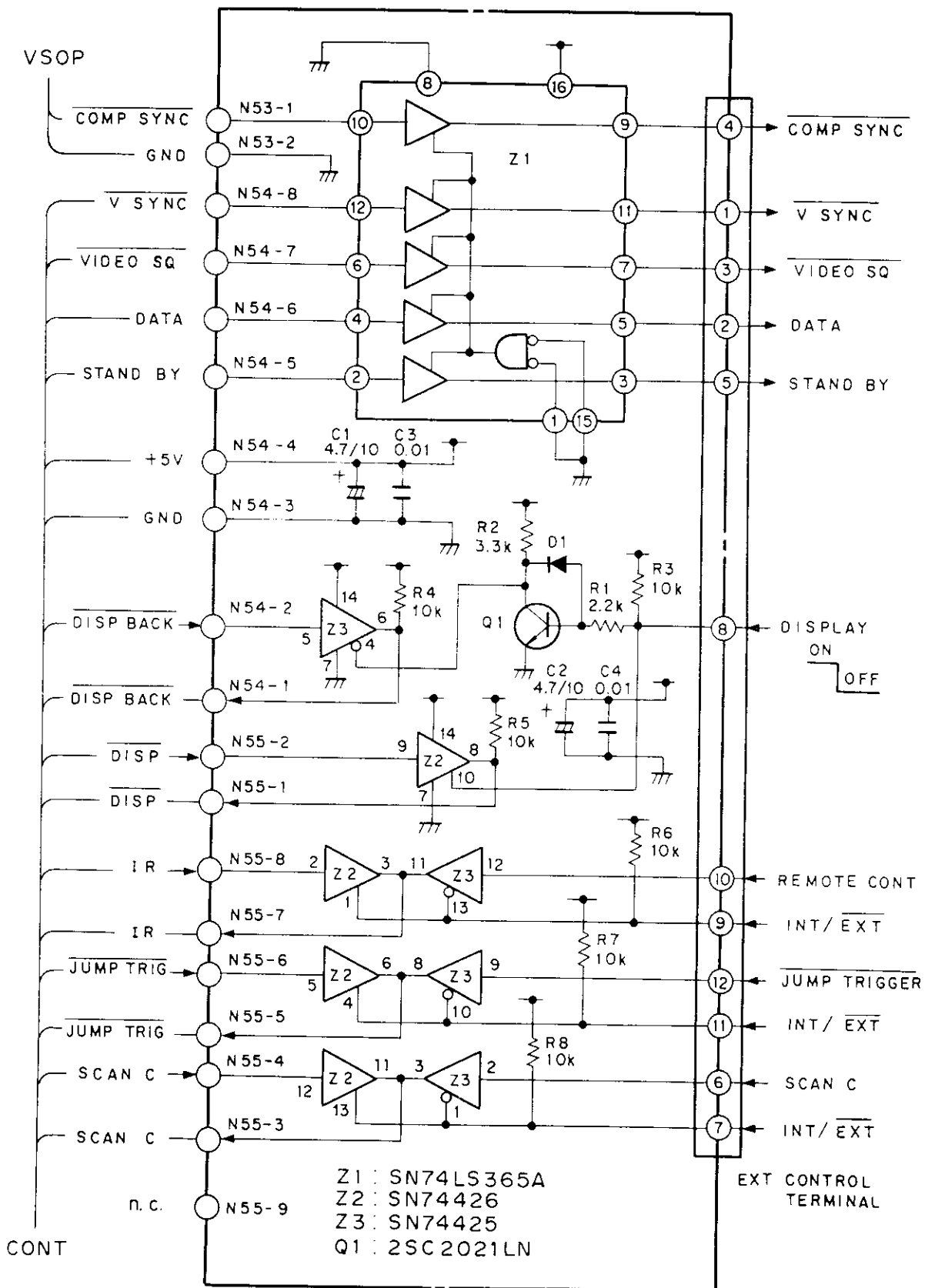

1

2

3

IOIB(VWG-101) Parts list

1

(MK)(Part No.) (IT)(REF Nos. & DESCRIPTIONS)

SN74LS365AN Z 1
 (HD74LS365AP)
 SN74426 Z 2
 SN74425 Z 3

2SC2021LN-R Q 1

1S2473 D 1

RD1/4PM000J R 1- 8

CEA4R7M35LL C 1, 2
 CKDYF103Z50 C 3, 4

VKN-133 Control terminal

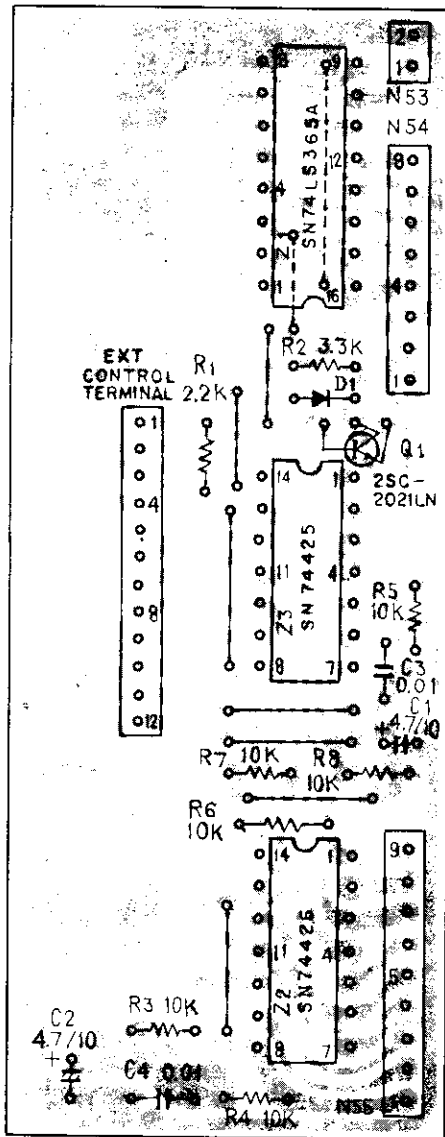

P SYNC

YNC

EO SQ

A

ND BY

LAY
 OFF

OTE CONT

/ EXT

P TRIGGER

/ EXT

N C

EXT

TROL
 MINAL

11-7 KEYC AND IRAB

A

B

C

D

KEYC (VWW-046)

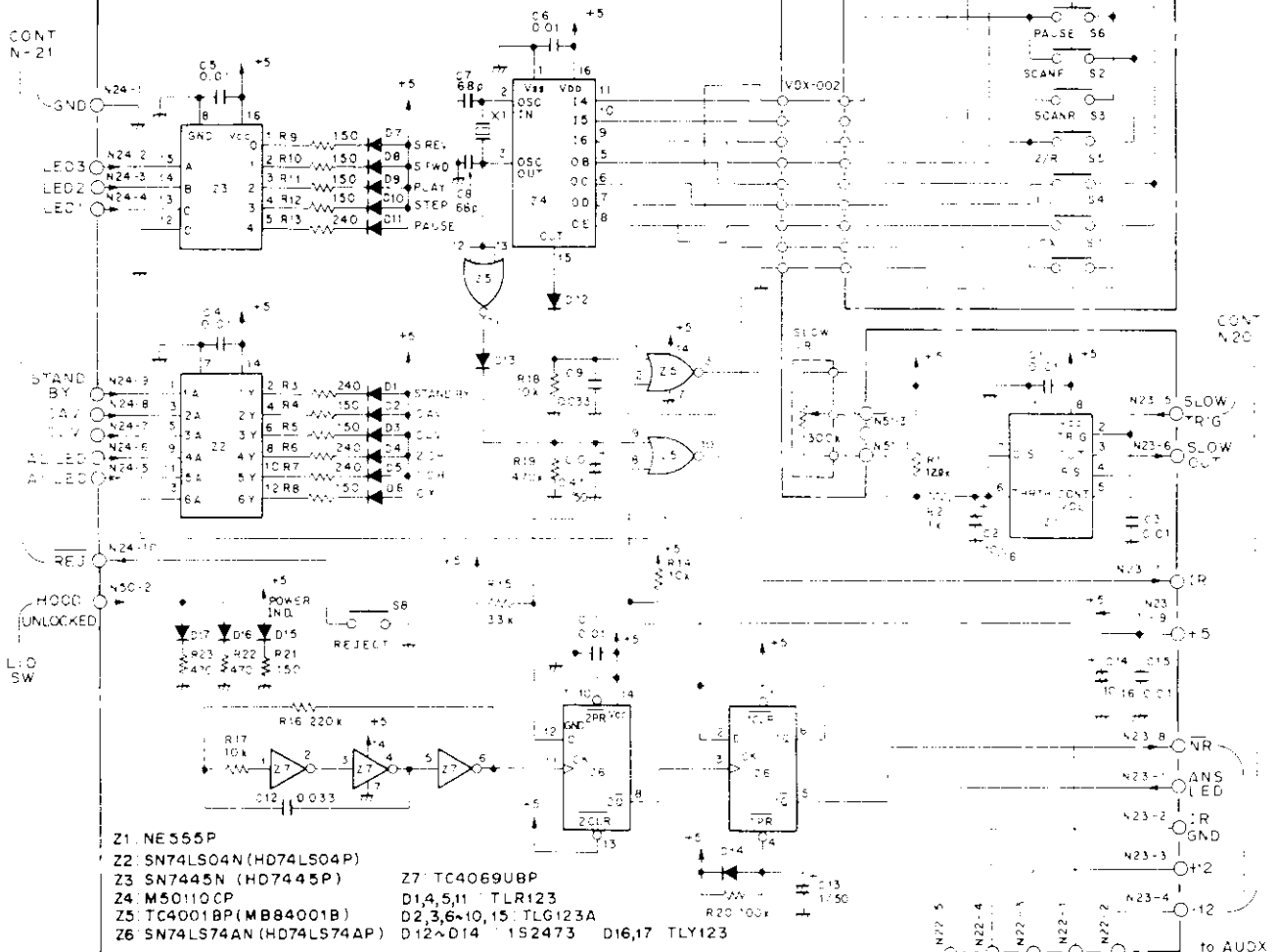

- Z1. NE555P
- Z2. SN74LS04N (HD74LS04P)
- Z3. SN7445N (HD7445P)
- Z4. M50110CP
- Z5. TC4001BP (MB84001B)
- Z6. SN74LS74AN (HD74LS74AP)
- Z7. TC4069UBP
- D1,4,5,11. TLR123
- D2,3,6-10,15. TLG123A
- D12~D14. 1S2473
- D16,17. TLY123

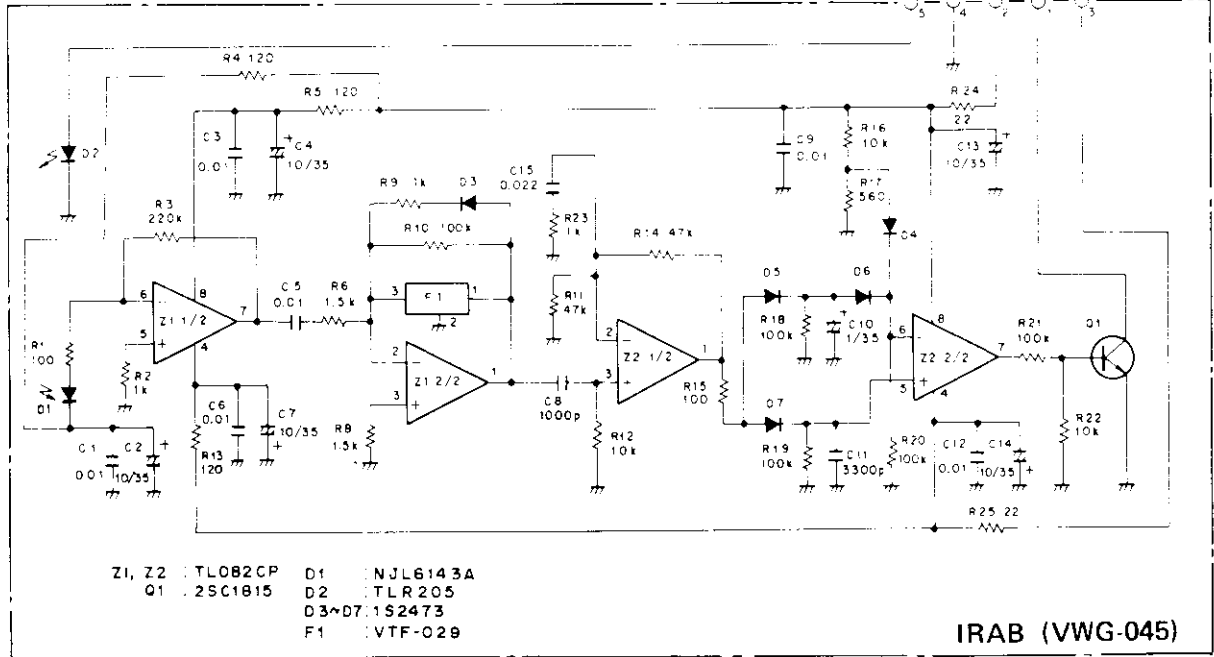

- Z1, Z2. TL082CP
- Q1. 2SC1815
- D1. NJL6143A
- D2. TLR205
- D3~D7. 1S2473
- F1. VTF-029

IRAB (VWG-045)

EYC(VW-046) Parts list

1

(MK)(Part No.) (IT)(REF Nos. & DESCRIPTIONS)

NE555P	Z	1	
SN74LS04N	Z	2	
(HD74LS04P)			
SN7445N	Z	3	
(HD7445P)			
M50110CP	Z	4	
TC4001BP	Z	5	
(MB84001BM)			
SN74LS74AN	Z	6	
(HD74LS74AP)			
TC4069UBP	Z	7	
(MB84069BM)			
TLR123	D	1, 4, 5, 11	
TLG123A	D	2, 3, 6, 10, 15	
1S2473	D	12, 14	
FLY123	D	16, 17	
RD1/4PM000J	R	1- 23	
CKDYF103Z50	C	1, 3- 6, 11, 15	
VCR-011	C	2	10/16
CCDSL101J50	C	7, 8	
CKDYF333Z50	C	9	
CEAR47M50LL	C	10	
CQMA333J50	C	12	
CEA010M50LL	C	13	
CEA100M16LL	C	14	
VSS-002	X	1	455KHz
VSC-004	SW	1- 8	
VDX-002			Flat harness
VNL-089			LED Holder 2
VNL-090			LED Holder 3
VNL-091			LED Holder 5

IRAB(VW-045) Parts list

1

(MK)(Part No.) (IT)(REF Nos. & DESCRIPTIONS)

TL082CP	Z	1, 2	
2SC1815-0/Y/GR	Q	1	
NJL6143A	D	1	
TLR123	D	2	
1S2473	D	3- 7	
RD1/4PM000J	R	1- 6, 8- 25	
CKDYF103Z50	C	1, 3, 5, 6, 9, 12	
CEA100M35LL	C	2, 4, 7, 13, 14	
CKDYB102K50	C	8, 16	
CEA2R2M50LL	C	10	
CQMA332K50	C	11	
CQMA153K50	C	15	
VTF-035	F	1	38kHz Notch
(VTF-029)			
VKP-113			Conn.cords
VEC-081			Sub filter

A

B

C

D

A

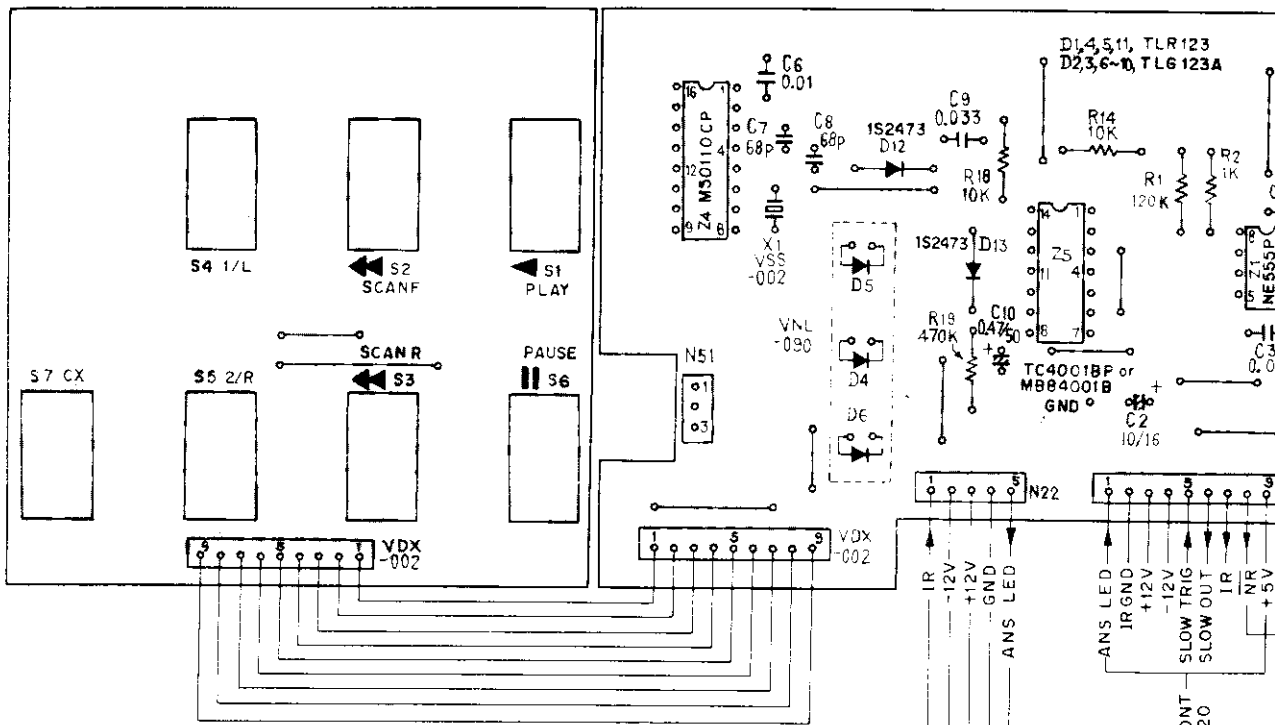

B

C

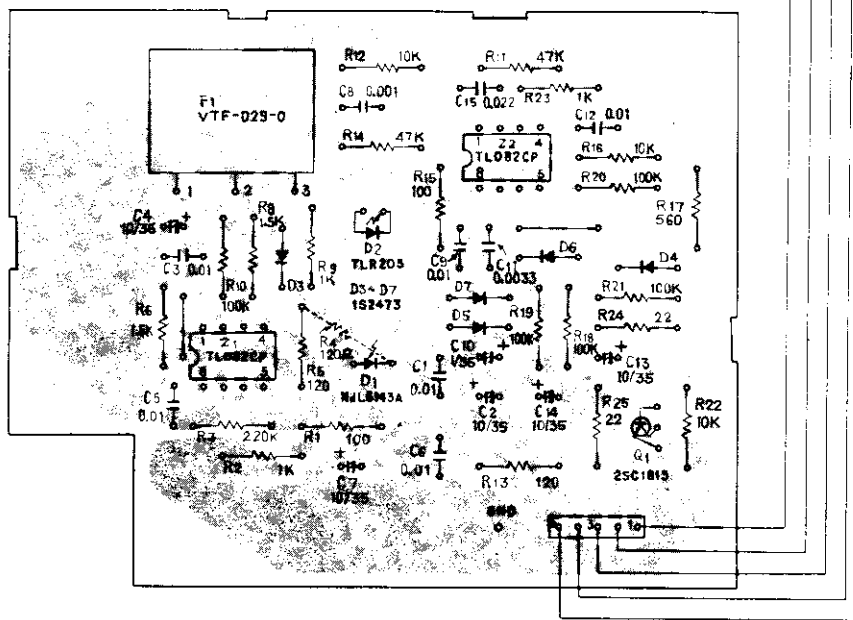

D

VR2

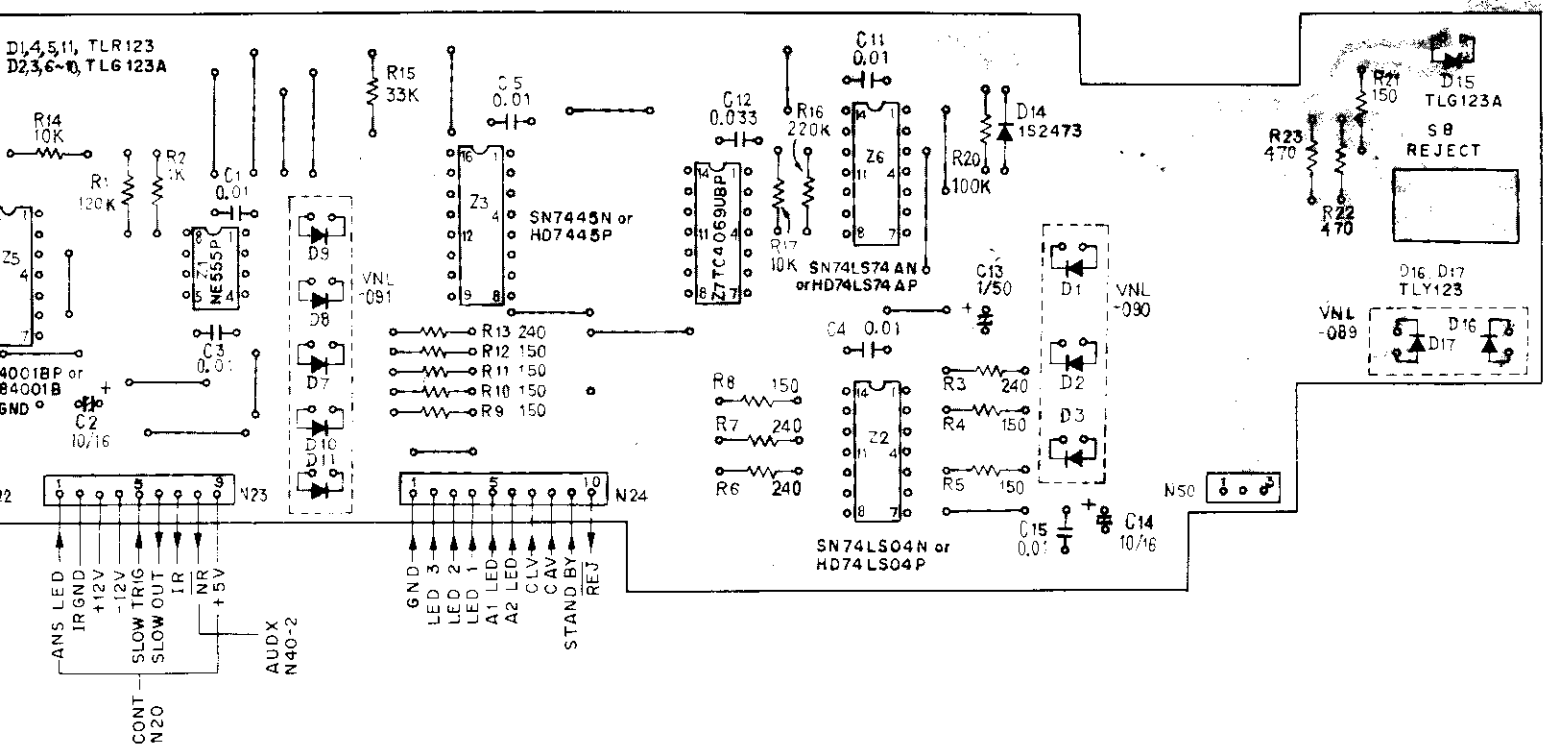

NE555P

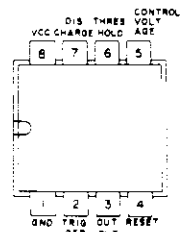

TC4001BP MB84001BP

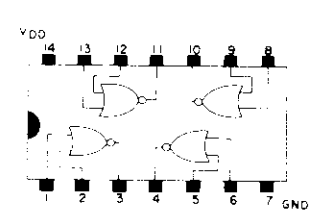

M50110CP

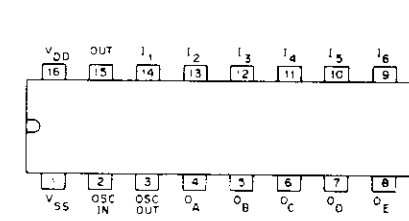

HD74LS04P SN74LS04N

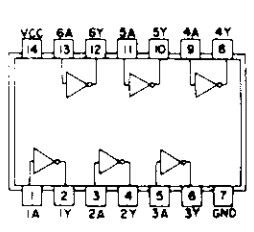

TL082CP

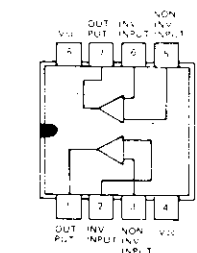

HD7445P

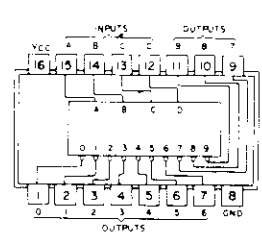

2SA1015 2SC1815



HD74LS74P SN74LS74N

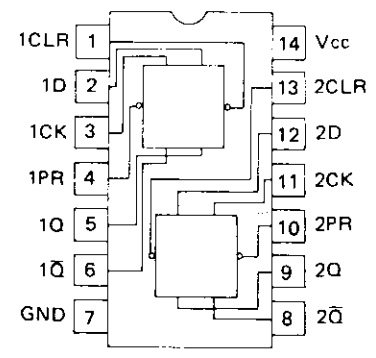

12. EXPLODED VIEWS AND PARTS LIST

12-1 EXTERNAL AND TOP VIEW



A

B

C

D

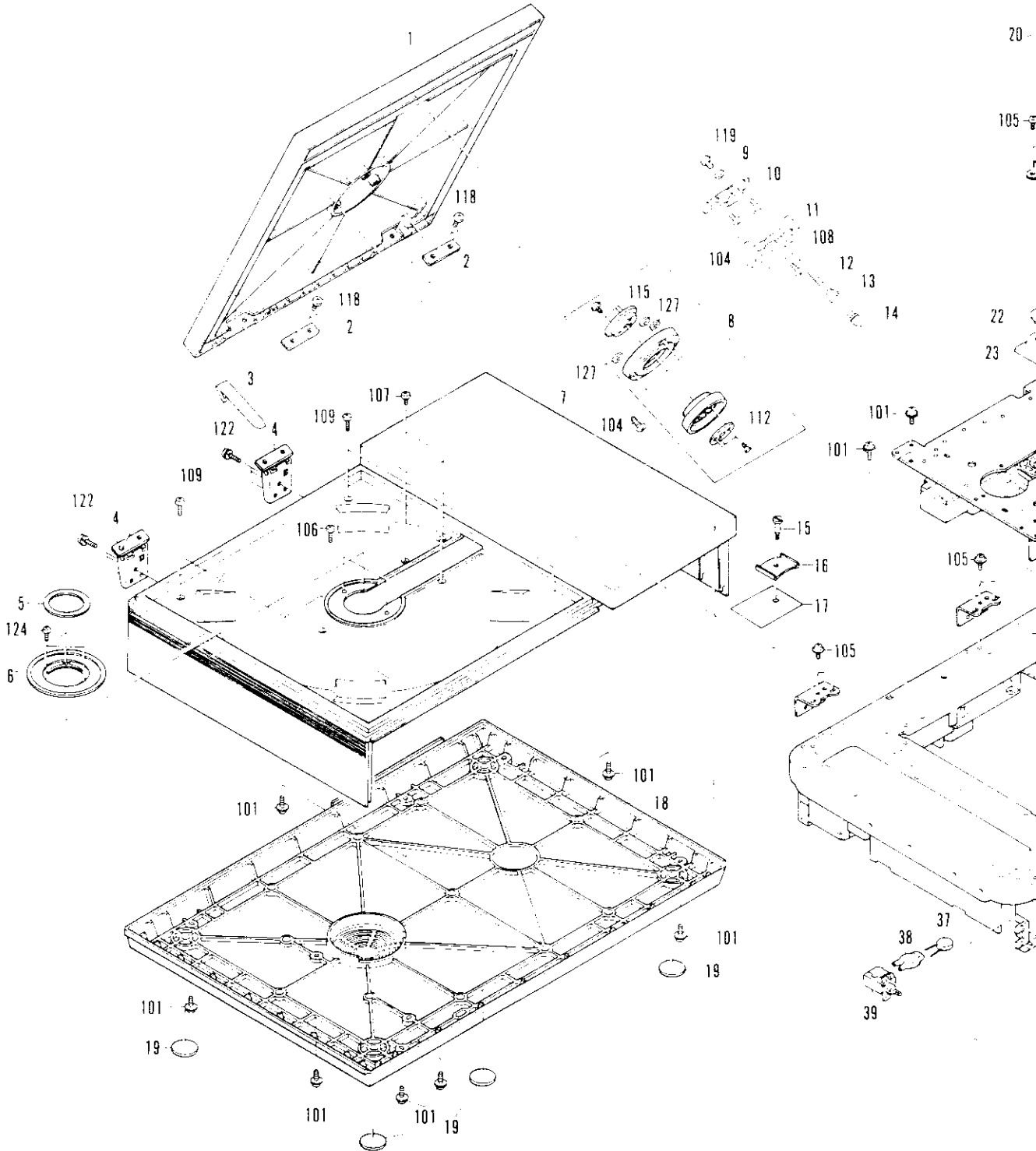

4

5

6

A

B

C

D

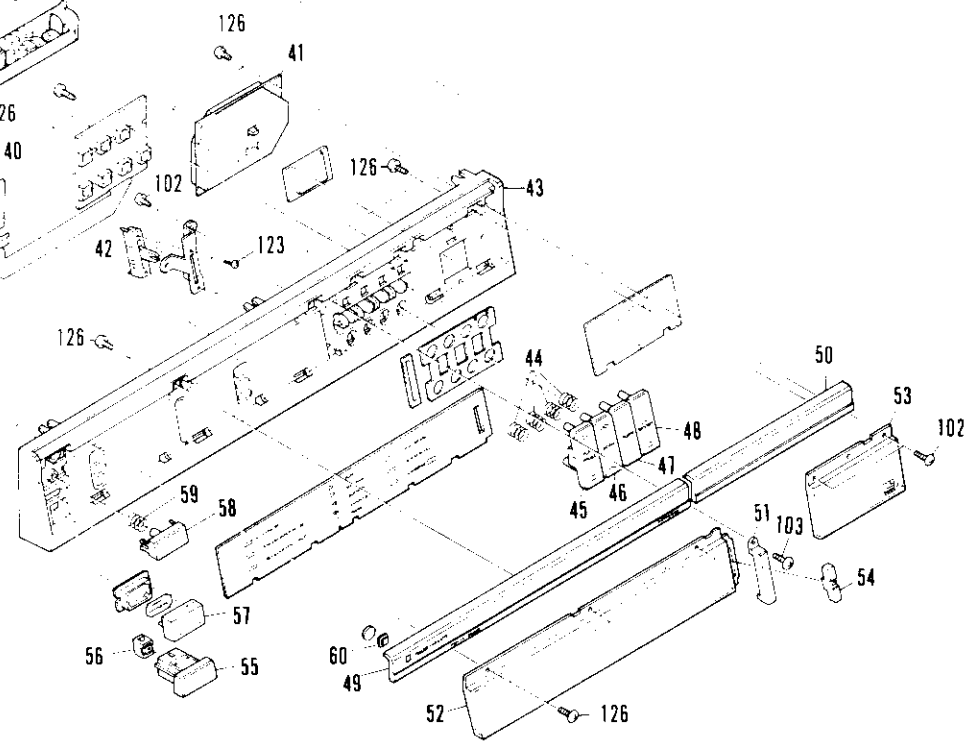
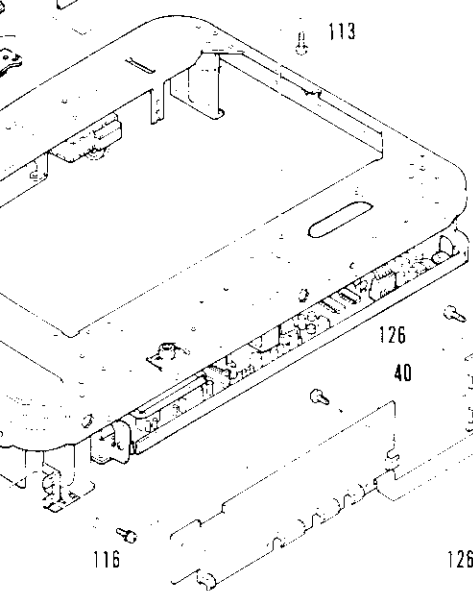
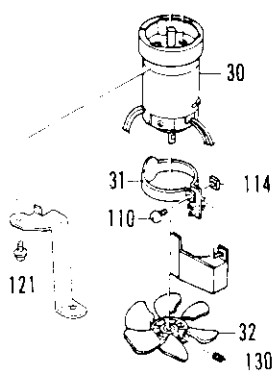
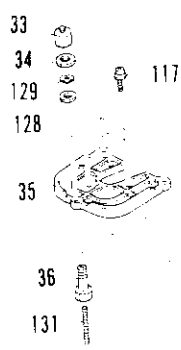
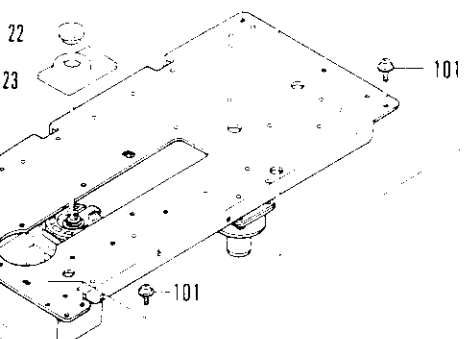
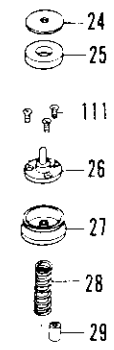
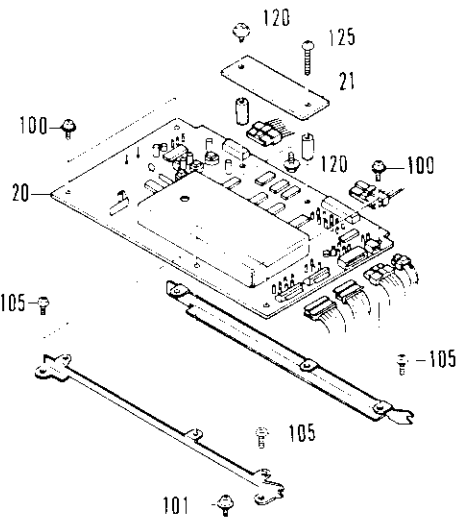

4

5

6

TOP VIEW PARTS LIST

No.	Parts no.	Parts name	No.	Parts no.	Parts name
1.	VXX-063	Hood assembly	51.	VNK-068	Volume cover
2.	VNE-244	Plate	52.	VNK-063	Acryl cover
3.	VNE-286	Hood lever	53.	VNK-064	Acryl cover
4.	VXA-053	Hood hinge	54.	VNL-088	Volume knob
5.	VNL-077	Turntable ring	55.	VAC-079	Power button
6.	VNG-004	Turntable	56.	VEC-070	Flexible ring
7.	---	Top housing	57.	VNK-062	Acryl cover
8.	VXX-041	Disc clamper	58.	VAC-080	Reject key top
9.	VEB-038	Washer	59.	VBH-051	Key spring
10.	VNE-305	Interlock base	60.	VNK-067	Window
11.	VNL-092	Protector			
12.	VBH-059	Spring			
13.	VNL-022	Collar			
14.	VLA-060	Interlockpin			
15.	VLL-089	Shipping screw			
16.	VNE-276	Shipping plate	100.	ACZ 30P060	FMC
17.	VRW-118	Caution tag	101.	AMZ 30P080	FMC
18.	VNK-077	Bottom cover	102.	BBZ 30P060	FMC
19.	VED-008	Cushion	103.	BBZ 30P060	FZK
20.	VWG-102	Cont	104.	BBZ 30P080	FZK
21.	VWG-044	GATB	105.	BCZ 30P050	FMC
22.	VHA-012	Lens cap	106.	BMZ 26P050	FMC
23.	VNH-027	Focus motor cover	107.	BMZ 30P040	FZK
24.	VEC-062	Yoke seal	108.	BMZ 30P060	FZK
25.	VMX-001	Clamper magnet	109.	BMZ 30P080	FZK
26.	VXA-062	Yoke assembly	110.	BMZ 40P120	FMC
27.	VNV-003	Centering hab	111.	CMZ 26P060	FMC
28.	VBH-034	Spring	112.	CMZ 26P080	FZK
29.	VLP-005	Spacer ring	113.	IPZ 30P080	FMC
30.	VXM-017	Spindle motor	114.	NZ 40	FMC
31.	---	Capacitor assembly	115.	PMA 26P060	FMC
32.	VNM-001	Fin	116.	PMA 30P060	FMC
33.	---	Holding bolt	117.	PMA 30P080	FMC
34.	---	Nut	118.	PMA 40P120	FZK
35.	---	Motor holder	119.	PMB 26P060	FMC
36.	---	Adjustment bolt	120.	PMB 30P060	FMC
37.	VCG-011	Capacitor	121.	PMB 30P080	FMC
38.	VEC-063	Capacitor cover	122.	PMB 30P100	FZK
39.	VSA-006	Power switch	123.	PMZ 20P030	FMC
40.	VWW-046	KEYC	124.	PMZ 26P060	FMC
41.	VWG-045	IRAB	125.	VCZ 30P200	FMC
42.	VCS-010	Slide volume	126.	VPZ 30P060	FMC
43.	VNK-061	Front panel	127.	WA 30F080	N100
44.	VBH-058	Key spring	128.	WB 50	FMC
45.	VAC-081	Play key top	129.	WW 50	FBT
46.	VAC-082	Scan key top	130.	ZMD 30H040	FBT
47.	VAC-083	Audio key top	131.	ZND 30H250	FBT
48.	VAC-084	CX key top	132.		
49.	VNK-065	Front acryl(L)	133.		
50.	VNK-133	Front acryl(R)	134.		

BOTTOM VIEW PARTS LIST

No.	Parts no.	Parts name	No.	Parts no.
1.	VCS-005	Potentiometer	101.	ACZ 30P060 FMC
2.	VXA-059	Gear assembly	102.	AMZ 30P080 FMC
3.	VBH-042	Spring	103.	BCZ 30P050 FMC
4.	VNL-045	Pinion	104.	BCZ 30P050 FZK
5.	VNL-031	Retainer	105.	BMZ 30P060 FZK
6.	VNL-034	Roller	106.	BPZ 30P080 FZK
7.	VXX-006	Retainer pinion ass'y	107.	IMZ 20P100 FMC
8.	VNG-002	Rail	108.	PMA 30P050 FMC
9.	VDG-016	Power cord	109.	PMA 30P060 FMC
10.	VEC-027	Cord stopper	110.	PMA 30P120 FMC
11.	VKN-007	BNC jack	111.	PMA 30P120 FRD
12.	VKB-003	2P pin jack	112.	PMA 30P120 FZK
13.	VWG-101	IDIB	113.	PMA 40P060 FMC
14.	VWM-001	MCNB	114.	PMB 30P060 FMC
15.	---	Mech. chassis	115.	PMB 30P080 FGN
16.	VXM-008	Slider motor	116.	PMB 30P080 FMC
17.	VXA-054	Slider motor holder	117.	PMB 40P080 FMC
18.	VBH-041	Spring	118.	VCZ 30P080 FMC
19.	VNL-028	Pinion	119.	VCZ 30P100 FMC
20.	VWR-011	LSPS	120.	WA 17D035 D025
21.	VNH-023	High voltage cover	121.	WC 50 FMC
22.	VWS-022	VSOP	122.	YE 20 FUC
23.	VWV-023	CPCB	123.	YE 30 FUC
24.	VSF-007	Switch	124.	ZMD 30H060 FBT
25.	VBH-040	Switch spring	125.	ZMK 40H080 FBT
26.	VKC-005	4P terminal		
27.	VTT-016	Power transformer		
28.	VWR-019	SYPS		
29.	VWG-043	PSCB		
30.	VXP-005	Plunger		
31.	VSF-006	Switch		
32.	VBH-045	Spring		
33.	VBH-043	Spring		
34.	VXX-039	Inter lock pin guide assembly		
35.	VEB-031	Slider cushion		
36.	VWV-044	AUDX		
37.	VGX-023	Slider assembly		

12-2 BOTTOM VIEW

1

2

3

A

B

C

D

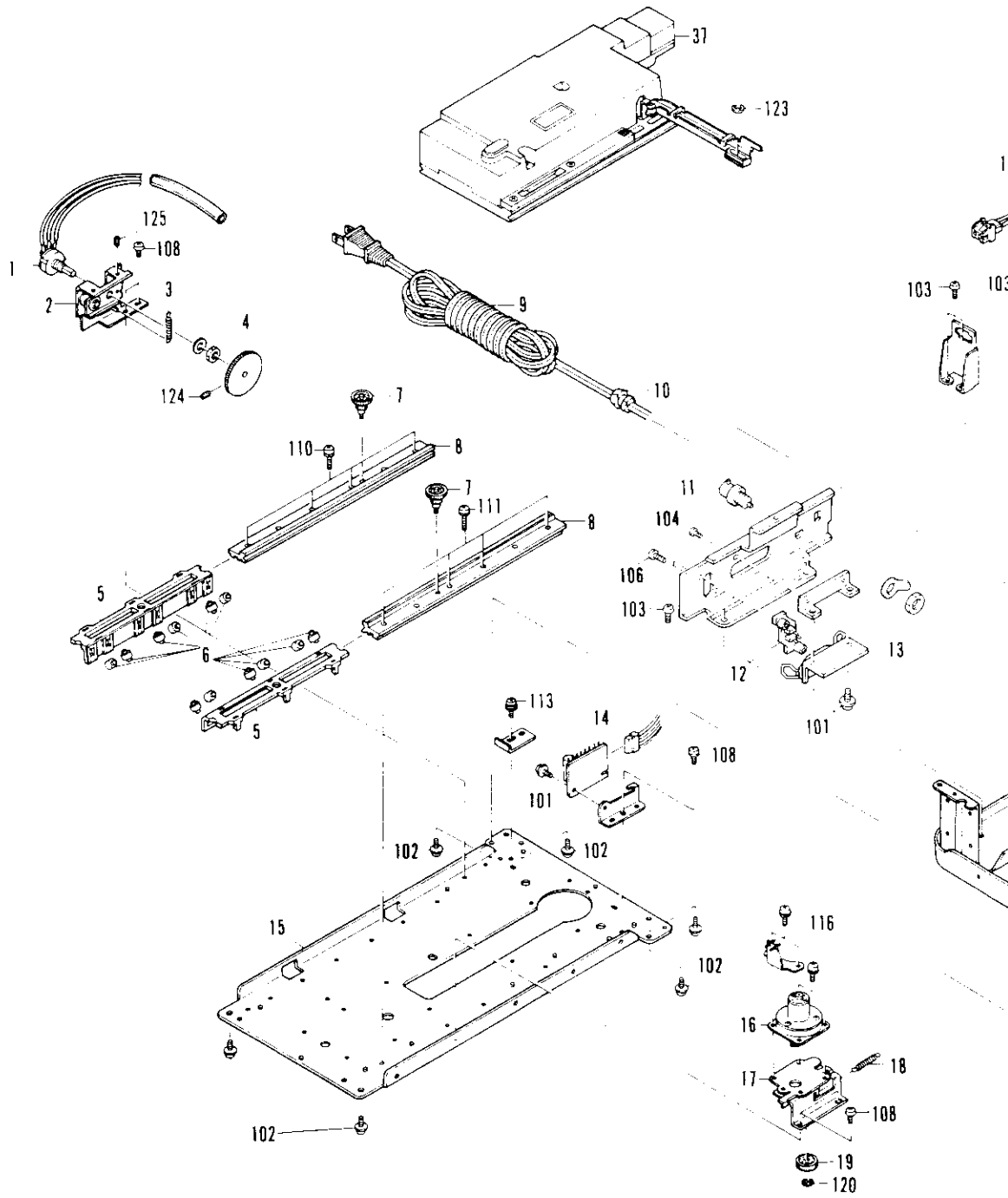

1

2

3

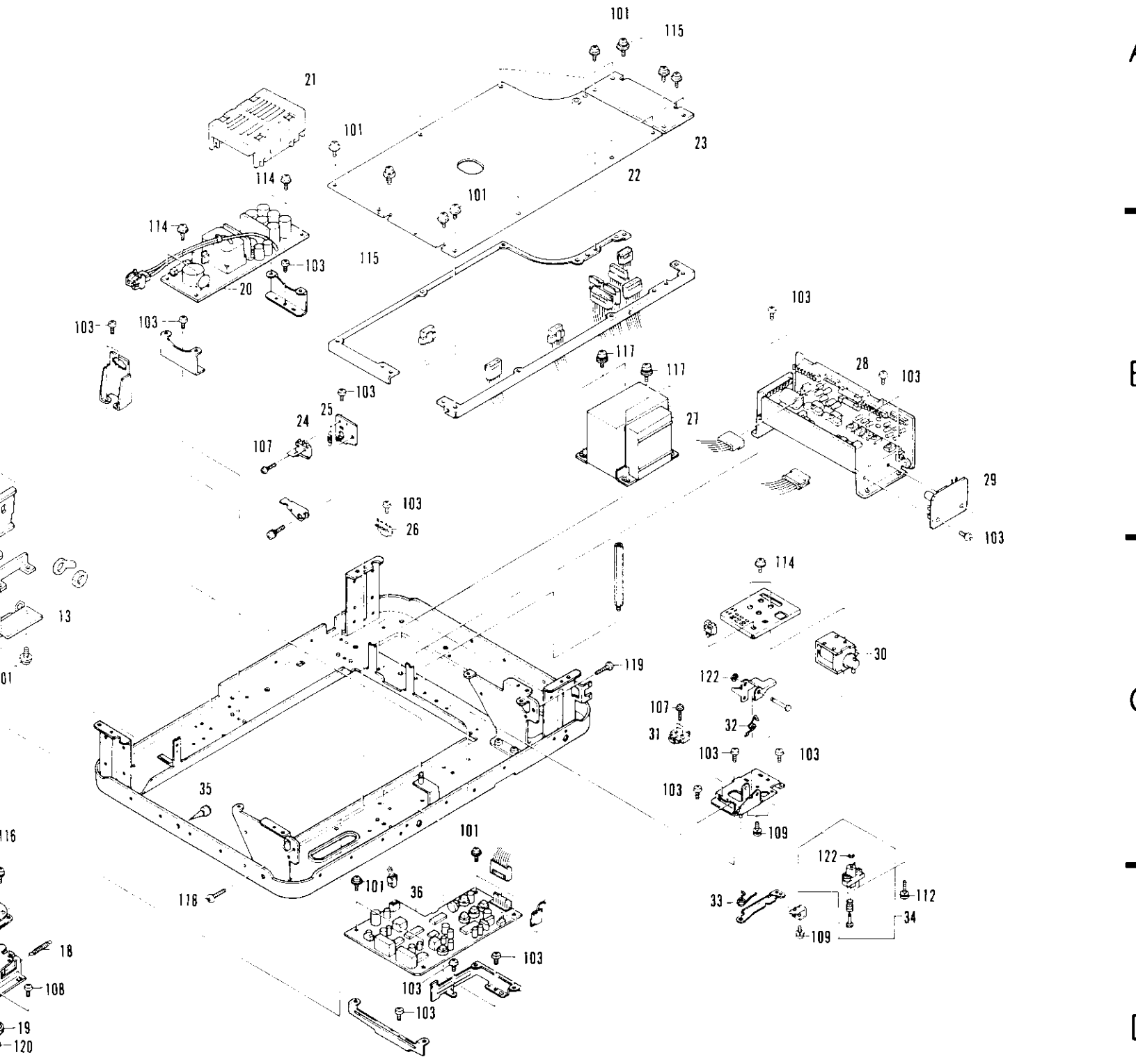

12-3 SLIDER VIEW

A

B

C

D

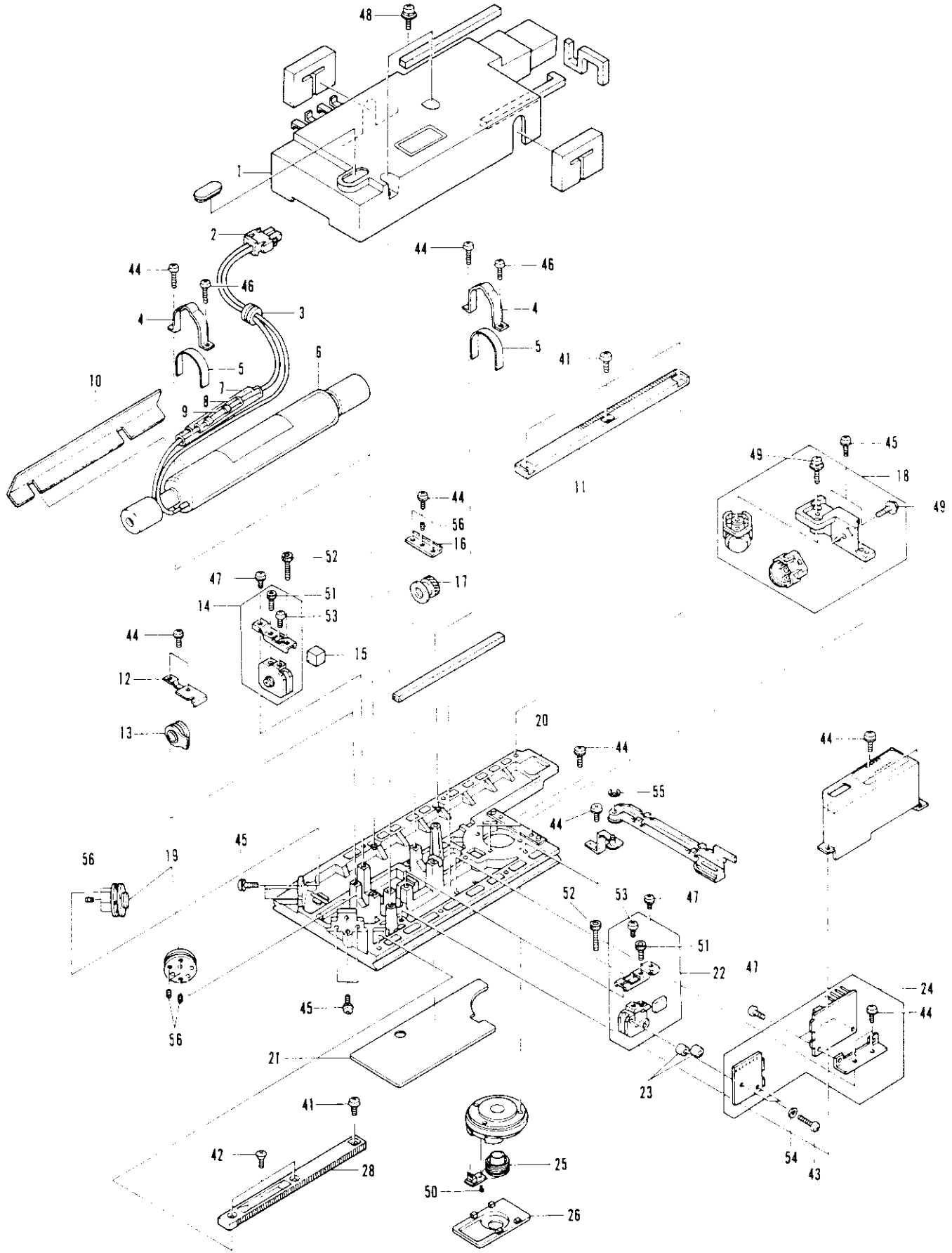

SLIDER PARTS LIST

No.	Parts no.	Parts name	No.	Parts no.
1.	—	Dust cover	41.	BMZ 30P060 FMC
2.	VDA-013	H.V. cord assembly	42.	CMZ 30P080 FBT
3.	VEB-032	Bushing	43.	PMA 26P100 FMC
4.	VNE-212	Tube holder	44.	PMA 30P060 FMC
5.	VED-014	Tube cushion	45.	PMA 30P080 FMC
6.	VGN-004 (VGN-005)	Laser tube	46.	PMA 30P100 FMC
7.	VXX-021	Vinyl tube	47.	PMB 30P060 FMC
8.	VDM-001	Insulator pipe	48.	PMB 30P080 FMC
9.	VCN-014	Resistor (47kohms/2W)	49.	PMB 30P100 FMC
10.	—	Radiation shield	50.	PMZ 20P040 FMC
11.	VNL-044	Rack(G)	51.	SMK 30H080 FBT
12.	VNE-261	Grating holder	52.	SMK 30H120 FBT
13.	VGX-022	Grating assembly	53.	VCZ 30P060 FMC
14.	VGX-018	DG lens assembly	54.	WA 26N050 W050
15.	—	Prism	55.	YE 30 FUC
16.	VNE-148	Wave plate holder	56.	ZMR 30H080 FBT
17.	VGX-016	Wave plate assembly		
18.	VGX-024	Servo mirror assembly		
19.	VGX-015	Fixed mirror assembly		
20.	—	Slider base		
21.	VEC-051	Mask plate		
22.	VGX-020	Photo-detector assembly		
23.	VLP-003	Photo-detector spacer		
24.	VWV-010	RFAM		
25.	VGX-025	Objective assembly		
26.	VNH-027	Focus motor cover		
27.	VHA-012	Lens cap		
28.	VNL-029	Rack(N)		

A

B

C

D

13. SAFETY INFORMATION

1. SAFETY PRECAUTIONS

The following check should be performed for the continued protection of the customer and service technician.

LEAKAGE CURRENT CHECK

Measure leakage current to a known earth ground (water pipe, conduit, etc.) by connecting a leakage current tester such as Simpson Model 229-2 or equivalent between the earth ground and all exposed metal parts of the appliance (input/output terminals, screwheads, metal overlays, control shaft, etc.). Plug the AC line cord of the appliance directly into a 120V AC 60Hz outlet and turn the AC power switch on. Any current measured must not exceed 0.5mA.

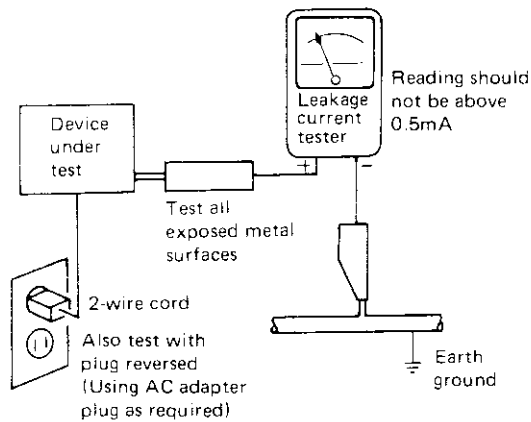

AC Leakage Test

ANY MEASUREMENTS NOT WITHIN THE LIMITS OUTLINED ABOVE ARE INDICATIVE OF A POTENTIAL SHOCK HAZARD AND MUST BE CORRECTED BEFORE RETURNING THE APPLIANCE TO THE CUSTOMER.

2. PRODUCT SAFETY NOTICE

Many electrical and mechanical parts in the appliance have special safety related characteristics. These are often not evident from visual inspection nor the protection afforded by them necessarily can be obtained by using replacement components rated for voltage, wattage, etc. Replacement parts which have these special safety characteristics are identified in this Service Manual.

Electrical components having such features are identified by marking with a  on the schematics and on the parts list in this Service Manual.

The use of a substitute replacement component which does not have the same safety characteristics as the PIONEER recommended replacement one, shown in the parts list in this Service Manual, may create shock, fire, or other hazards.

Product Safety is continuously under review and new instructions are issued from time to time. For the latest information, always consult the current PIONEER Service Manual. A subscription to, or additional copies of, PIONEER Service Manual may be obtained at a nominal charge from PIONEER.

14. PACKING PROCESS

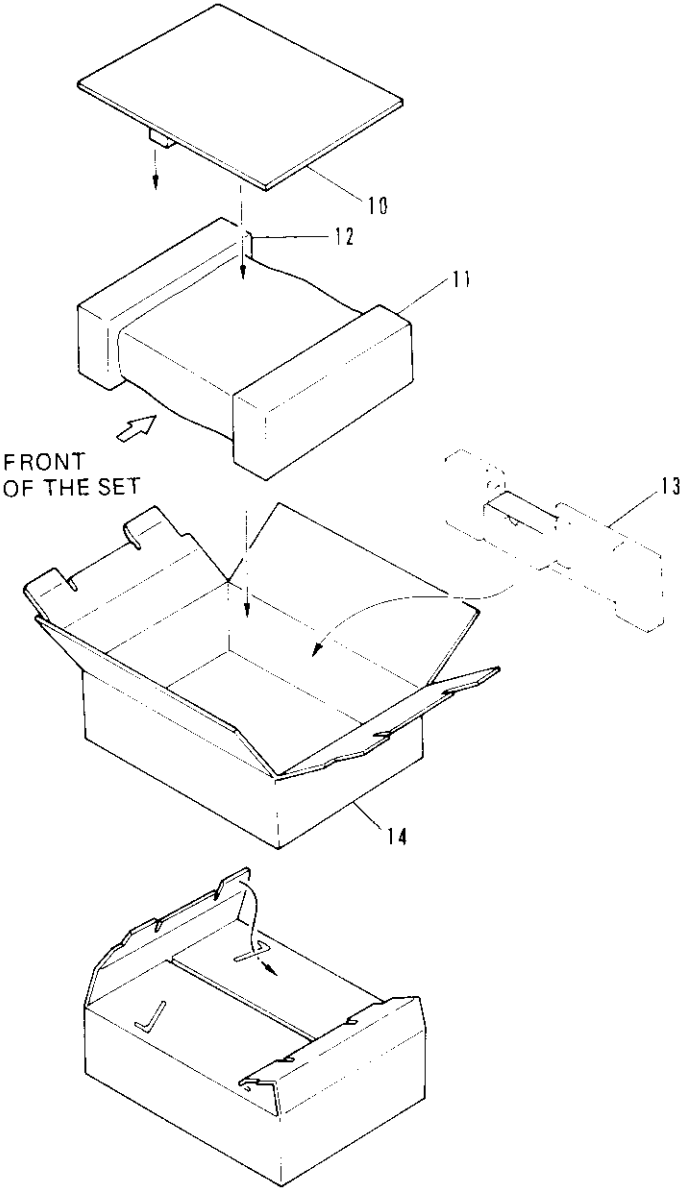
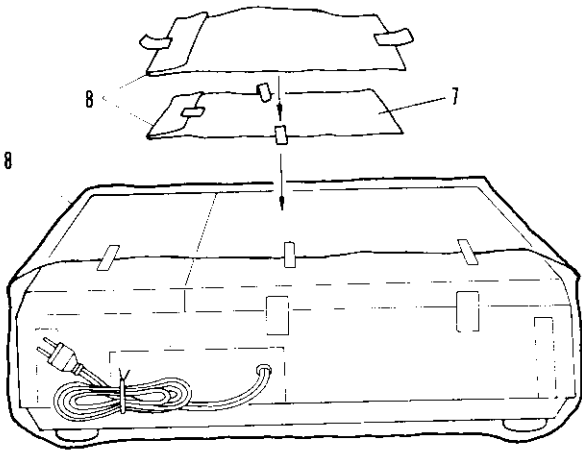
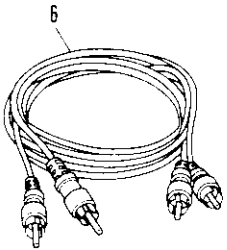
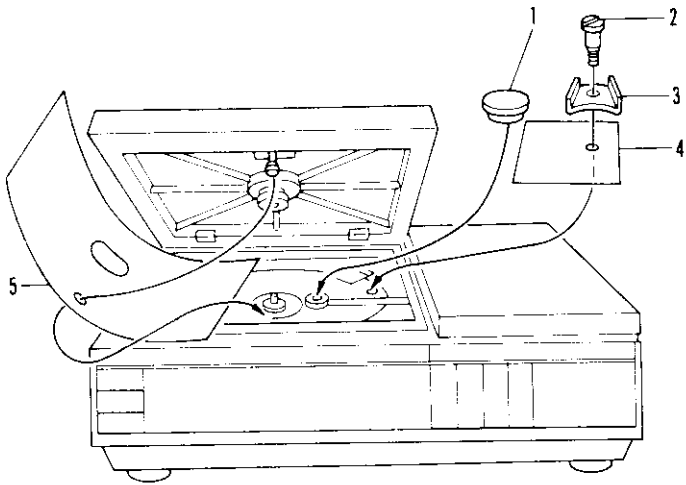

PACKING PROCESS

1. Set the lens cap, loose the shipping screw together with the caution tag and the shipping plate, and then close the hood securely. Power switch must be turned off.
2. Bind the power cord, place the set in the bag and seal it with adhesive tapes as illustrated. Take care that the power plug doesn't hurt the set.
3. Stick the bag containing "Operating Instructions" and the bag containing Audio cords on the packed set.
4. Fit the pad L and R correctly into position at the both ends of the set, place the set in the packing box and insert the holder behind the set and set the cushion board on the set with the cushion against the front of the hood.
5. As illustrated, turn the top of the box in.

Parts List

Mark	No.	Part No.	Description
	1.	VHA-012	Lens cap
	2.	VLL-089	Shipping screw
	3.	VNE-276	Shipping plate
	4.	VRW-118	Caution tag
	5.	VHA-017	Sheet
	6.	VDE-010	Audio connecting cords
	7.	VRB-023	Operating Instructions
	8.	VHL-014	Bag
	9.	VHA-029	Bag
	10.	VXA-069	Cushion board
	11.	VHA-031	Pad R
	12.	VHA-030	Pad L
	13.	VHX-003	Holder
	14.	VHG-069	Packing box